

436-431 MECHANICS 4
UNIT 2
MECHANICAL VIBRATION

J.M. KRODKIEWSKI

2008

THE UNIVERSITY OF MELBOURNE
Department of Mechanical and Manufacturing Engineering

MECHANICAL VIBRATIONS

Copyright © 2008 by J.M. Krodkiewski

The University of Melbourne
Department of Mechanical and Manufacturing Engineering

CONTENTS

0.1	INTRODUCTION.	5
I	MODELLING AND ANALYSIS	7
1	MECHANICAL VIBRATION OF ONE-DEGREE-OF-FREEDOM LINEAR SYSTEMS	9
1.1	MODELLING OF ONE-DEGREE-OF-FREEDOM SYSTEM	9
1.1.1	Physical model	9
1.1.2	Mathematical model	12
1.1.3	Problems	16
1.2	ANALYSIS OF ONE-DEGREE-OF-FREEDOM SYSTEM	28
1.2.1	Free vibration	28
1.2.2	Forced vibration	34
1.2.3	Problems	44
2	MECHANICAL VIBRATION OF MULTI-DEGREE-OF-FREEDOM LINEAR SYSTEMS	66
2.1	MODELLING	66
2.1.1	Physical model	66
2.1.2	Mathematical model	67
2.1.3	Problems	74
2.2	ANALYSIS OF MULTI-DEGREE-OF-FREEDOM SYSTEM	93
2.2.1	General case	93
2.2.2	Modal analysis - case of small damping	102
2.2.3	Kinetic and potential energy functions - Dissipation function	109
2.2.4	Problems	112
2.3	ENGINEERING APPLICATIONS	151
2.3.1	Balancing of rotors	151
2.3.2	Dynamic absorber of vibrations	157
3	VIBRATION OF CONTINUOUS SYSTEMS	162
3.1	MODELLING OF CONTINUOUS SYSTEMS	162
3.1.1	Modelling of strings, rods and shafts	162
3.1.2	Modelling of beams	166

3.2	ANALYSIS OF CONTINUOUS SYSTEMS	168
3.2.1	Free vibration of strings, rods and shafts	168
3.2.2	Free vibrations of beams	174
3.2.3	Problems	182
3.3	DISCRETE MODEL OF THE FREE-FREE BEAMS	214
3.3.1	Rigid Elements Method.	214
3.3.2	Finite Elements Method.	217
3.4	BOUNDARY CONDITIONS	225
3.5	CONDENSATION OF THE DISCREET SYSTEMS	226
3.5.1	Condensation of the inertia matrix.	227
3.5.2	Condensation of the damping matrix.	228
3.5.3	Condensation of the stiffness matrix.	228
3.5.4	Condensation of the external forces.	228
3.6	PROBLEMS	229

II EXPERIMENTAL INVESTIGATION 237

4	MODAL ANALYSIS OF A SYSTEM WITH 3 DEGREES OF FREE-DOM	238
4.1	DESCRIPTION OF THE LABORATORY INSTALLATION	238
4.2	MODELLING OF THE OBJECT	239
4.2.1	Physical model	239
4.2.2	Mathematical model	240
4.3	ANALYSIS OF THE MATHEMATICAL MODEL	241
4.3.1	Natural frequencies and natural modes of the undamped system.	241
4.3.2	Equations of motion in terms of the normal coordinates - transfer functions	241
4.3.3	Extraction of the natural frequencies and the natural modes from the transfer functions	242
4.4	EXPERIMENTAL INVESTIGATION	243
4.4.1	Acquiring of the physical model initial parameters	243
4.4.2	Measurements of the transfer functions	244
4.4.3	Identification of the physical model parameters	245
4.5	WORKSHEET	246

0.1 INTRODUCTION.

The purpose of this text is to provide the students with the theoretical background and engineering applications of the theory of vibrations of mechanical systems. It is divided into two parts. Part one, **Modelling and Analysis**, is devoted to this solution of these engineering problems that can be approximated by means of the linear models. The second part, **Experimental Investigation**, describes the laboratory work recommended for this course.

Part one consists of four chapters.

The first chapter, **Mechanical Vibration of One-Degree-Of-Freedom Linear System**, illustrates modelling and analysis of these engineering problems that can be approximated by means of the one degree of freedom system. Information included in this chapter, as a part of the second year subject Mechanics 1, where already conveyed to the students and are not to be lectured during this course. However, since this knowledge is essential for a proper understanding of the following material, students should study it in their own time.

Chapter two is devoted to modeling and analysis of these mechanical systems that can be approximated by means of the **Multi-Degree-Of-Freedom** models. The Newton's-Euler's approach, Lagrange's equations and the influence coefficients method are utilized for the purpose of creation of the mathematical model. The considerations are limited to the linear system only. In the general case of damping the process of looking for the natural frequencies and the system forced response is provided. Application of the modal analysis to the case of the small structural damping results in solution of the initial problem and the forced response. Dynamic balancing of the rotating elements and the passive control of vibrations by means of the dynamic absorber of vibrations illustrate application of the theory presented to the engineering problems.

Chapter three, **Vibration of Continuous Systems**, is concerned with the problems of vibration associated with one-dimensional continuous systems such as string, rods, shafts, and beams. The natural frequencies and the natural modes are used for the exact solutions of the free and forced vibrations. This chapter forms a base for development of discretization methods presented in the next chapter

In chapter four, **Approximation of the Continuous Systems by Discrete Models**, two the most important, for engineering applications, methods of approximation of the continuous systems by the discrete models are presented. *The Rigid Element Method* and the *Final Element Method* are explained and utilized to produce the inertia and stiffness matrices of the free-free beam. Employment of these matrices to the solution of the engineering problems is demonstrated on a number of examples. The presented condensation techniques allow to keep size of the discrete mathematical model on a reasonably low level.

Each chapter is supplied with several engineering problems. Solution to some of them are provided. Solution to the other problems should be produced by students during tutorials and in their own time.

Part two gives the theoretical background and description of the laboratory experiments. One of them is devoted to the experimental determination of the natural modes and the corresponding natural frequencies of a Multi-Degree-Of-Freedom-

System. The other demonstrates the balancing techniques.

Part I

MODELLING AND ANALYSIS

Modelling is the part of solution of an engineering problems that aims towards producing its mathematical description. This mathematical description can be obtained by taking advantage of the known laws of physics. These laws can not be directly applied to the real system. Therefore it is necessary to introduce many assumptions that simplify the engineering problems to such extent that the physics laws may be applied. This part of modelling is called creation of the *physical model*. Application of the physics law to the physical model yields the wanted mathematical description that is called *mathematical model*. Process of solving of the mathematical model is called *analysis* and yields solution to the problem considered. One of the most frequently encounter in engineering type of motion is the oscillatory motion of a mechanical system about its equilibrium position. Such a type of motion is called *vibration*. This part deals with study of linear vibrations of mechanical system.

Chapter 1
MECHANICAL VIBRATION OF ONE-DEGREE-OF-FREEDOM
LINEAR SYSTEMS

DEFINITION: Any oscillatory motion of a mechanical system about its equilibrium position is called *vibration*.

1.1 MODELLING OF ONE-DEGREE-OF-FREEDOM SYSTEM

DEFINITION: *Modelling* is the part of solution of an engineering problem that aims for producing its mathematical description.

The mathematical description of the engineering problem one can obtain by taking advantage of the known laws of physics. These laws can not be directly applied to the real system. Therefore it is necessary to introduce many assumptions that simplify the problem to such an extent that the physics laws may be applied. This part of modelling is called creation of the *physical model*. Application of the physics law to the physical model yields the wanted mathematical description which is called *mathematical model*.

1.1.1 *Physical model*

As an example of vibration let us consider the vertical motion of the body *1* suspended on the rod *2* shown in Fig. 1. If the body is forced out from its equilibrium position and then it is released, each point of the system performs an independent oscillatory motion. Therefore, in general, one has to introduce an infinite number of independent coordinates x_i to determine uniquely its motion.

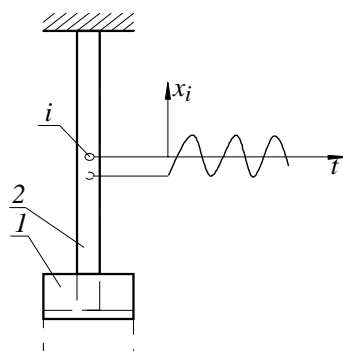

Figure 1

DEFINITION: The number of independent coordinates one has to use to determine the position of a mechanical system is called *number of degrees of freedom*

According to this definition each real system has an infinite number of degrees of freedom. Adaptation of certain assumptions, in many cases, may results in reduction of this number of degrees of freedom. For example, if one assume that the rod *2* is massless and the body *1* is rigid, only one coordinate is sufficient to determine uniquely the whole system. The displacement x of the rigid body *1* can be chosen as the independent coordinate (see Fig. 2).

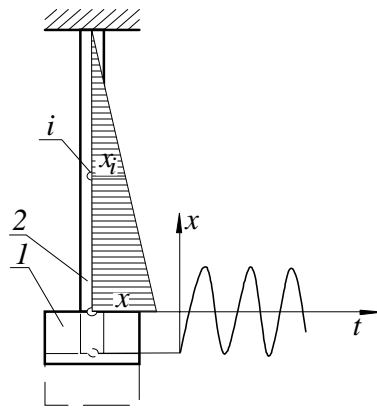

Figure 2

Position x_i of all the other points of our system depends on x . If the rod is uniform, its instantaneous position as a function of x is shown in Fig. 2. The following analysis will be restricted to system with one degree of freedom only.

To produce the equation of the vibration of the body *1*, one has to produce its free body diagram. In the case considered the free body diagram is shown in Fig. 3.

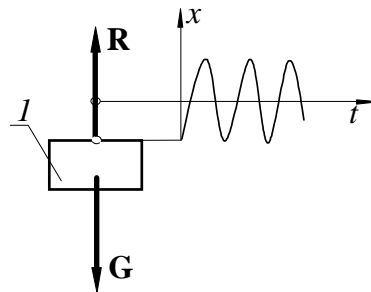

Figure 3

The gravity force is denoted by \mathbf{G} whereas the force \mathbf{R} represents so called *restoring force*. In a general case, the restoring force \mathbf{R} is a non-linear function of

the displacement x and the instantaneous velocity \dot{x} of the body 1 ($\mathbf{R} = \mathbf{R}(x, \dot{x})$). The relationship between the restoring force R and the elongation x as well as the velocity \dot{x} is shown in Fig. 4a) and b) respectively.

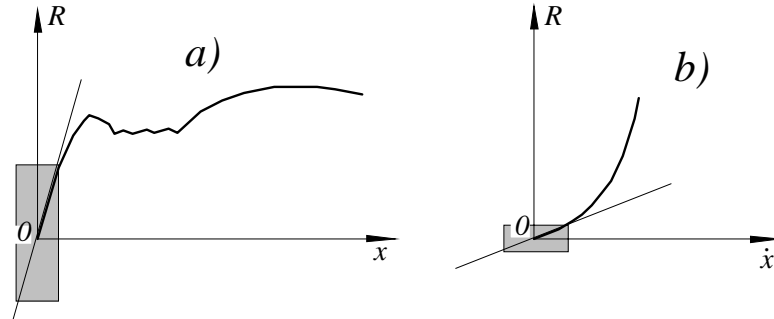

Figure 4

If it is possible to limit the consideration to vibration within a small vicinity of the system equilibrium position, the non-linear relationship, shown in Fig. 4 can be linearized.

$$R=R(x, \dot{x}) \approx kx + c\dot{x} \tag{1.1}$$

The first term represents the system elasticity and the second one reflects the system's ability for dissipation of energy. k is called *stiffness* and c is called *coefficient of damping*. The future analysis will be limited to cases for which such a linearization is acceptable from the engineering point of view. Such cases usually are referred to as *linear vibration* and the system considered is called *linear system*.

Result of this part of modelling is called *physical model*. The physical model that reflects all the above mentioned assumption is called *one-degree-of-freedom linear system*. For presentation of the physical model we use symbols shown in the Fig. 5.

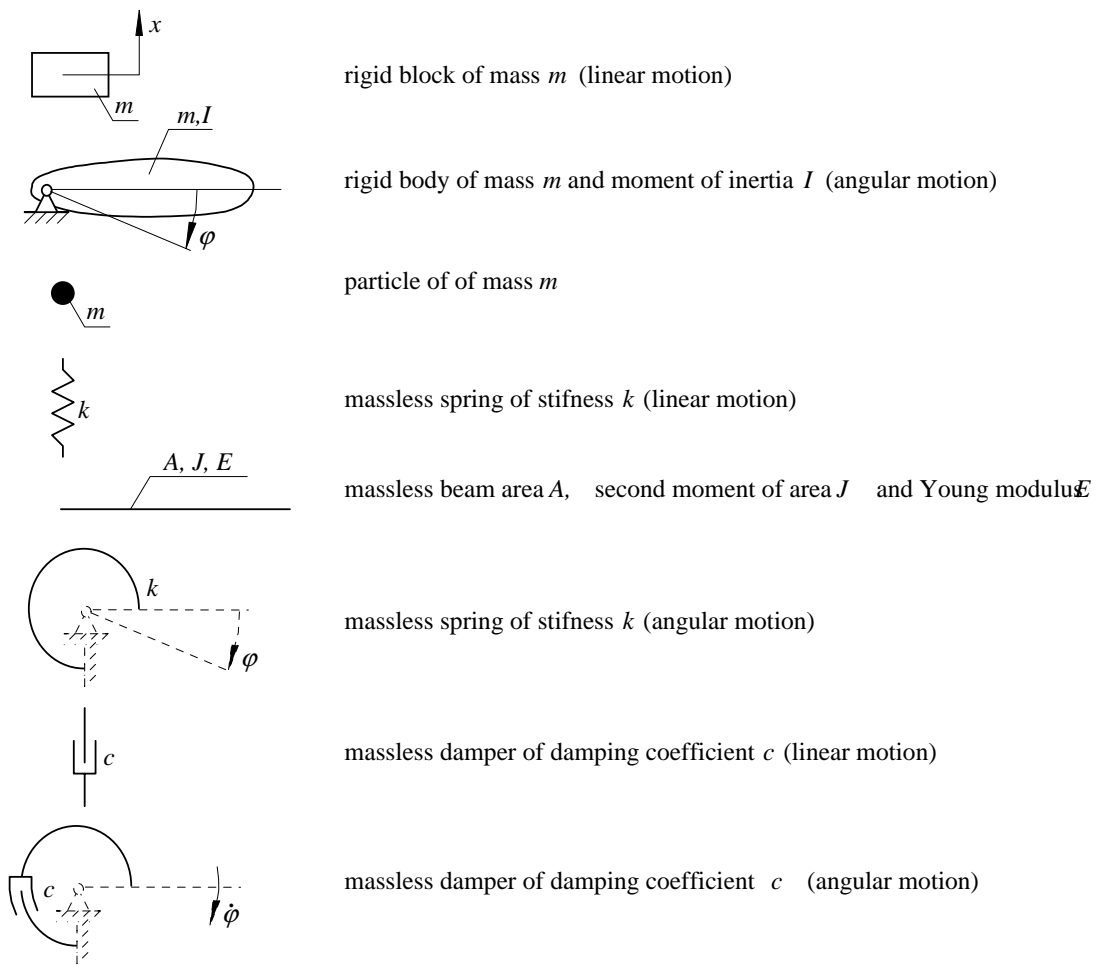

Figure 5

1.1.2 *Mathematical model*

To analyze motion of a system it is necessary to develop a mathematical description that approximates its dynamic behavior. This mathematical description is referred to as the *mathematical model*. This mathematical model can be obtained by application of the known physical laws to the adopted physical model. The creation of the physical model, has been explained in the previous section. In this section principle of producing of the mathematical model for the one-degree-of-freedom system is shown.

Let us consider system shown in Fig. 6.

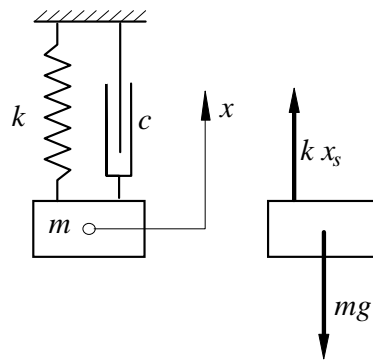

Figure 6

Let us assume that the system is in an equilibrium. To develop the mathematical model we take advantage of Newton's generalized equations. This requires the introduction of the absolute system of coordinates. In this chapter we are assuming that the origin of the absolute system of coordinates coincides with the centre of gravity of the body while the body stays at its equilibrium position as shown in Fig. 6. The resultant force of all static forces (in the example considered gravity force mg and interaction force due to the static elongation of spring kx_s) is equal to zero. Therefore, these forces do not have to be included in Newton's equations. If the system is out of the equilibrium position (see Fig. 7) by a distance x , there is an increment in the interaction force between the spring and the block. This increment is called *restoring force*.

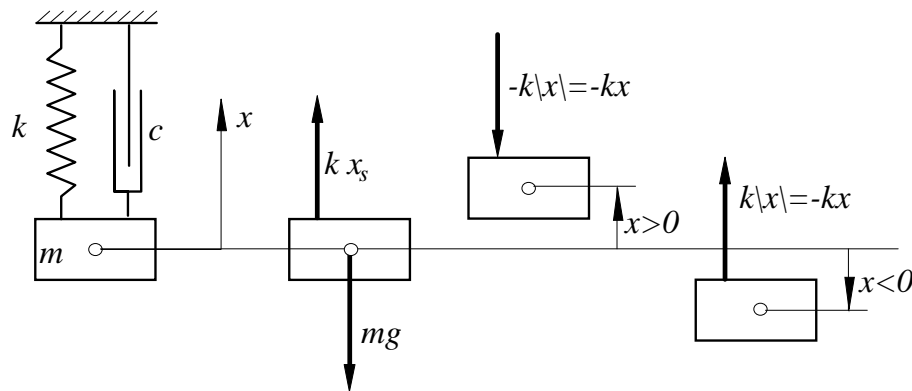

Figure 7

In our case the magnitude of the restoring force is $|F_R| = k|x|$

If $x > 0$, the restoring force is opposite to the positive direction of axis x .

Hence $F_R = -k|x| = -kx$

If $x < 0$, the restoring force has the same direction as axis x . Hence $F_R =$

$+k|x| = -kx$

Therefore the restoring force always can be represented in the equation of motion by term

$$F_R = -kx \tag{1.2}$$

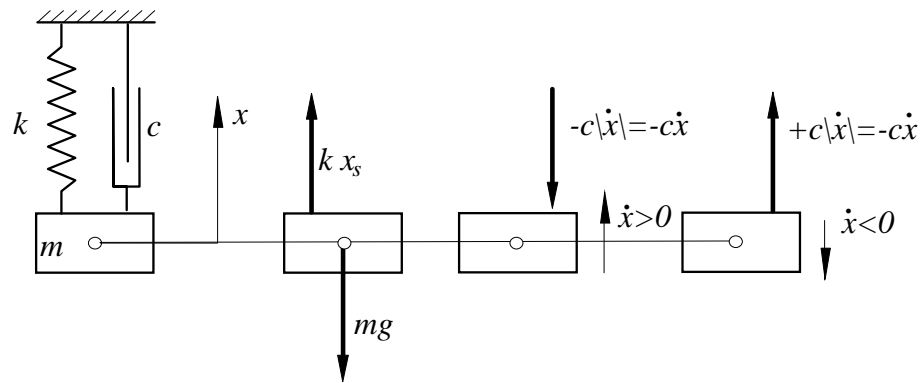

Figure 8

Creating the equation of motion one has to take into consideration the interaction force between the damper and the block considered (see Fig. 8). This interaction force is called *damping force* and its absolute value is $|F_D| = c|\dot{x}|$. A very similar to the above consideration leads to conclusion that the damping force can be represented in the equation of motion by the following term

$$F_D = -c\dot{x} \tag{1.3}$$

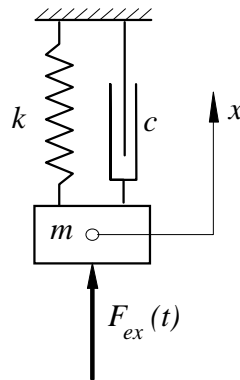

Figure 9

The assumption that the system is linear allows to apply the superposition rules and add these forces together with the external force $F_{ex}(t)$ (see Fig. 9). Hence, the equation of motion of the block of mass m

$$m\ddot{x} = -kx - c\dot{x} + F_{ex}(t) \tag{1.4}$$

Transformation of the above equation into the standard form yields

$$\ddot{x} + 2\zeta\omega_n\dot{x} + \omega_n^2x = f(t) \tag{1.5}$$

where

$$\omega_n = \sqrt{\frac{k}{m}}; \quad 2\zeta\omega_n = \frac{c}{m}; \quad f(t) = \frac{F_{ex}(t)}{m} \quad (1.6)$$

ω_n - is called *natural frequency of the undamped system*

ζ - is called *damping factor or damping ratio*

$f(t)$ - is called *unit external excitation*

The equation 1.5 is known as *the mathematical model of the linear vibration of the one-degree-of-freedom system.*

1.1.3 Problems

Problem 1

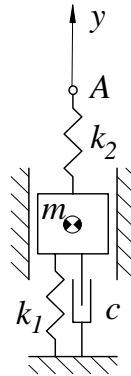

Figure 10

The block of mass m (see Fig. 10) is restricted to move along the vertical axis. It is supported by the spring of stiffness k_1 , the spring of stiffness k_2 and the damper of damping coefficient c . The upper end of the spring k_2 moves along the inertial axis y and its motion is governed by the following equation

$$y_A = a \sin \omega t$$

where a is the amplitude of motion and ω is its angular frequency. Produce the equation of motion of the block.

Solution

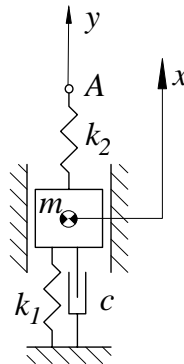

Figure 11

Let us introduce the inertial axis x in such a way that its origin coincides with the centre of gravity of the block 1 when the system is in its equilibrium position (see Fig. 11). Application of the Newton's law results in the following equation of motion

$$m\ddot{x} = -k_2x - k_1x + k_2y - c\dot{x} \tag{1.7}$$

Its standard form is

$$\ddot{x} + 2\zeta\omega_n\dot{x} + \omega_n^2x = q \sin \omega t \tag{1.8}$$

where

$$\omega_n^2 = \frac{k_1 + k_2}{m} \quad 2\zeta\omega_n = \frac{c}{m} \quad q = \frac{k_2a}{m} \tag{1.9}$$

Problem 2

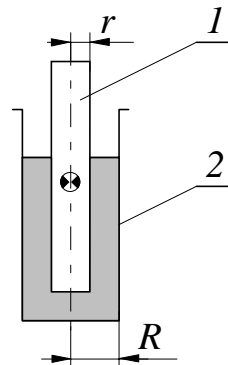

Figure 12

The cylinder 1 (see Fig. 12) of mass m and radius r is plunged into a liquid of density d . The cylindric container 2 has a radius R . Produce the formula for the period of the vertical oscillation of the cylinder.

Solution

Figure 13

Let us introduce the inertial axis x in such a way that its origin coincides with the centre of gravity of the cylinder 1 when the system is in its equilibrium position (see Fig. 13). If the cylinder is displaced from its equilibrium position by a distance x , the hydrostatic force acting on the cylinder is reduced by

$$\Delta H = (x + z) dg\pi r^2 \quad (1.10)$$

Since the volume V_1 must be equal to the volume V_2 we have

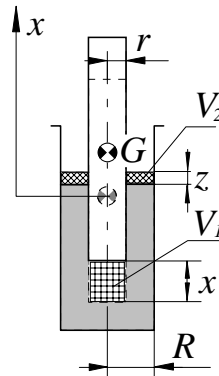
$$V_1 = \pi r^2 x = V_2 = \pi (R^2 - r^2) z \quad (1.11)$$

Therefore

$$z = \frac{r^2}{R^2 - r^2} x \quad (1.12)$$

Introducing the above relationship into the formula 1.10 one can get that

$$\Delta H = \left(x + \frac{r^2}{R^2 - r^2} x \right) dg\pi r^2 = \pi dg \left(\frac{R^2 r^2}{R^2 - r^2} \right) x \quad (1.13)$$

According to the Newton's law we have

$$m\ddot{x} = -dg\pi \left(\frac{R^2 r^2}{R^2 - r^2} \right) x \quad (1.14)$$

The standard form of this equation of motion is

$$\ddot{x} + \omega_n^2 x = 0 \quad (1.15)$$

where

$$\omega_n^2 = \frac{dg}{m} \pi \left(\frac{R^2 r^2}{R^2 - r^2} \right) \quad (1.16)$$

The period of the free oscillation of the cylinder is

$$T_n = \frac{2\pi}{\omega_n} = \frac{2\pi}{Rr} \sqrt{\frac{m(R^2 - r^2)}{\pi dg}} = \frac{2}{Rr} \sqrt{\frac{m\pi(R^2 - r^2)}{dg}} \quad (1.17)$$

Problem 3

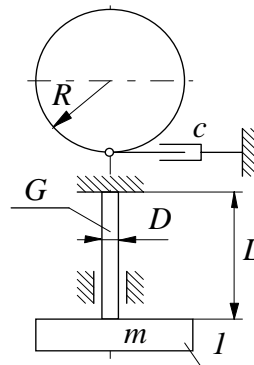

Figure 14

The disk 1 of mass m and radius R (see Fig. 14) is supported by an elastic shaft of diameter D and length L . The elastic properties of the shaft are determined by the shear modulus G . The disk can oscillate about the vertical axis and the damping is modelled by the linear damper of a damping coefficient c . Produce equation of motion of the disk

Solution

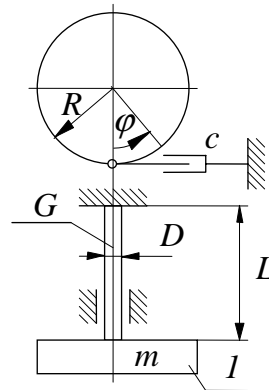

Figure 15

Motion of the disk is governed by the generalized Newton's equation

$$I\ddot{\phi} = -k_s\phi - cR^2\dot{\phi} \tag{1.18}$$

where

$I = \frac{mR^2}{2}$ - the moment of inertia of the disk

$k_s = \frac{T}{\phi} = \frac{T}{\frac{TL}{JG}} = \frac{JG}{L} = \frac{\pi D^4G}{32L}$ the stiffness of the rod

Introduction of the above expressions into the equation 1.18 yields

$$I\ddot{\phi} + cR^2\dot{\phi} + \frac{\pi D^4G}{32L}\phi = 0 \tag{1.19}$$

or

$$\ddot{\phi} + 2\zeta\omega_n\dot{\phi} + \omega_n^2\phi = 0 \tag{1.20}$$

where

$$\omega_n^2 = \frac{\pi D^4G}{32LI} \quad 2\zeta\omega_n = \frac{cR^2}{I} \tag{1.21}$$

Problem 4

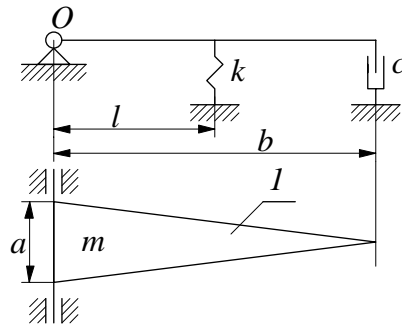

Figure 16

The thin and uniform plate l of mass m (see Fig. 16) can rotate about the horizontal axis O . The spring of stiffness k keeps it in the horizontal position. The damping coefficient c reflects dissipation of energy of the system. Produce the equation of motion of the plate.

Solution

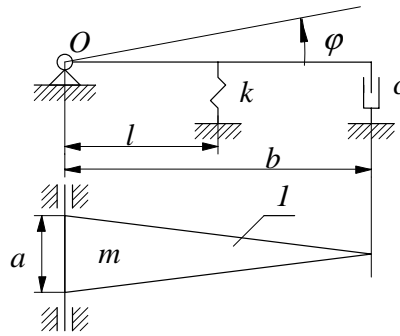

Figure 17

Motion of the plate along the coordinate φ (see Fig. 17) is governed by the generalized Newton's equation

$$I\ddot{\varphi} = M \tag{1.22}$$

The moment of inertia of the plate 1 about its axis of rotation is

$$I = \frac{mb^2}{6} \tag{1.23}$$

The moment which act on the plate due to the interaction with the spring k and the damper c is

$$M = -kl^2\varphi - cb^2\dot{\varphi} \tag{1.24}$$

Hence

$$\frac{mb^2}{6}\ddot{\varphi} + kl^2\varphi + cb^2\dot{\varphi} = 0 \tag{1.25}$$

or

$$\ddot{\varphi} + 2\zeta\omega_n\dot{\varphi} + \omega_n^2\varphi = 0 \tag{1.26}$$

where

$$\omega_n^2 = \frac{6kl^2}{mb^2} \quad 2\zeta\omega_n = \frac{6c}{m} \tag{1.27}$$

Problem 5

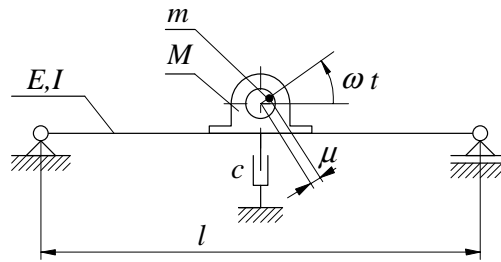

Figure 18

The electric motor of mass M (see Fig. 18) is mounted on the massless beam of length l , the second moment of inertia of its cross-section I and the Young modulus E . The shaft of the motor has a mass m and rotates with the angular velocity ω . Its unbalance (the distance between the axis of rotation and the shaft centre of gravity) is μ . The damping properties of the system are modelled by the linear damping of the damping coefficient c . Produce the equation of motion of the system.

Problem 6

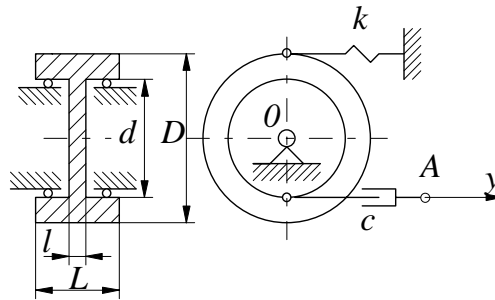

Figure 19

The wheel shown in the Fig. 19 is made of the material of a density ρ . It can oscillate about the horizontal axis O . The wheel is supported by the spring of stiffness k and the damper of the damping coefficient c . The right hand end of the damper moves along the horizontal axis y and its motion is given by the following equation

$$y = a \sin \omega t$$

Produce the equation of motion of the system

Problem 7

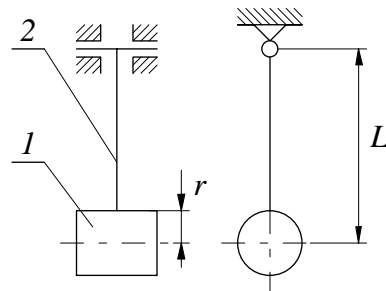

Figure 20

The cylinder 1 of mass m is attached to the rigid and massless rod 2 to form the pendulum shown in the Fig. 20. Produce the formula for the period of oscillation of the pendulum.

Problem 8

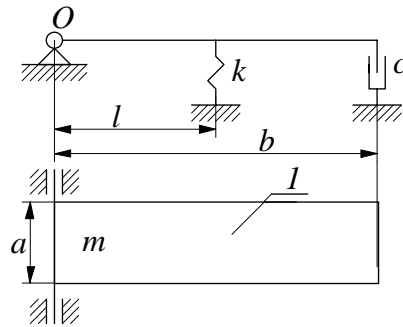

Figure 21

The thin and uniform plate 1 (see Fig. 21) of mass m can rotate about the horizontal axis O . The spring of stiffness k keeps it in the horizontal position. The damping coefficient c reflects dissipation of energy of the system. Produce the formula for the natural frequency of the system.

1.2 ANALYSIS OF ONE-DEGREE-OF-FREEDOM SYSTEM

1.2.1 Free vibration

DEFINITION: It is said that a system performs *free vibration* if there are **no external forces** (forces that are explicitly dependent on time) **acting on this system**.

In this section, according to the above definition, it is assumed that the resultant of all external forces $f(t)$ is equal to zero. Hence, the mathematical model that is analyzed in this section takes form

$$\ddot{x} + 2\zeta\omega_n\dot{x} + \omega_n^2x = 0 \quad (1.28)$$

The equation 1.28 is classified as *linear homogeneous ordinary differential equation of second order*. If one assume that the damping ratio ζ is equal to zero, the equation 1.28 governs the free motion of the *undamped system*.

$$\ddot{x} + \omega_n^2x = 0 \quad (1.29)$$

Free vibration of an undamped system

The general solution of the homogeneous equation 1.29 is a linear combination of its two particular linearly independent solutions. These solutions can be obtained by means of the following procedure. The particular solution can be predicted in the form 1.30.

$$x = e^{\lambda t} \quad (1.30)$$

Introduction of the solution 1.30 into the equation 1.29 yields the characteristic equation

$$\lambda^2 + \omega_n^2 = 0 \quad (1.31)$$

This characteristic equation has two roots

$$\lambda_1 = +i\omega_n \quad \text{and} \quad \lambda_2 = -i\omega_n \quad (1.32)$$

Hence, in this case, the independent particular solution are

$$x_1 = \sin \omega_n t \quad \text{and} \quad x_2 = \cos \omega_n t \quad (1.33)$$

Their linear combination is the wanted general solution and approximates the free vibration of the undamped system.

$$x = C_s \sin \omega_n t + C_c \cos \omega_n t \quad (1.34)$$

The two constants C_s and C_c should be chosen to fulfill the initial conditions which reflect the way the free vibrations were initiated. To get an unique solution it is necessary to specify the initial position and the initial velocity of the system considered. Hence, let us assume that at the instant $t = 0$ the system was at the position x_0 and was forced to move with the initial velocity v_0 . Introduction of these initial conditions

into the equation 1.34 results in two algebraic equation that are linear with respect to the unknown constants C_s and C_c .

$$\begin{aligned} C_c &= x_0 \\ C_s \omega_n &= v_0 \end{aligned} \quad (1.35)$$

According to 1.34, the particular solution that represents the free vibration of the system is

$$\begin{aligned} x &= \frac{v_0}{\omega_n} \sin \omega_n t + x_0 \cos \omega_n t = \\ &= C \sin(\omega_n t + \alpha) \end{aligned} \quad (1.36)$$

where

$$C = \sqrt{(x_0)^2 + \left(\frac{v_0}{\omega_n}\right)^2}; \quad \alpha = \arctan\left(\frac{x_0}{\frac{v_0}{\omega_n}}\right) \quad (1.37)$$

For $\omega_n = 1[1/s]$, $x_0 = 1[m]$ $v_0 = 1[m/s]$ and $\zeta = 0$ the free motion is shown in Fig. 22 The free motion, in the case considered is periodic.

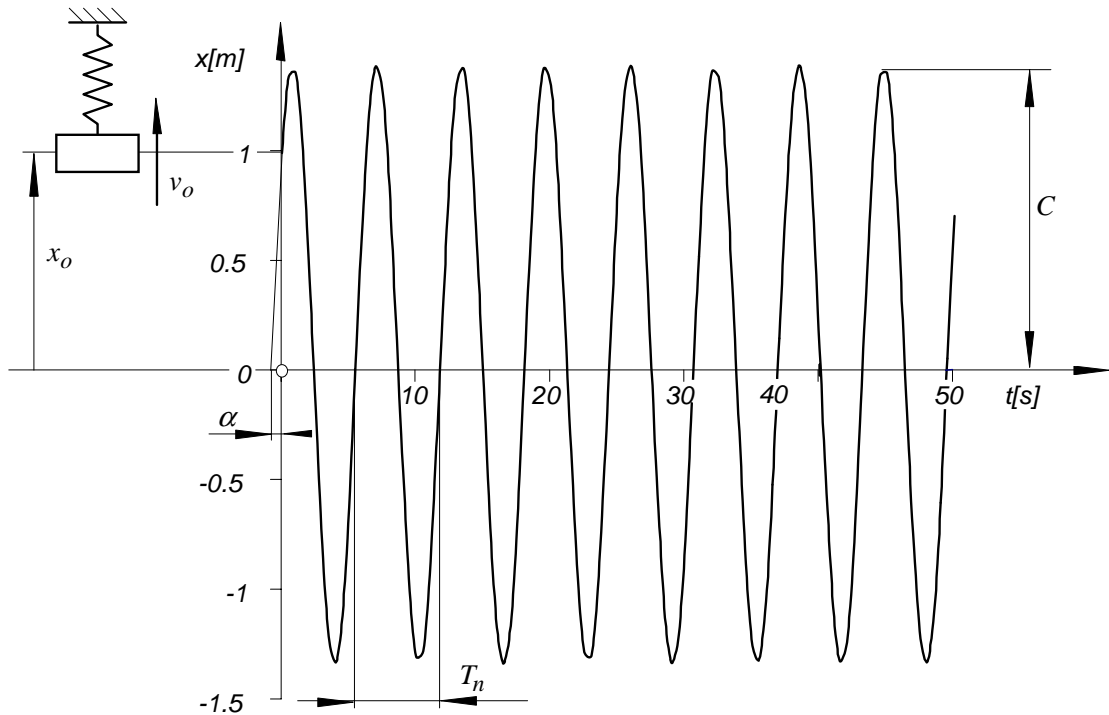

Figure 22

DEFINITION: The shortest time after which parameters of motion repeat themselves is called *period* and the motion is called *periodic motion*.

According to this definition, since the sine function has a period equal to 2π , we have

$$\sin(\omega_n(t + T_n) + \alpha) = \sin(\omega_n t + \alpha + 2\pi) \quad (1.38)$$

Hence, the period of the undamped free vibrations is

$$T_n = \frac{2\pi}{\omega_n} \quad (1.39)$$

Free vibration of a damped system

If the damping ratio is not equal to zero, the equation of the free motion is

$$\ddot{x} + 2\zeta\omega_n\dot{x} + \omega_n^2x = 0 \quad (1.40)$$

Introduction of the equation 1.30 into 1.40 yields the characteristic equation

$$\lambda^2 + 2\zeta\omega_n\lambda + \omega_n^2 = 0 \quad (1.41)$$

The characteristic equation has two roots

$$\lambda_{1,2} = \frac{-2\zeta\omega_n \pm \sqrt{(2\zeta\omega_n)^2 - 4\omega_n^2}}{2} = -\zeta\omega_n \pm \omega_n\sqrt{\zeta^2 - 1} \quad (1.42)$$

The particular solution depend on category of the above roots. Three cases are possible

Case one - underdamped vibration

If $\zeta < 1$, the characteristic equation has two complex conjugated roots and this case is often referred to as the *underdamped vibration*.

$$\lambda_{1,2} = -\zeta\omega_n \pm i\omega_n\sqrt{1 - \zeta^2} = -\zeta\omega_n \pm i\omega_d \quad (1.43)$$

where

$$\omega_d = \omega_n\sqrt{1 - \zeta^2} \quad (1.44)$$

The particular solutions are

$$x_1 = e^{-\zeta\omega_n t} \sin \omega_d t \quad \text{and} \quad x_2 = e^{-\zeta\omega_n t} \cos \omega_d t \quad (1.45)$$

and their linear combination is

$$x = e^{-\zeta\omega_n t} (C_s \sin \omega_d t + C_c \cos \omega_d t) \quad (1.46)$$

For the following initial conditions

$$x|_{t=0} = x_0 \quad \dot{x}|_{t=0} = v_0 \quad (1.47)$$

the two constants C_s and C_c are

$$\begin{aligned} C_s &= \frac{v_0 + \zeta\omega_n x_0}{\omega_d} \\ C_c &= x_0 \end{aligned} \quad (1.48)$$

Introduction of the expressions 1.48 into 1.46 produces the free motion in the following form

$$x = e^{-\zeta\omega_n t}(C_s \sin \omega_d t + C_c \cos \omega_d t) = C e^{-\zeta\omega_n t} \sin(\omega_d t + \alpha) \quad (1.49)$$

where

$$C = \sqrt{\left(\frac{v_0 + \zeta\omega_n x_0}{\omega_d}\right)^2 + (x_0)^2}; \quad \alpha = \arctan \frac{x_0 \omega_d}{v_0 + \zeta\omega_n x_0}; \quad \omega_d = \omega_n \sqrt{1 - \zeta^2} \quad (1.50)$$

For $\omega_n = 1[1/s]$, $x_0 = 1[m]$ $v_0 = 1[m/s]$ and $\zeta = .1$ the free motion is shown in Fig. 23. In this case the motion is not periodic but the time T_d (see Fig. 23) between every

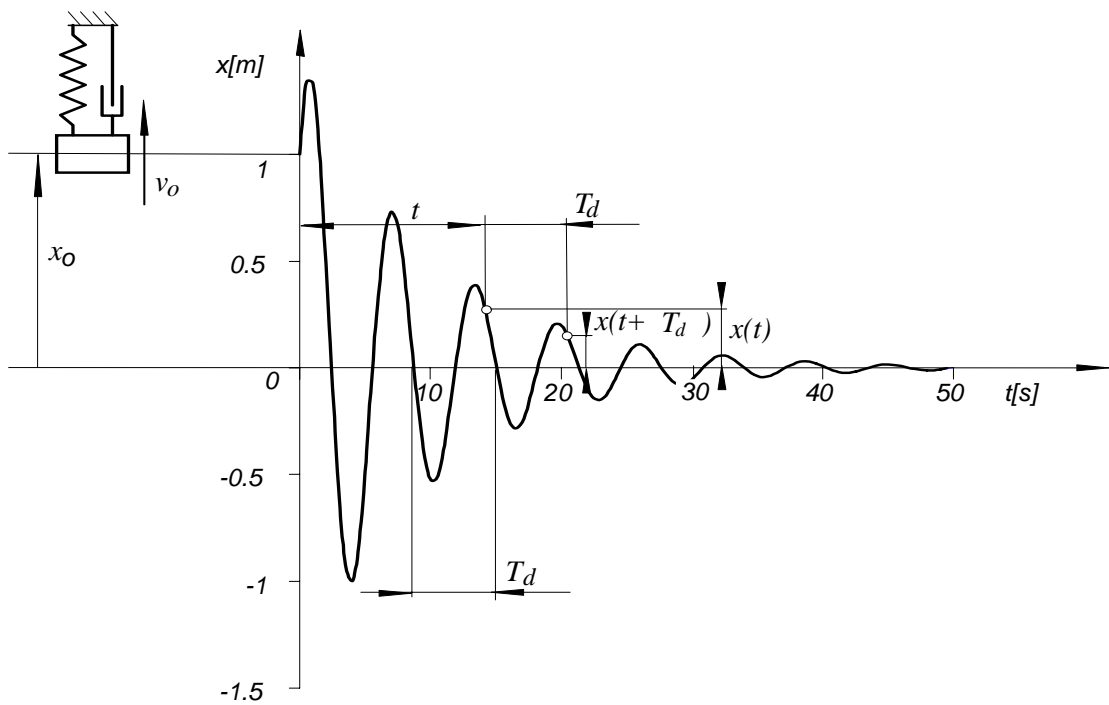

Figure 23

second zero-point is constant and it is called *period of the damped vibration*. It is easy to see from the expression 1.49 that

$$T_d = \frac{2\pi}{\omega_d} \quad (1.51)$$

DEFINITION: Natural logarithm of ratio of two displacements $x(t)$ and $x(t + T_d)$ that are one period apart is called *logarithmic decrement of damping* and will be denoted by δ .

It will be shown that the logarithmic decrement is constant. Indeed

$$\begin{aligned}
 \delta &= \ln \frac{x(t)}{x(t+T_d)} = \ln \frac{C e^{-\zeta \omega_n t} \sin(\omega_d t + \alpha)}{C e^{-\zeta \omega_n (t+T_d)} \sin(\omega_d (t+T_d) + \alpha)} = \\
 &= \ln \frac{C e^{-\zeta \omega_n t} \sin(\omega_d t + \alpha)}{C e^{-\zeta \omega_n t} e^{-\zeta \omega_n T_d} \sin(\omega_d t + 2\pi + \alpha)} = \zeta \omega_n T_d = \frac{2\pi \zeta \omega_n}{\omega_d} = \frac{2\pi \zeta \omega_n}{\omega_n \sqrt{1 - \zeta^2}} = \\
 &= \frac{2\pi \zeta}{\sqrt{1 - \zeta^2}} \tag{1.52}
 \end{aligned}$$

This formula is frequently used for the experimental determination of the damping ratio ζ .

$$\zeta = \frac{\delta}{\sqrt{4\pi^2 + \delta^2}} \tag{1.53}$$

The other parameter ω_n that exists in the mathematical model 1.40 can be easily identified by measuring the period of the free motion T_d . According to the formula 1.44 and 1.51

$$\omega_n = \frac{\omega_d}{\sqrt{1 - \zeta^2}} = \frac{2\pi}{T_d \sqrt{1 - \zeta^2}} \tag{1.54}$$

Case two - critically damped vibration

If $\zeta = 1$, the characteristic equation has two real and equal one to each other roots and this case is often referred to as the *critically damped vibration*

$$\lambda_{1,2} = -\zeta \omega_n \tag{1.55}$$

The particular solutions are

$$x_1 = e^{-\zeta \omega_n t} \quad \text{and} \quad x_2 = t e^{-\zeta \omega_n t} \tag{1.56}$$

and their linear combination is

$$x = C_s e^{-\zeta \omega_n t} + C_c t e^{-\zeta \omega_n t} \tag{1.57}$$

For the following initial conditions

$$x|_{t=0} = x_0 \quad \dot{x}|_{t=0} = v_0 \tag{1.58}$$

the two constants C_s and C_c are as follow

$$\begin{aligned}
 C_s &= x_0 \\
 C_c &= v_0 + x_0 \omega_n
 \end{aligned} \tag{1.59}$$

Introduction of the expressions 1.59 into 1.57 produces expression for the free motion in the following form

$$x = e^{-\zeta \omega_n t} (x_0 + t(v_0 + x_0 \omega_n)) \tag{1.60}$$

For $\omega_n = 1[1/s]$, $x_0 = 1[m]$ $v_0 = 1[m/s]$ and $\zeta = 1$. the free motion is shown in Fig. 24. The critical damping offers for the system the possibly faster return to its equilibrium position.

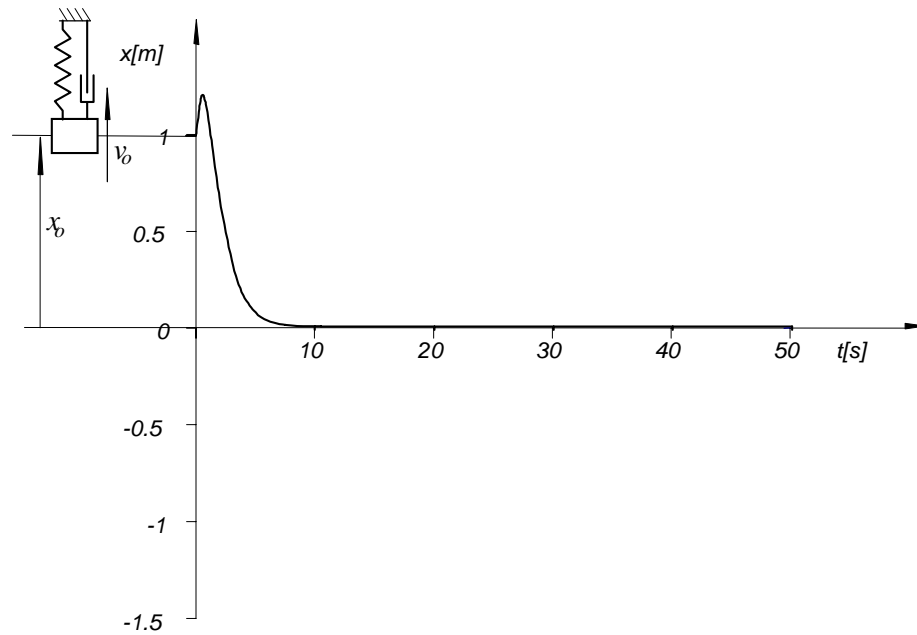

Figure 24

Case three - overdamped vibration

If $\zeta > 1$, the characteristic equation has two real roots and this case is often referred to as the *overdamped vibration*.

$$\lambda_{1,2} = -\zeta\omega_n \pm \omega_n\sqrt{\zeta^2 - 1} = \omega_n(-\zeta \pm \sqrt{\zeta^2 - 1}) \quad (1.61)$$

The particular solutions are

$$x_1 = e^{-\omega_n(\zeta + \sqrt{\zeta^2 - 1})t} \quad \text{and} \quad x_2 = e^{-\omega_n(\zeta - \sqrt{\zeta^2 - 1})t} \quad (1.62)$$

and their linear combination is

$$x = e^{-\omega_n t} \left(C_s e^{\omega_n \sqrt{\zeta^2 - 1} t} + C_c e^{-\omega_n \sqrt{\zeta^2 - 1} t} \right) \quad (1.63)$$

For the following initial conditions

$$x|_{t=0} = x_0 \quad \dot{x}|_{t=0} = v_0 \quad (1.64)$$

the two constants C_s and C_c are as follow

$$\begin{aligned} C_s &= \frac{+\frac{v_0}{\omega_n} + x_0(+\zeta + \sqrt{\zeta^2 - 1})}{2\sqrt{\zeta^2 - 1}} \\ C_c &= \frac{-\frac{v_0}{\omega_n} + x_0(-\zeta + \sqrt{\zeta^2 - 1})}{2\sqrt{\zeta^2 - 1}} \end{aligned} \quad (1.65)$$

For $\omega_n = 1[1/s]$, $x_0 = 1[m]$, $v_0 = 1[m/s]$ and $\zeta = 5$. the free motion is shown in Fig. 25

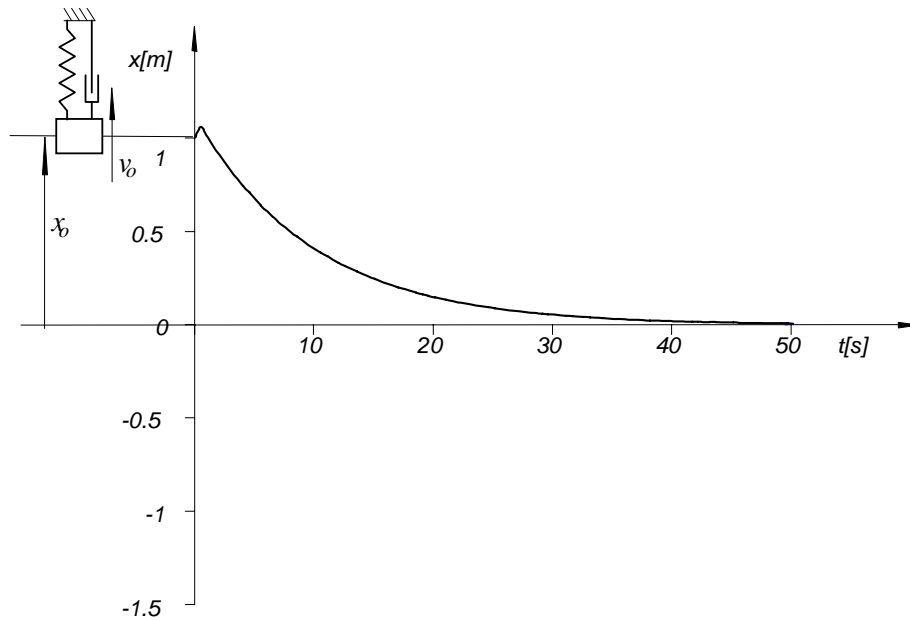

Figure 25

1.2.2 Forced vibration

In a general case motion of a vibrating system is due to both, the initial conditions and the exciting force. The mathematical model, according to the previous consideration, is the linear non-homogeneous differential equation of second order.

$$\ddot{x} + 2\zeta\omega_n\dot{x} + \omega_n^2x = f(t) \quad (1.66)$$

where

$$\omega_n = \sqrt{\frac{k}{m}}; \quad 2\zeta\omega_n = \frac{c}{m}; \quad f(t) = \frac{F_{ex}(t)}{m} \quad (1.67)$$

The general solution of this mathematical model is a superposition of the general solution of the homogeneous equation x_g and the particular solution of the non-homogeneous equation x_p .

$$x = x_g + x_p \quad (1.68)$$

The general solution of the homogeneous equation has been produced in the previous section and for the underdamped vibration it is

$$x_g = e^{-\zeta\omega_n t}(C_s \sin \omega_d t + C_c \cos \omega_d t) = Ce^{-\zeta\omega_n t} \sin(\omega_d t + \alpha) \quad (1.69)$$

To produce the particular solution of the non-homogeneous equation, let us assume that the excitation can be approximated by a harmonic function. Such a case is referred to as the *harmonic excitation*.

$$f(t) = q \sin \omega t \quad (1.70)$$

In the above equation q represents the *amplitude of the unit excitation* and ω is the *excitation frequency*. Introduction of the expression 1.70 into equation 1.66 yields

$$\ddot{x} + 2\zeta\omega_n\dot{x} + \omega_n^2x = q \sin \omega t \quad (1.71)$$

In this case it is easy to predict mode of the particular solution

$$x_p = A_s \sin \omega t + A_c \cos \omega t \quad (1.72)$$

where A_s and A_c are constant. The function 1.72 is the particular solution if and only if it fulfils the equation 1.71 for any instant of time. Therefore, implementing it in equation 1.71 one can get

$$((\omega_n^2 - \omega^2)A_s - 2\zeta\omega_n\omega A_c) \sin \omega t + (2\zeta\omega_n\omega A_s + (\omega_n^2 - \omega^2)A_c) \cos \omega t = q \sin \omega t \quad (1.73)$$

This relationship is fulfilled for any instant of time if

$$\begin{aligned} (\omega_n^2 - \omega^2)A_s - 2\zeta\omega_n\omega A_c &= q \\ 2\zeta\omega_n\omega A_s + (\omega_n^2 - \omega^2)A_c &= 0 \end{aligned} \quad (1.74)$$

Solution of the above equations yields the expression for the constant A_s and A_c

$$\begin{aligned} A_s &= \frac{\begin{vmatrix} q & -2\zeta\omega_n\omega \\ 0 & (\omega_n^2 - \omega^2) \end{vmatrix}}{\begin{vmatrix} (\omega_n^2 - \omega^2) & -2\zeta\omega_n\omega \\ 2\zeta\omega_n\omega & (\omega_n^2 - \omega^2) \end{vmatrix}} = \frac{(\omega_n^2 - \omega^2)q}{(\omega_n^2 - \omega^2)^2 + 4(\zeta\omega_n)^2\omega^2} \\ A_c &= \frac{\begin{vmatrix} (\omega_n^2 - \omega^2) & q \\ 2\zeta\omega_n\omega & 0 \end{vmatrix}}{\begin{vmatrix} (\omega_n^2 - \omega^2) & -2\zeta\omega_n\omega \\ 2\zeta\omega_n\omega & (\omega_n^2 - \omega^2) \end{vmatrix}} = \frac{-2(\zeta\omega_n)\omega q}{(\omega_n^2 - \omega^2)^2 + 4(\zeta\omega_n)^2\omega^2} \end{aligned} \quad (1.75)$$

Introduction of the expressions 1.75 into the predicted solution 1.72 yields

$$x_p = A_s \sin \omega t + A_c \cos \omega t = A \sin(\omega t + \varphi) \quad (1.76)$$

where

$$A = \sqrt{A_s^2 + A_c^2} = \frac{q}{\sqrt{(\omega_n^2 - \omega^2)^2 + 4(\zeta\omega_n)^2\omega^2}} \quad \varphi = \arctan \frac{A_c}{A_s} = -\arctan \frac{2(\zeta\omega_n)\omega}{\omega_n^2 - \omega^2} \quad (1.77)$$

or

$$A = \frac{\frac{q}{\omega_n^2}}{\sqrt{\left(1 - \left(\frac{\omega}{\omega_n}\right)^2\right)^2 + 4\zeta^2\left(\frac{\omega}{\omega_n}\right)^2}} \quad \varphi = -\arctan \frac{2\zeta\frac{\omega}{\omega_n}}{1 - \left(\frac{\omega}{\omega_n}\right)^2} \quad (1.78)$$

Introducing 1.69 and 1.76 into the 1.68 one can obtain the general solution of the equation of motion 1.71 in the following form

$$x = C e^{-\zeta\omega_n t} \sin(\omega_d t + \alpha) + A \sin(\omega t + \varphi) \quad (1.79)$$

The constants C and α should be chosen to fulfill the required initial conditions.

For the following initial conditions

$$x|_{t=0} = x_0 \quad \dot{x}|_{t=0} = v_0 \quad (1.80)$$

one can get the following set of the algebraic equations for determination of the parameters C and α

$$\begin{aligned} x_0 &= C_o \sin \alpha_o + A \sin \varphi \\ v_0 &= -C_o \zeta \omega_n \sin \alpha_o + C_o \omega_d \cos \alpha_o + A \omega \cos \varphi \end{aligned} \quad (1.81)$$

Introduction of the solution of the equations 1.81 (C_o, α_o) to the general solution, yields particular solution of the non-homogeneous equation that represents the forced vibration of the system considered.

$$x = C_o e^{-\zeta \omega_n t} \sin(\omega_d t + \alpha_o) + A \sin(\omega t + \varphi) \quad (1.82)$$

This solution, for the following numerical data $\zeta = 0.1$, $\omega_n = 1[1/s]$, $\omega = 2[1/s]$, $C_o = 1[m]$, $\alpha_o = 1[rd]$, $A = 0.165205[m]$, $\varphi = 0.126835[rd]$ is shown in Fig. 26 (curve c). The solution 1.82 is assembled out of two terms. First term represents an

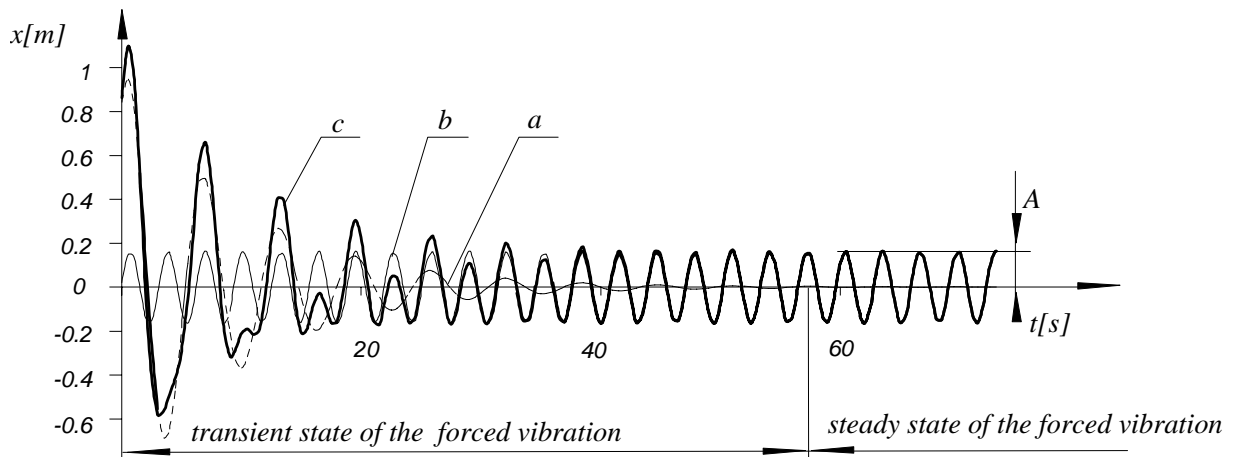

Figure 26

oscillations with frequency equal to the natural frequency of the damped system ω_d . Motion represented by this term, due to the existing damping, decays to zero (curve a in Fig. 1.82) and determines time of the *transient state* of the forced vibrations. Hence, after an usually short time, the transient state changes into the *steady state* represented by the second term in equation 1.82 (curve b in Fig. 1.82)

$$x = A \sin(\omega t + \varphi) \quad (1.83)$$

This harmonic term has amplitude A determined by the formula 1.77. It does not depend on the initial conditions and is called *amplitude of the forced vibration*. Motion approximated by the equation 1.83 is usually referred to as the system forced vibration.

Both, the exciting force $f(t) = q \sin \omega t$ (1.70) and the (steady state) forced vibration $x = A \sin(\omega t + \varphi)$ (1.83) are harmonic. Therefore, they can be represented by means of two vectors 'rotating' with the same angular velocity ω (see Fig. 27). One

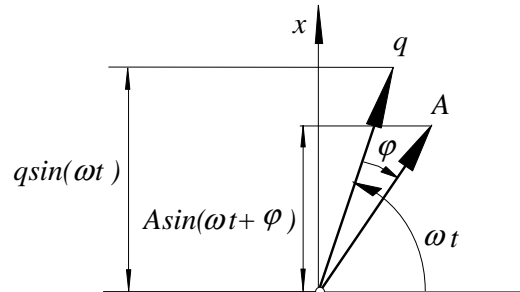

Figure 27

can see from the above interpretation that the angular displacement φ is the phase between the exciting force and the displacement it causes. Therefore φ is called *phase of the forced vibration*.

Because the transient state, from engineering point of view play secondary role, in the following sections the steady state forced vibration will be considered only.

Forced response due to rotating elements - force transmitted to foundation.

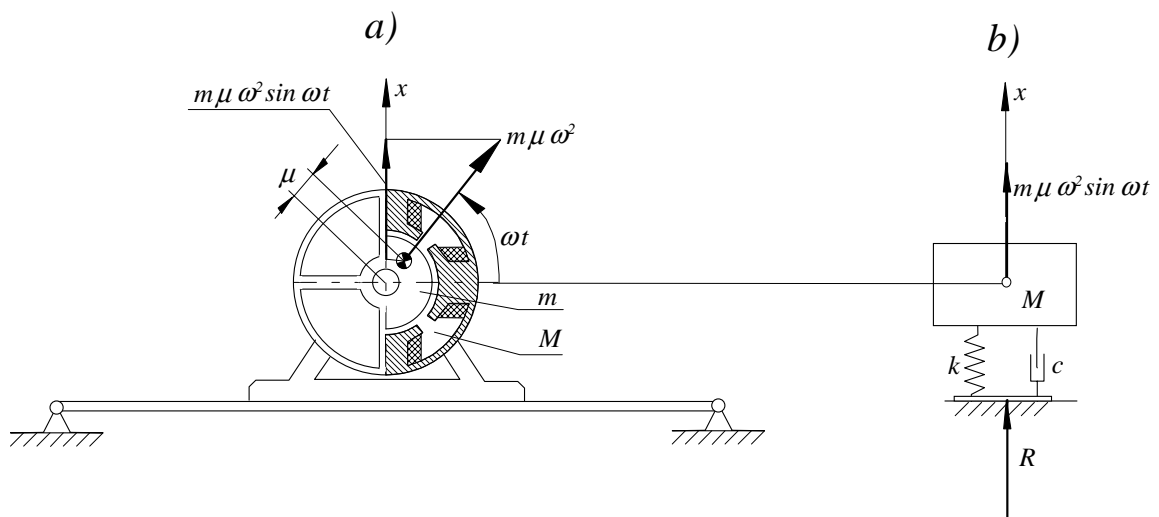

Figure 28

One of many possible excitation of vibrations is excitation caused by inertia forces produced by moving elements. The possibly simplest case of vibration caused by this type of excitation is shown in Fig. 28. The rotor of an electrical motor rotates with the constant angular velocity ω . If μ represents the static imbalance of the rotor

and m is its mass, then the rotor produces the centrifugal force

$$F = m\mu\omega^2 \quad (1.84)$$

Its component along the vertical axis x is

$$F_x = m\mu\omega^2 \sin \omega t \quad (1.85)$$

The motor of mass M is supported by means of a beam of the stiffness k . The damping properties are approximated by the damping coefficient c . Let us model vibration of the system. The physical model of the problem described is shown in Fig. 28b). Taking advantage of the earlier described method of formulation the mathematical model we have

$$M\ddot{x} = -kx - c\dot{x} + m\mu\omega^2 \sin \omega t \quad (1.86)$$

Transformation of this equation into the standard form yields

$$\ddot{x} + 2\zeta\omega_n\dot{x} + \omega_n^2 x = q \sin \omega t \quad (1.87)$$

where

$$\omega_n = \sqrt{\frac{k}{M}} \quad 2\zeta\omega_n = \frac{c}{M} \quad q = \frac{m\mu\omega^2}{M} \quad (1.88)$$

Hence, the steady state forced vibration are

$$x = A \sin(\omega t + \varphi) \quad (1.89)$$

where according to 1.77

$$A = \frac{\frac{q}{\omega_n^2}}{\sqrt{(1 - (\frac{\omega}{\omega_n})^2)^2 + 4\zeta^2(\frac{\omega}{\omega_n})^2}} \quad \varphi = -\arctan \frac{2\zeta\frac{\omega}{\omega_n}}{1 - (\frac{\omega}{\omega_n})^2} \quad (1.90)$$

or, taking into consideration 1.88

$$A = \frac{\frac{m}{M}\mu(\frac{\omega}{\omega_n})^2}{\sqrt{(1 - (\frac{\omega}{\omega_n})^2)^2 + 4\zeta^2(\frac{\omega}{\omega_n})^2}} \quad \varphi = -\arctan \frac{2\zeta\frac{\omega}{\omega_n}}{1 - (\frac{\omega}{\omega_n})^2} \quad (1.91)$$

The ratio $\frac{A}{\frac{m}{M}\mu}$, is called the magnification factor, Its magnitude and the phase φ as a function of the ratio $\frac{\omega}{\omega_n}$ for different damping factor ζ is shown in Fig. 29. If the frequency of excitation changes from zero to the value equal to the natural frequency ω_n , the amplitude of the forced vibration is growing. Its maximum depends on the damping ratio and appears for $\omega > \omega_n$. The phenomenon at which amplitude of the forced vibration is maximum is called *amplitude resonance*. If the frequency of excitation tends towards infinity, the amplitude of the forced vibration tends to $\frac{m}{M}\mu$. For $\omega = \omega_n$, regardless the damping involved, phase of the forced vibration is equal to 90° . This phenomenon is called *phase resonance*. If the frequency of excitation

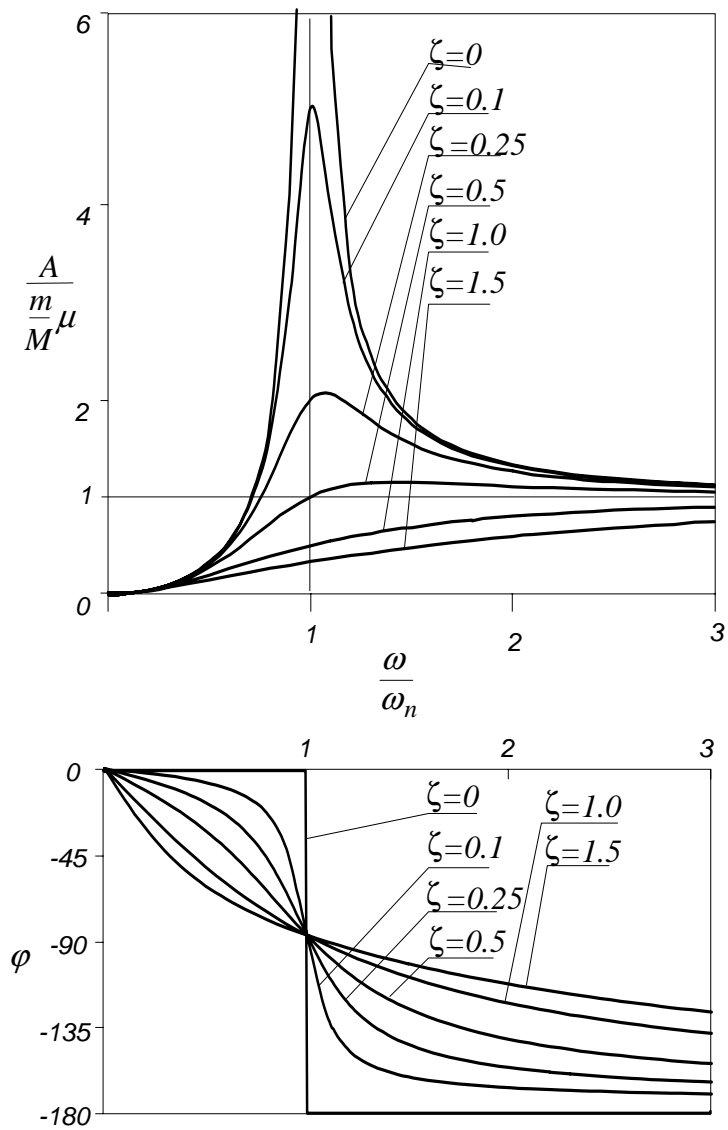

Figure 29

tends to infinity, the phase tends to 180° . Hence the response of the system tends to be in the anti-phase with the excitation.

The force transmitted to the foundation R , according to the physical model shown in Fig. 28b) is

$$R(t) = kx + c\dot{x} = kA \sin(\omega t + \varphi) + cA\omega \cos(\omega t + \varphi) = A\sqrt{k^2 + c^2\omega^2} \sin(\omega t + \varphi + \delta) \quad (1.92)$$

The amplitude of the reaction is

$$\begin{aligned} |R| &= A\sqrt{k^2 + c^2\omega^2} = AM\sqrt{\omega_n^4 + 4\zeta^2\omega_n^2\omega^2} = \\ &= m\mu\omega^2 \frac{\sqrt{1 + 4\zeta^2\left(\frac{\omega}{\omega_n}\right)^2}}{\sqrt{\left(1 - \left(\frac{\omega}{\omega_n}\right)^2\right)^2 + 4\zeta^2\left(\frac{\omega}{\omega_n}\right)^2}} \end{aligned}$$

The amplification ratio $\frac{|R|}{m\mu\omega^2}$ of the reaction as a function of the ratio $\frac{\omega}{\omega_n}$ is shown in Fig. 30. For the frequency of excitation $\omega < 1.4\omega_n$ the force transmitted to foundation

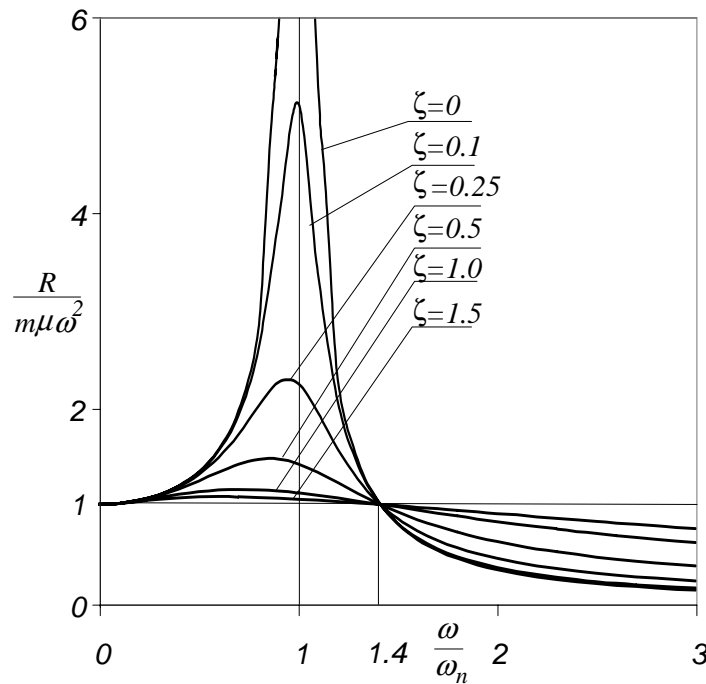

Figure 30

is greater than the centrifugal force itself with its maximum close to frequency ω_n . For $\omega > 1.4\omega_n$ this reaction is smaller than the excitation force and tends to zero when the frequency of excitation approaches infinity.

Forced response due to the kinematic excitation - vibration isolation

The physical model of a system with the kinematic excitation is shown in Fig. 31b). Motion of the point B along the axis y causes vibration of the block M . This physical

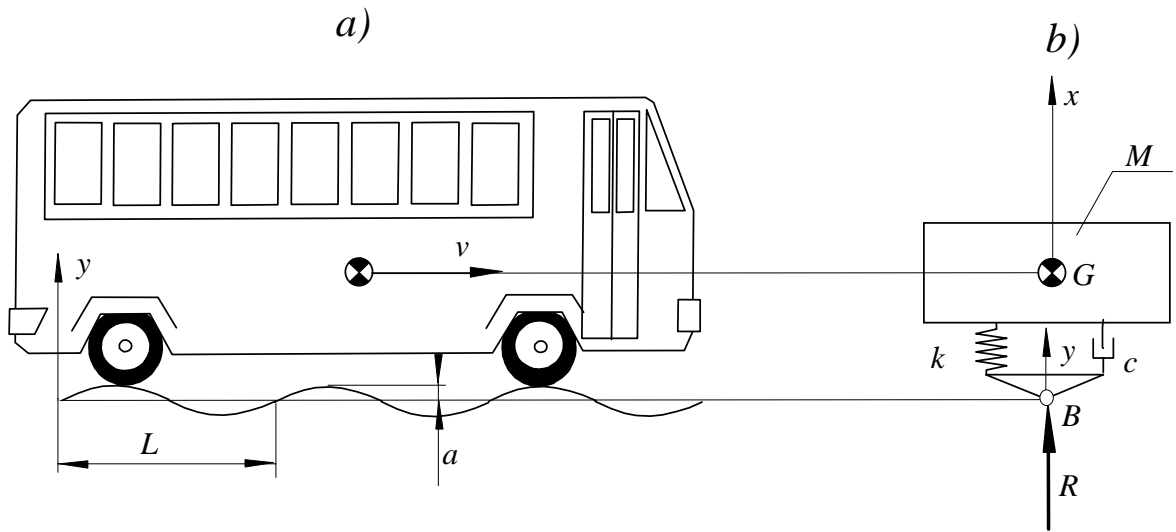

Figure 31

model can be used to analyze vibration of a bus caused by the roughness of the surface of the road shown in Fig. 31a). The stiffness k of the spring and the damping coefficient c represent the dynamic properties of the bus shock-absorbers. The block of mass M stands for the body of the bus. If the surface can be approximated by the sine-wave of the amplitude a and length L and the bus is travelling with the constant velocity v , the period of the harmonic excitation is

$$T = \frac{L}{v} \quad (1.93)$$

Hence, the frequency of excitation, according to 1.39 is

$$\omega = \frac{2\pi v}{L} \quad (1.94)$$

and the motion of the point B along the axis y can be approximated as follows

$$y = a \sin \omega t \quad (1.95)$$

The equation of motion of the bus is

$$M\ddot{x} = -kx - c\dot{x} + ky + cy \quad (1.96)$$

Introduction of 1.95 yields

$$M\ddot{x} + c\dot{x} + kx = ka \sin \omega t + ca\omega \cos \omega t$$

or

$$\ddot{x} + 2\zeta\omega_n\dot{x} + \omega_n^2x = \omega_n^2a \sin \omega t + 2\zeta\omega_n\omega a \cos \omega t = q \sin(\omega t + \alpha) \quad (1.97)$$

where

$$q = a\omega_n^2 \sqrt{1 + 4\zeta^2 \left(\frac{\omega}{\omega_n}\right)^2} \quad (1.98)$$

Without any harm to the generality of the considerations one can neglect the phase α and adopt the mathematical model in the following form

$$\ddot{x} + 2\zeta\omega_n\dot{x} + \omega_n^2x = q \sin \omega t \quad (1.99)$$

Motion of the block along axis x is governed by the equation 1.83

$$x = A \sin(\omega t + \varphi)$$

where

$$A = \frac{\frac{q}{\omega_n^2}}{\sqrt{(1 - (\frac{\omega}{\omega_n})^2)^2 + 4\zeta^2(\frac{\omega}{\omega_n})^2}} \quad \varphi = -\arctan \frac{2\zeta\frac{\omega}{\omega_n}}{1 - (\frac{\omega}{\omega_n})^2} \quad (1.100)$$

Introduction of equation 1.98 gives

$$A = \frac{a\sqrt{1 + 4\zeta^2(\frac{\omega}{\omega_n})^2}}{\sqrt{(1 - (\frac{\omega}{\omega_n})^2)^2 + 4\zeta^2(\frac{\omega}{\omega_n})^2}} \quad \varphi = -\arctan \frac{2\zeta\frac{\omega}{\omega_n}}{1 - (\frac{\omega}{\omega_n})^2} \quad (1.101)$$

The magnifying factor $\frac{A}{a}$ and the phase φ as a function of $\frac{\omega}{\omega_n}$ is shown in Fig. 32. For $\omega < 1.4\omega_n$ it is possible to arrange for the bus to have vibration smaller than the amplitude of the kinematic excitation

The expression for the reaction force transmitted to the foundation is

$$\begin{aligned} R &= kx + c\dot{x} - ky - c\dot{y} = kA \sin(\omega t + \varphi) + c\omega A \cos(\omega t + \varphi) - ka \sin \omega t - c\omega a \cos \omega t \\ &= |R| \sin(\omega t + \gamma) \end{aligned} \quad (1.102)$$

Problem of minimizing the reaction force R (e.g. 1.92) or the amplitude A (e.g. 1.101) is called *vibration isolation*.

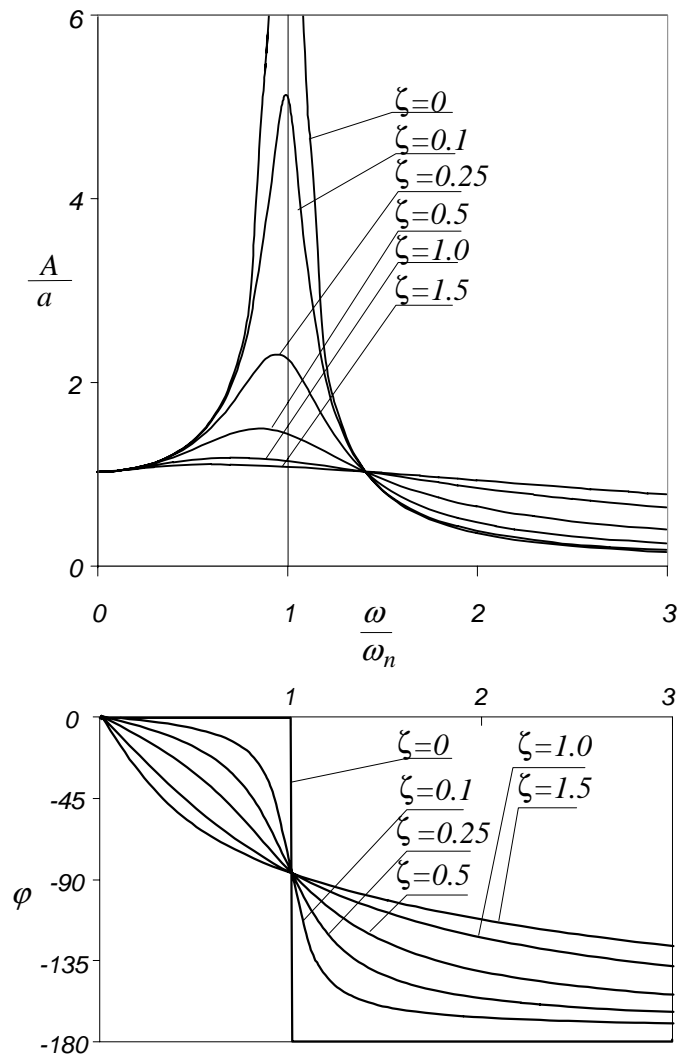

Figure 32

1.2.3 Problems

Free vibrations

Problem 9

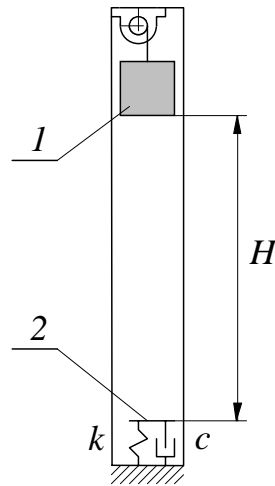

Figure 33

The carriage 1 of the lift shown in Fig. 33 operates between floors of a building. The distance between the highest and the lowest floor is $H = 30m$. The average mass of the carriage is $m = 500kg$. To attenuate the impact between the carriage and the basement in the case the rope 3 is broken, the shock absorber 2 is to be installed.

Calculate the stiffness k and the damping coefficient c of the shock-absorber which assure that the deceleration during the impact is smaller than $200m/s^2$.

Solution

In the worst case scenario, the lift is at the level H when the rope brakes.

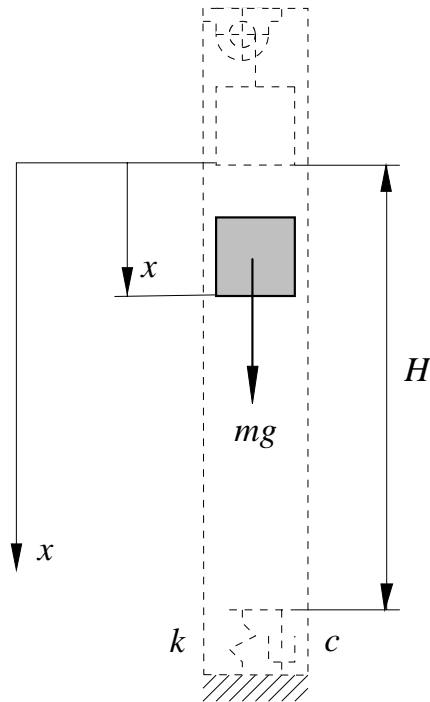

Figure 34

Due to the gravity force the lift is falling down with the initial velocity equal to zero. Equation of motion of the lift is

$$m\ddot{x} = mg \quad (1.103)$$

By double side by side integrating of the above equation one can get

$$x = A + Bt + \frac{g}{2}t^2 \quad (1.104)$$

Introduction of the following initial conditions

$$x|_{t=0} = 0 \quad \dot{x}|_{t=0} = 0$$

yields $A = 0$ and $B = 0$ and results in the following equation of motion

$$x = \frac{g}{2}t^2 \quad (1.105)$$

Hence, the time the lift reaches the shock-absorber is

$$t_o = \sqrt{\frac{2H}{g}} \quad (1.106)$$

Since

$$v = \dot{x} = gt \quad (1.107)$$

the velocity of the lift at the time of the impact with the shock-absorber is

$$v_o = \dot{x} \big|_{t=t_o} = \sqrt{2Hg} \quad (1.108)$$

To analyze the motion of the lift after impact let us introduce the inertial axis y in such a way that its origin coincides with the upper end of the shock-absorber at the instant of impact (see Fig. 35). Since at the instant of impact the spring k is

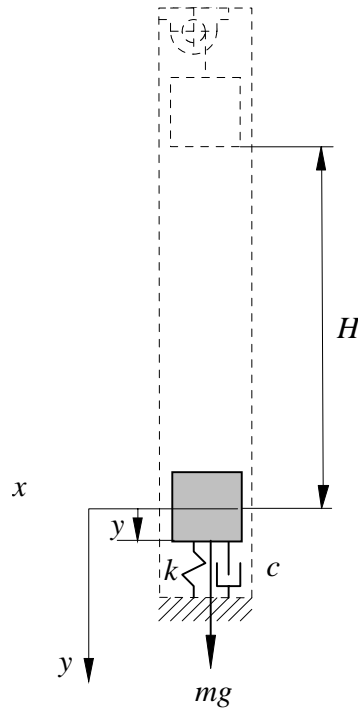

Figure 35

uncompressed, the equation of motion after the lift has reached the shock-absorber is

$$m\ddot{y} + c\dot{y} + ky = mg \quad (1.109)$$

or in the standardized form

$$\ddot{y} + 2\zeta\omega_n\dot{y} + \omega_n^2y = g \quad (1.110)$$

where

$$\omega_n = \sqrt{\frac{k}{m}}; \quad 2\zeta\omega_n = \frac{c}{m} \quad (1.111)$$

It is easy to see that in the case considered the particular solution of the non-homogeneous equation is

$$y_p = \frac{g}{\omega_n^2} \quad (1.112)$$

The best performance of the shock-absorber is expected if the damping is critical ($\zeta = 1$). In this case, there exists one double root and the general solution of the homogeneous equation is

$$y_g = C_1e^{-\omega_n t} + C_2te^{-\omega_n t} \quad (1.113)$$

Therefore the general solution of the non-homogeneous equation as the sum of y_p and y_g is

$$y = C_1 e^{-\omega_n t} + C_2 t e^{-\omega_n t} + \frac{g}{\omega_n^2} \quad (1.114)$$

This equation has to fulfill the following initial conditions

$$y|_{t=0} = 0 \quad \dot{y}|_{t=0} = v_o \quad (1.115)$$

Introduction of these initial conditions into the equation 1.113 yields

$$C_1 = -\frac{g}{\omega_n^2} \quad C_2 = v_o - \frac{g}{\omega_n} \quad (1.116)$$

and results in the following equation of motion

$$\begin{aligned} y &= \left(-\frac{g}{\omega_n^2}\right) e^{-\omega_n t} + \left(v_o - \frac{g}{\omega_n}\right) t e^{-\omega_n t} + \frac{g}{\omega_n^2} \\ &= \frac{g}{\omega_n^2} (1 - e^{-\omega_n t}) + \left(v_o - \frac{g}{\omega_n}\right) t e^{-\omega_n t} = D (1 - e^{-\omega_n t}) + E t e^{-\omega_n t} \end{aligned} \quad (1.117)$$

where

$$D = \frac{g}{\omega_n^2} \quad E = v_o - \frac{g}{\omega_n} \quad (1.118)$$

Double differentiation of the function 1.117 yields acceleration during the impact

$$\ddot{y} = (-D\omega_n^2 - 2E\omega_n) e^{-\omega_n t} + E\omega_n^2 t e^{-\omega_n t} \quad (1.119)$$

By inspection of the function 1.118, one can see that the maximum of the deceleration occurs for time $t = 0$. Hence the maximum of deceleration is

$$a_{max} = \ddot{y}|_{t=0} = |-D\omega_n^2 - 2E\omega_n| \quad (1.120)$$

If

$$v_o > \frac{g}{\omega_n} \quad (1.121)$$

both constants E and D are positive. Hence

$$a_{max} = D\omega_n^2 + 2E\omega_n = g + 2v_o\omega_n - 2g = 2v_o\omega_n - g \quad (1.122)$$

This deceleration has to be smaller than the allowed deceleration $a_a = 200ms^{-2}$.

$$2v_o\omega_n - g < a_a \quad (1.123)$$

It follows

$$\omega_n < \frac{a_a + g}{2\sqrt{2Hg}} = \frac{200 + 10}{2\sqrt{2 \cdot 30 \cdot 10}} = 4.28s^{-1} \quad (1.124)$$

Since $\omega_n = \sqrt{\frac{k}{m}}$, the stiffness of the shock-absorber is

$$k = \omega_n^2 m = 4.28^2 \cdot 500 = 9160N/m \quad (1.125)$$

and the damping coefficient

$$c = 2\zeta\omega_n m = 2 \cdot 1 \cdot 4.28 \cdot 500 = 4280 \text{Ns/m} \quad (1.126)$$

Our computation can be accepted only if the inequality 1.121 is fulfilled. Indeed

$$v_o = \sqrt{2Hg} = \sqrt{2 \cdot 30 \cdot 10} = 24.5 > \frac{g}{\omega_n} = \frac{10}{4.28} = 2.4 \text{m/s} \quad (1.127)$$

The displacement of the lift, its velocity and acceleration during the impact as a function of time is shown in Fig. 36

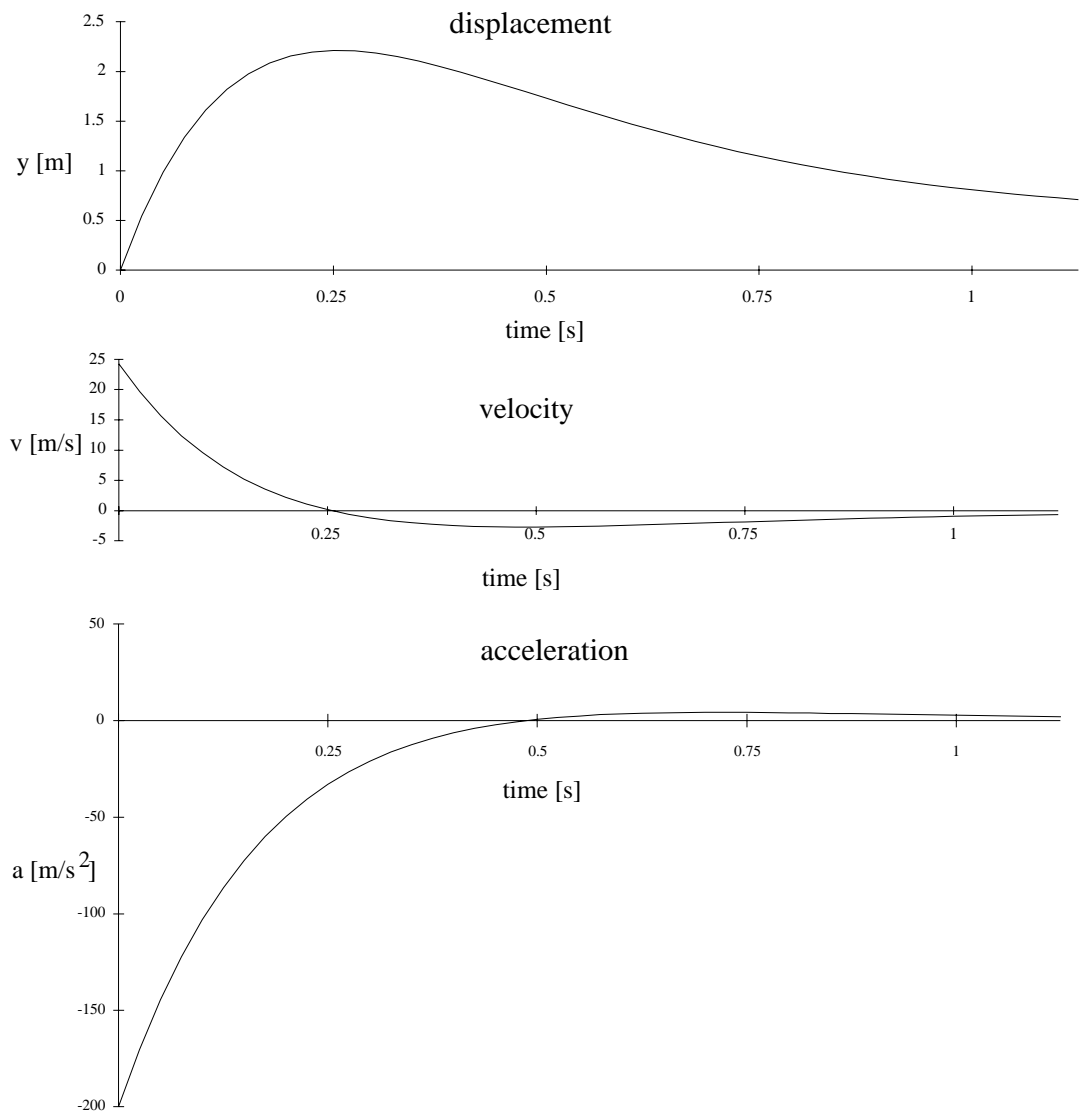

Figure 36

Problem 10

The power winch W was mounted on the truss T as shown in Fig. 37a) To

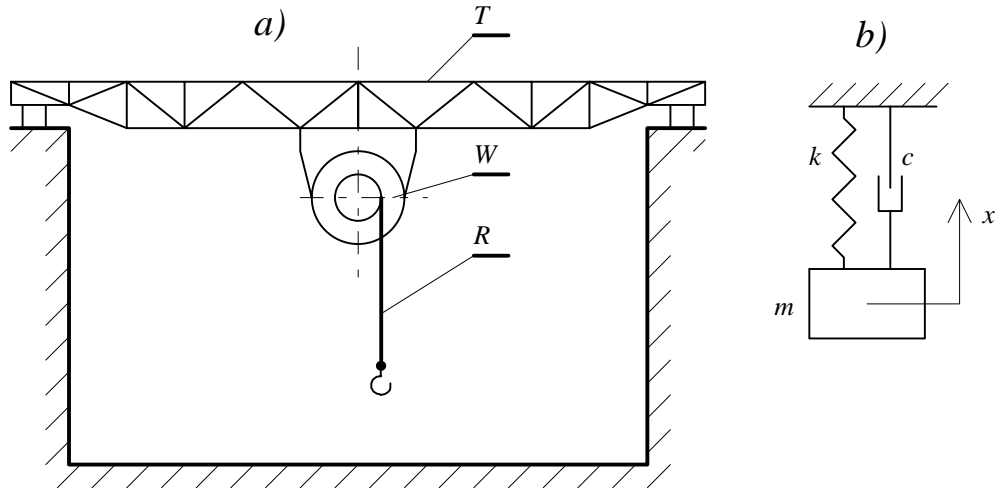

Figure 37

analyze the vibrations of the power winch the installation was modelled by the one degree of freedom physical model shown in Fig. 38b). In this figure the equivalent mass, stiffness and damping coefficient are denoted by m , k and c respectively. Origin of the axis x coincides with the centre of gravity of the weight m when the system rests in its equilibrium position.

To identify the unknown parameters m , k , and c , the following experiment was carried out. The winch was loaded with the weight equal to $M_1 = 1000\text{kg}$ as shown in Fig. 38. Then the load was released allowing the installation to perform the vertical

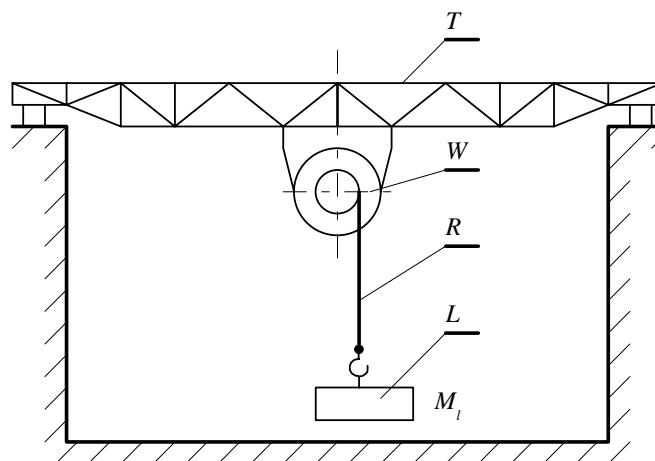

Figure 38

oscillations in x direction. Record of those oscillations is presented in Fig. 39.

Calculate the parameters m , k , and c .

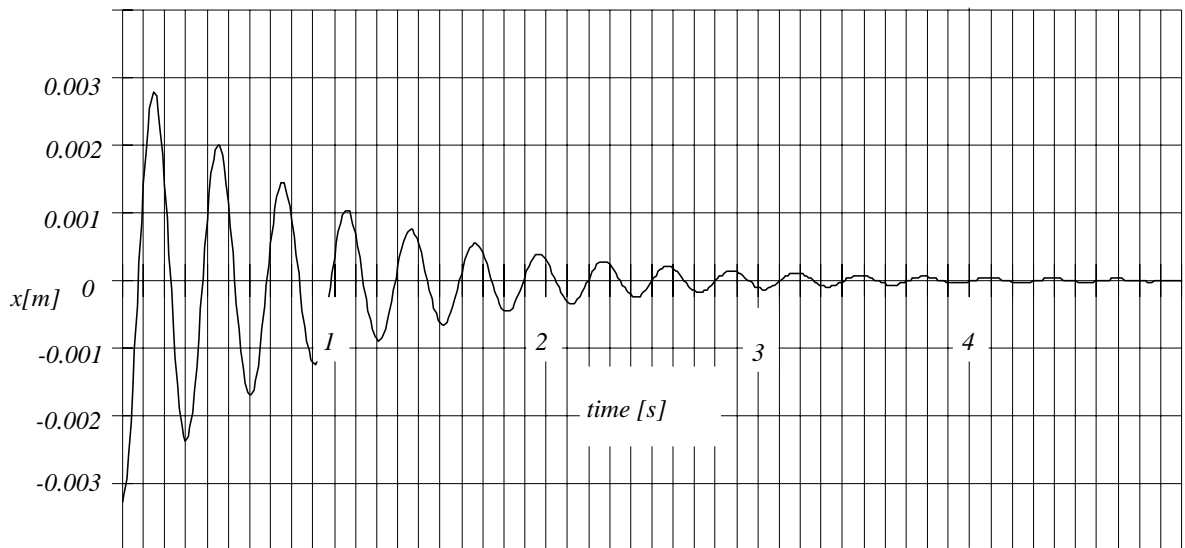

Figure 39

Answer

$$m = 7000kg; \quad k = 3000000Nm^{-1}; \quad c = 15000Nsm^{-1}$$

Problem 11

Figure 40

The winch W shown in Fig. 40 is modelled as a system with one degree of freedom of mass m stiffness k and the damping coefficient c . The winch is lifting the block of mass M with the constant velocity v_o (see Fig. 41). Assuming that the rope

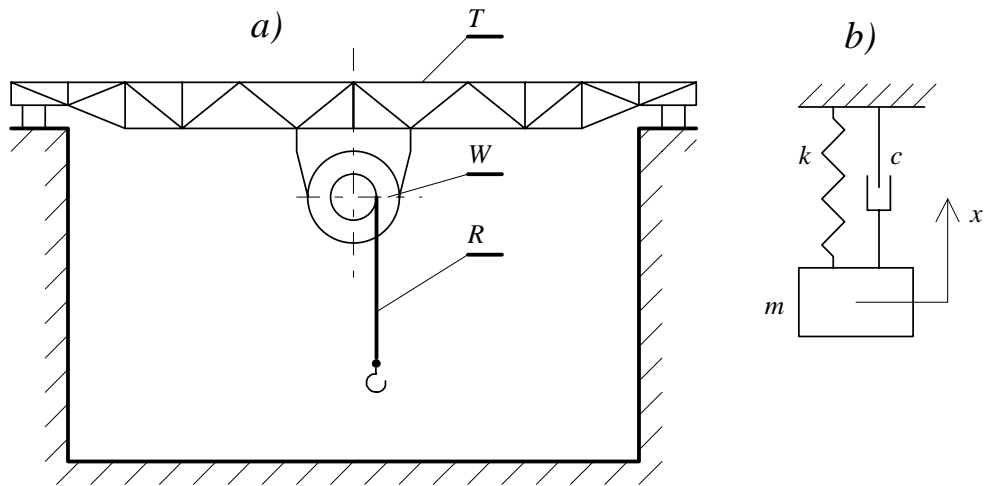
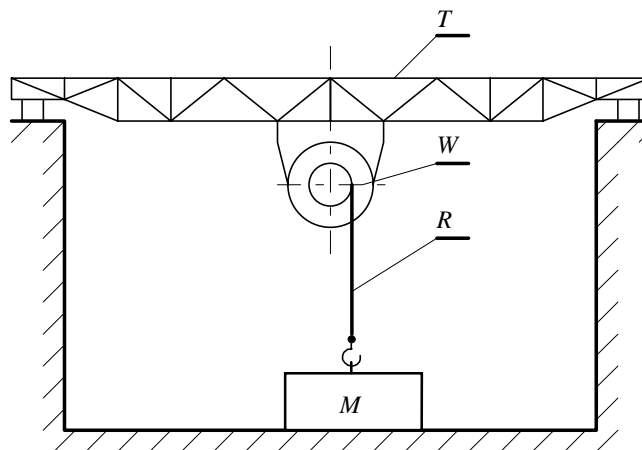

Figure 41

R is not extendible produce expression for the tension in the rope R before and after the block will lose contact with the floor.

Solution

Tension in the rope R before the contact is lost

In the first stage of lifting the block M , it stays motionlessly at the floor whereas the lift itself is going down with respect to the inertial axis x with the constant velocity v_o . The tension T in the rope R varies between 0 and Mg .

$$0 < T \leq Mg \quad (1.128)$$

If origin of the inertial axis x coincides with the gravity centre when the unloaded winch is at its equilibrium, the equation of motion of the winch is

$$m\ddot{x} + c\dot{x} + kx = -T \quad (1.129)$$

In the above equation $\ddot{x} = 0$ (the winch is moving with the constant velocity v_o), $\dot{x} = -v_o$ and $x = -v_o t$. Hence

$$-T = c(-v_o) + k(-v_o t) \quad (1.130)$$

The equation 1.130 governs motion of the winch till the tension T will reach value Mg . Therefore the equation 1.130 allows the time of separation t_s to be obtained.

$$t_s = \frac{Mg - cv_o}{kv_o} \quad (1.131)$$

At the instant of separation the winch will be at the position determined by the following formula

$$x_s = -v_o t_s = -\frac{Mg - cv_o}{k} \quad (1.132)$$

If $Mg < cv_o$ then $x_s = t_s = 0$.

If $Mg > cv_o$

$$T = cv_o + kv_o t \quad \text{for} \quad 0 < t < t_s \quad (1.133)$$

Tension in the rope R after the contact of the weight with the floor is lost

Without any harm to the generality of the further consideration one may assume that the time corresponding to the instant of separation is equal to 0.

For $t > 0$, the equation of motion of the winch and the block (see Fig. 42) are as following

$$\begin{aligned} m\ddot{x} + c\dot{x} + kx &= -T \\ M\ddot{x}_b &= T - Mg \end{aligned} \quad (1.134)$$

Since the rope R is not extendible, the instantaneous length of the rope L is

$$L = L_o - v_o t \quad (1.135)$$

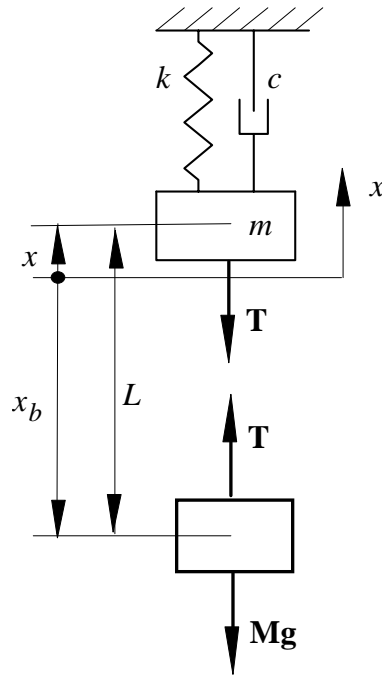

Figure 42

Where L_o stands for the initial length of the rope (the length the rope had at the instance $t = 0$). Taking into account that

$$L = x - x_b \quad (1.136)$$

we have

$$x_b = x - L = x - L_o + v_o t \quad (1.137)$$

Introduction of the equation 1.137 into 1.134 yields

$$\begin{aligned} m\ddot{x} + c\dot{x} + kx &= -T \\ M\ddot{x} &= T - Mg \end{aligned} \quad (1.138)$$

Elimination of the unknown tension force allows the equation of motion of the winch to be formulated

$$(m + M)\ddot{x} + c\dot{x} + kx = -Mg \quad (1.139)$$

The standardized form is as following

$$\ddot{x} + 2\zeta\omega_n\dot{x} + \omega_n^2x = q \quad (1.140)$$

where

$$\omega_n = \sqrt{\frac{k}{m + M}}; \quad 2\zeta\omega_n = \frac{c}{m + M}; \quad q = -\frac{Mg}{m + M} \quad (1.141)$$

The particular solution of the non-homogeneous equation can be predicted as a constant magnitude A . Hence

$$\omega_n^2 A = q; \quad A = \frac{q}{\omega_n^2} \quad (1.142)$$

The general solution of the mathematical model 1.140 is

$$x = e^{-\zeta\omega_n t} (C_s \sin \omega_d t + C_c \cos \omega_d t) + A \quad (1.143)$$

where

$$\omega_d = \omega_n \sqrt{1 - \zeta^2} \quad (1.144)$$

This solution has to fulfill the following initial conditions

$$\text{for } t = 0 \quad x = x_s \quad \dot{x} = -v_o \quad (1.145)$$

Introduction of these initial conditions into the solution 1.143 yields the following expressions for the constants C_s and C_c

$$C_s = \frac{-v_o + \zeta\omega_n(x_s - A)}{\omega_d} \quad C_c = x_s - A \quad (1.146)$$

Hence,

$$x = e^{-\zeta\omega_n t} \left(\frac{-v_o + \zeta\omega_n(x_s - A)}{\omega_d} \sin \omega_d t + (x_s - A) \cos \omega_d t \right) + A \quad (1.147)$$

The time history diagram of the above function is shown in Fig.43 The tension is

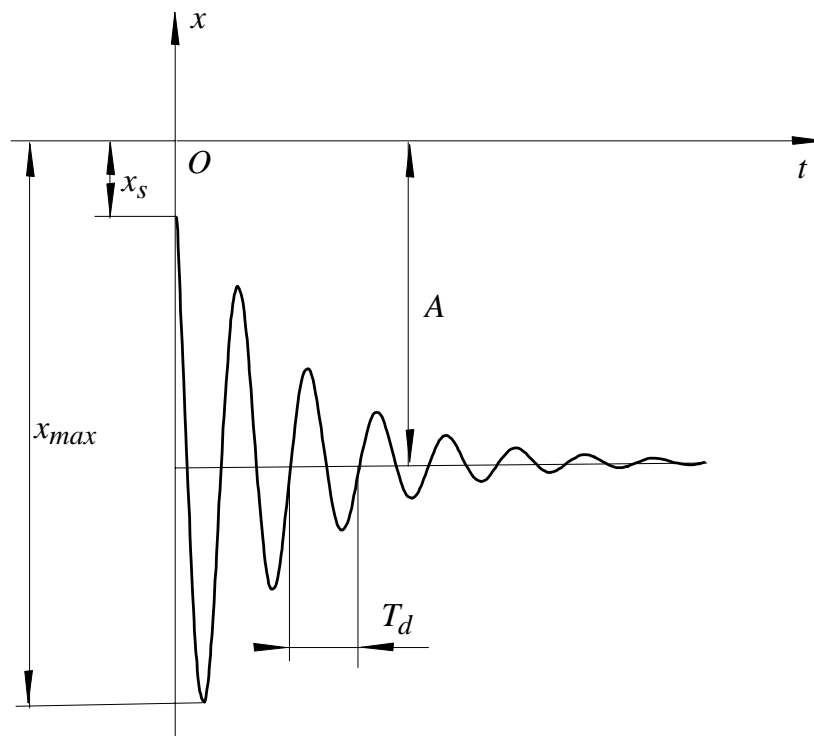

Figure 43

determined by the equation 1.138

$$T = M\ddot{x} + Mg \quad (1.148)$$

Double differentiation of the function 1.147 yields the wanted tension as a function of time

$$\begin{aligned} T = & Mg + Me^{-\zeta\omega_n t} (C_s(\zeta\omega_n)^2 + 2C_c\zeta\omega_n\omega_d - C_s\omega_d^2) \sin \omega_d t \\ & + Me^{-\zeta\omega_n t} (C_c(\zeta\omega_n)^2 - 2C_s\zeta\omega_n\omega_d + C_c\omega_d^2) \cos \omega_d t \end{aligned} \quad (1.149)$$

Forced vibration

Problem 12

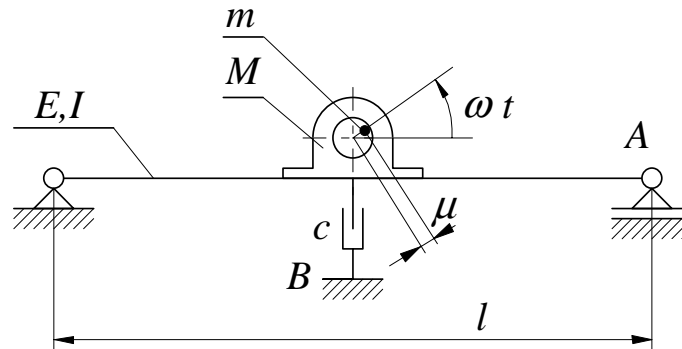

Figure 44

The electric motor of mass M (see Fig. 44) is mounted on the massless beam of length l , the second moment of inertia of its cross-section I and Young modulus E . Shaft of the motor, of mass m , rotates with the constant angular velocity ω and its unbalance (distance between the axis of rotation and the shaft centre of gravity) is μ . The damping properties of the system are modelled by the linear damping of the damping coefficient c . Produce expression for the amplitude of the forced vibration of the motor as well as the interaction forces transmitted to the foundation at the points A and B .

Solution

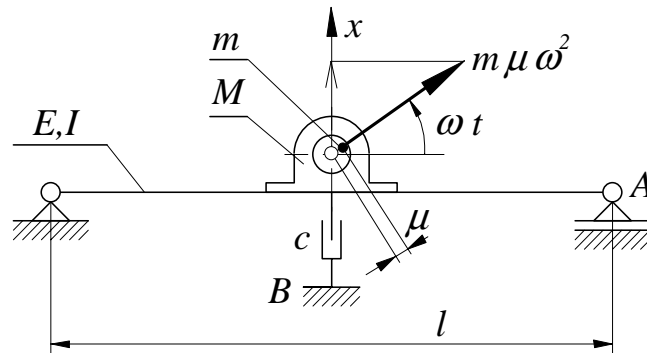

Figure 45

Application of the Newton's approach to the system shown in Fig. 45 results in the following differential equations of motion.

$$M\ddot{x} = -kx - c\dot{x} + m\mu\omega^2 \sin \omega t \quad (1.150)$$

where k stands for the stiffness of the beam EI .

$$k = \frac{48EI}{l^3} \quad (1.151)$$

Its standardized form is

$$\ddot{x} + 2\zeta\omega_n\dot{x} + \omega_n^2x = q \sin \omega t \quad (1.152)$$

where

$$\omega_n = \sqrt{\frac{k}{M}} \quad 2\zeta\omega_n = \frac{c}{m+M} \quad q = \frac{m\mu\omega^2}{M} \quad (1.153)$$

The particular solution of the equation 1.152

$$x = A \sin(\omega t + \varphi) \quad (1.154)$$

where

$$A = \frac{\frac{q}{\omega_n^2}}{\sqrt{(1 - (\frac{\omega}{\omega_n})^2)^2 + 4\zeta^2(\frac{\omega}{\omega_n})^2}} \quad \varphi = -\arctan \frac{2\zeta\frac{\omega}{\omega_n}}{1 - (\frac{\omega}{\omega_n})^2} \quad (1.155)$$

represents the forced vibrations of the system. In the above formula A stands for the amplitude of the forced vibrations of the motor. The interaction force at the point A can be determined from equilibrium of forces acting on the beam at an arbitrarily chosen position x (see Fig 46).

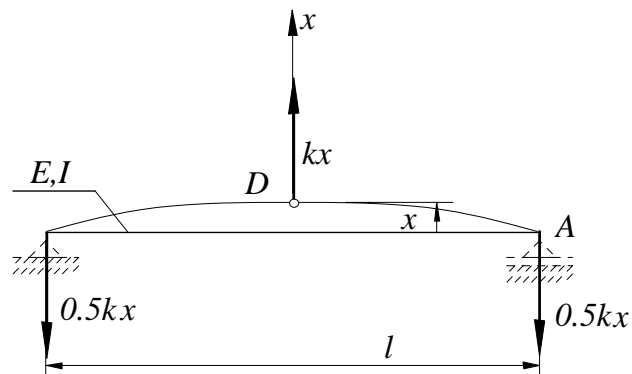

Figure 46

The force needed to displace the point D by x is equal to kx . Hence, the reaction at the point A is

$$R_A = -0.5kx = -0.5kA \sin(\omega t + \varphi) \quad (1.156)$$

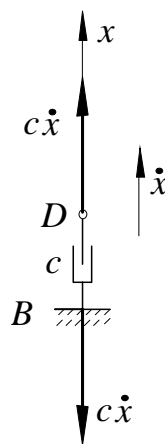

Figure 47

To move the point D (see Fig. 47) with the velocity \dot{x} the force $c\dot{x}$ is required. Hence, from the equilibrium of the damper one can see that the reaction at the point B is

$$R_B = -c\dot{x} = -c\omega A \sin(\omega t + \varphi)$$

Problem 13

Figure 48

Figure 48 presents a seismic transducer. Its base 2 is attached to the vibrating object 1. The seismic weight 3 of mass m is supported by the spring 4 of stiffness k and the damper 5 of the damping coefficient c . This transducer records the displacement

$$z = x - y \quad (1.157)$$

where y is the absolute displacement of the vibration object 1 and x is the absolute displacement of the seismic weight 3. Upon assuming that the object 1 performs a harmonic motion

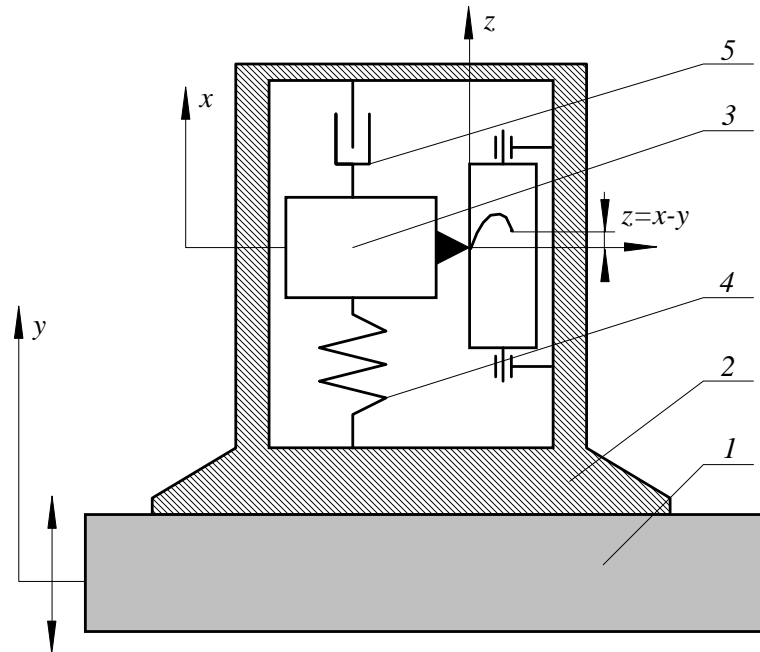
$$y = a \sin \omega t \quad (1.158)$$

derive the formula for the amplification coefficient \varkappa of the amplitude of vibration of the object 1 of this transducer ($\varkappa = \frac{\text{amplitude of } z}{\text{amplitude of } y}$) as a function of the non-dimensional frequency $\frac{\omega}{\omega_n}$.

Solution

The equation of motion of the system shown in Fig. 48 is

$$m\ddot{x} + c\dot{x} + kx = cy + ky \quad (1.159)$$

Its standardize form is

$$\ddot{x} + 2\zeta\omega_n\dot{x} + \omega_n^2x = aq_c \cos \omega t + aq_s \sin \omega t \quad (1.160)$$

where

$$\omega_n = \sqrt{\frac{k}{m}} \quad 2\zeta\omega_n = \frac{c}{m} \quad q_c = \frac{c}{m}\omega \quad q_s = \frac{k}{m} \quad (1.161)$$

Simplification of the right side of the above equation yields

$$\ddot{x} + 2\zeta\omega_n\dot{x} + \omega_n^2x = aq \sin(\omega t + \alpha) \quad (1.162)$$

where

$$q = \sqrt{q_c^2 + q_s^2} = \omega_n^2 \sqrt{4\zeta^2 \left(\frac{\omega}{\omega_n}\right)^2 + 1} \quad \alpha = \arctan \frac{q_c}{q_s} = \arctan 2\zeta \frac{\omega}{\omega_n} \quad (1.163)$$

According to equation 1.76 (page 35) the particular solution of the equation 1.162 is

$$x_p = aA \sin(\omega t + \alpha + \varphi) \quad (1.164)$$

where

$$A = \frac{\sqrt{4\zeta^2 \left(\frac{\omega}{\omega_n}\right)^2 + 1}}{\sqrt{\left(1 - \left(\frac{\omega}{\omega_n}\right)^2\right)^2 + 4\zeta^2 \left(\frac{\omega}{\omega_n}\right)^2}} \quad \varphi = -\arctan \frac{2\zeta \frac{\omega}{\omega_n}}{1 - \left(\frac{\omega}{\omega_n}\right)^2} \quad (1.165)$$

Hence the record of the transducer is

$$\begin{aligned} z &= x - y = aA \sin(\omega t + \alpha + \varphi) - a \sin \omega t = \\ &= aA \cos(\alpha + \varphi) \sin \omega t + aA \sin(\alpha + \varphi) \cos \omega t - a \sin \omega t = \\ &= (aA \cos(\alpha + \varphi) - a) \sin \omega t + aA \sin(\alpha + \varphi) \cos \omega t \end{aligned} \quad (1.166)$$

The amplitude of this record is

$$amp_z = \sqrt{(aA \cos(\alpha + \varphi) - a)^2 + (aA \sin(\alpha + \varphi))^2} = a\sqrt{A^2 + 1 - 2A \cos(\alpha + \varphi)} \quad (1.167)$$

Therefore, the coefficient of amplification is

$$\varkappa = \frac{amp_z}{amp_y} = \sqrt{A^2 + 1 - 2A \cos(\alpha + \varphi)} \quad (1.168)$$

The diagram presented in Fig.49 shows this amplification coefficient \varkappa as a function of the ratio $\frac{\omega}{\omega_n}$. If the coefficient of amplification \varkappa is equal to one, the record of the

amplitude of vibration (amp_z) is equal to the amplitude of vibration of the object ($amp_y = a$). It almost happens, as one can see from the diagram 49, if the frequency ω of the recorded vibrations is twice greater than the natural frequency ω_n of the transducer and the damping ratio ζ is 0.25.

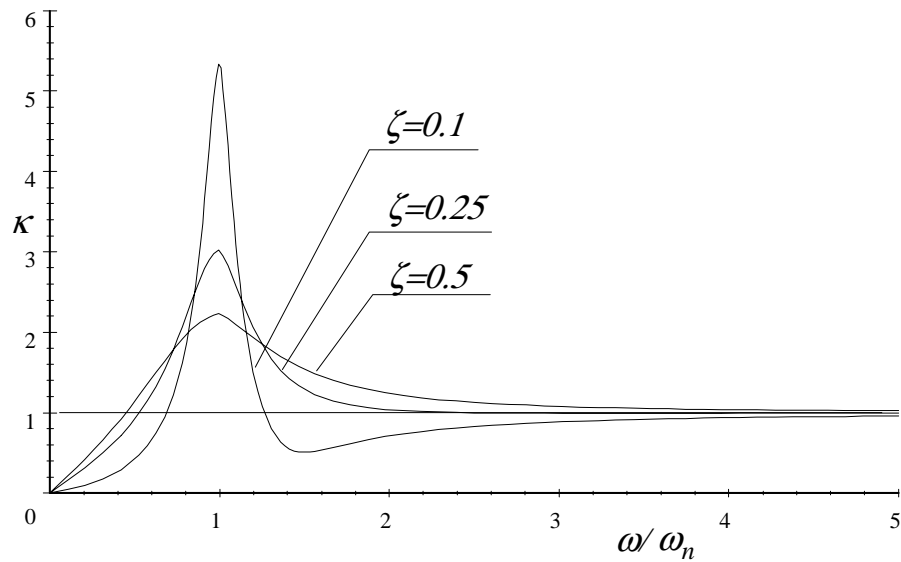

Figure 49

Problem 14

Figure 50

The physical model of a vibrating table is shown in Fig. 50. It can be considered as a rigid body of the mass m and the moment of inertia about axis through its centre of gravity I_G . It is supported with by means of the spring of the stiffness k and the damper of the damping coefficient c . The motion of the lower end of the spring with respect to the absolute coordinate x can be approximated as follows

$$x = X \cos \omega t$$

where X stands for the amplitude of the oscillations of the point C and ω stands for the frequency of these oscillations.

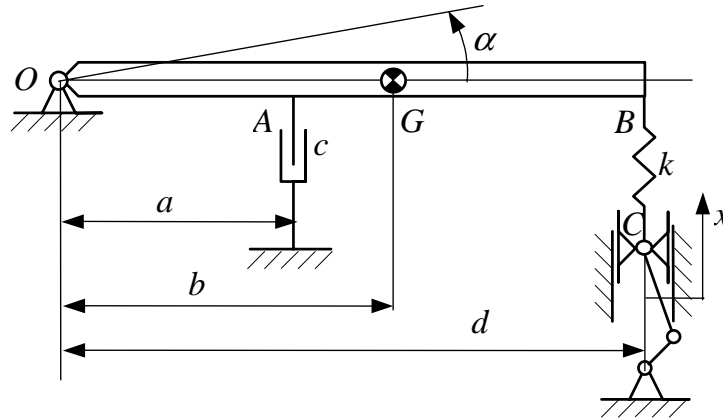
Produce:

1. the differential equation of motion of the vibrating table and present it in the standard form
2. the expression for the amplitude of the forced vibrations of the table caused by the motion of the point C
3. the expression for the interaction force at the point A
4. the expression for the driving force that has to be applied to the point C

Problem 15

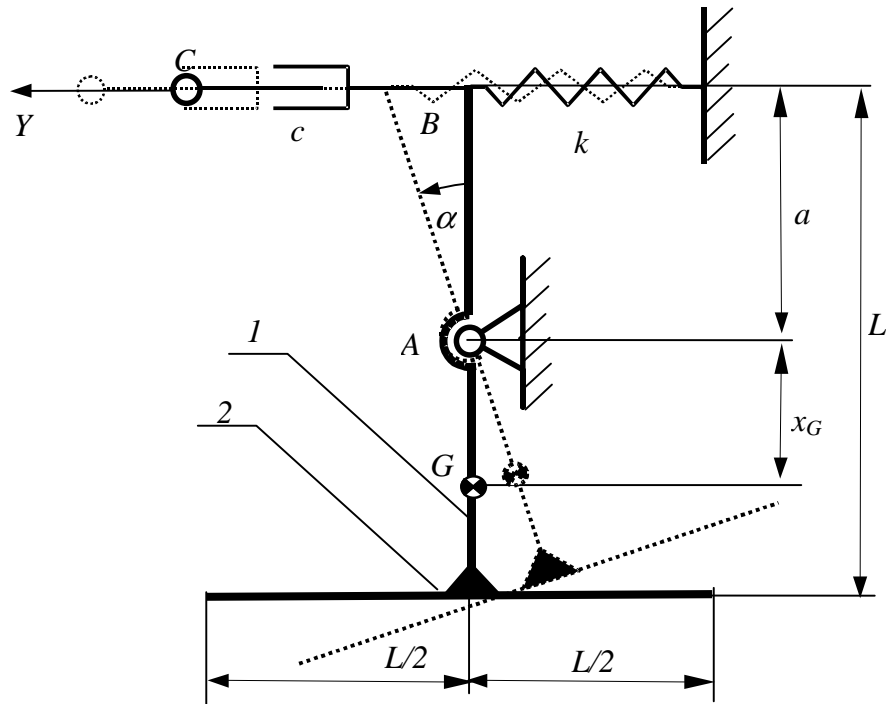

Figure 51

Two uniform rods (1 and 2), each of length L and mass m , were joined together to form the pendulum whose physical model is depicted in Fig. 51. The pendulum performs small oscillations α about the axis through the point A . At the point B it is supported by a spring of stiffness k and a damper of damping coefficient c . The point C of the damper is driven along the axis Y and its motion is approximated by the following function

$$Y = A \sin \omega t$$

Produce:

1. The expression for the position x_G of the center of gravity G of the pendulum

Answer:

$$x_G = \frac{3}{4}L - a$$

2. The expression for the moment of inertia of the pendulum about the axis through the point A .

Answer:

$$I_A = \frac{17}{12}mL^2 + 2maH2 - 3mLa$$

3. The differential equation of motion of the pendulum

Answer:

$$\ddot{\alpha} + 2\zeta\omega_n\dot{\alpha} + \omega_n^2\alpha = q \cos \omega t$$

where: $2\zeta\omega_n = \frac{ca^2}{I_A}$; $\omega_n^2 = \frac{2mgx_G + ka^2}{I_A}$ $q = \frac{A\omega ca}{I_A}$

4. The expression for the amplitude of the forced vibrations of the pendulum

Answer:

$$A_\alpha = \frac{\frac{q}{\omega_n^2}}{\sqrt{\left[1 - \left(\frac{\omega}{\omega_n}\right)^2\right]^2 + 4\zeta^2 \left(\frac{\omega}{\omega_n}\right)^2}}$$

5. The driving force that must be applied to the point C to assure the assumed motion .

$$D = c(A\omega \cos \omega t - aA_\alpha \cos(\omega t + \varphi)) \quad \varphi = -\arctan \frac{2\zeta \frac{\omega}{\omega_n}}{1 - \left(\frac{\omega}{\omega_n}\right)^2}$$

Chapter 2

MECHANICAL VIBRATION OF MULTI-DEGREE-OF-FREEDOM LINEAR SYSTEMS

Since in the nature massless or rigid elements do not exist, therefore each of the particle the real element is made of can moves independently. It follows that to determine its position with respect to the inertial space one has to introduce infinite number of coordinates. Hence, according to the previously introduce definition, the number of degrees of freedom of each real element is equal to infinity. But in many vibration problems, with acceptable accuracy, the real elements can be represented by a limited number of rigid elements connected to each other by means of massless elements representing the elastic and damping properties. This process is called *discretization* and the final result of this process is called *multi-degree-of-freedom system*. In this chapter it will be assumed that forces produced by these massless

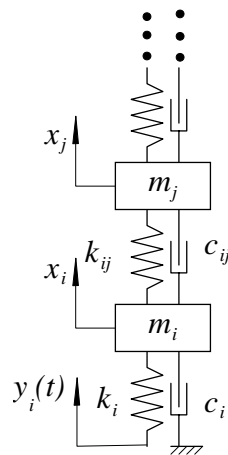

Figure 1

elements (springs and dampers) are linear functions of displacements and velocities respectively.

2.1 MODELLING

2.1.1 Physical model

Fig. 1 shows part of a multi-degree-of-freedom system. Usually, to describe motion of such a system a set of local generalized coordinates is introduced. These coordinates $(x_i, x_j, y_i(t))$ are motionless with respect to a global (inertial) system of coordinates

(not shown in the Fig. 1). The coordinate $y_i(t)$ is not independent (is an explicit function of time) whereas the coordinates x_i , and x_j are independent and their number determines the number of degree of freedom of the system. Origin of each coordinate coincides with the centre of gravity of individual bodies when the whole system is at its equilibrium position. For this equilibrium position all the static forces acting on individual bodies produces the resultant force equal to zero.

2.1.2 *Mathematical model*

It will be shown in this section that the equation of motion of the multi-degree of freedom linear system has the following form

$$\mathbf{m}\ddot{\mathbf{x}} + \mathbf{c}\dot{\mathbf{x}} + \mathbf{k}\mathbf{x} = \mathbf{F}(t)$$

where

\mathbf{m} - is the inertia matrix

\mathbf{c} - is the damping matrix

\mathbf{k} - is the stiffness matrix

\mathbf{F} - is the external excitation matrix

\mathbf{x} - is the displacement matrix

There are many methods that allow the mathematical model to be formulated.

In the following sections a few of them are presented.

Newton-Euler method of formulation of the mathematical model

To develop the equations of motion of the system described, one may utilize the Newton's or Euler's equations. Since in case considered the body of mass m_i performs a plane motion hence the Newton's equations may be used.

$$m_i \ddot{x}_i = F \tag{2.1}$$

If the system stays at its equilibrium position, as it was mention earlier, the resultant of all static forces is equal zero. Therefore, the force F must contains forces due to the displacement of the system from its equilibrium position only. To figure these forces out let us move the mass m_i out of its equilibrium position by the displacement x_i . The configuration *a*) shown in the figure below is achieved.

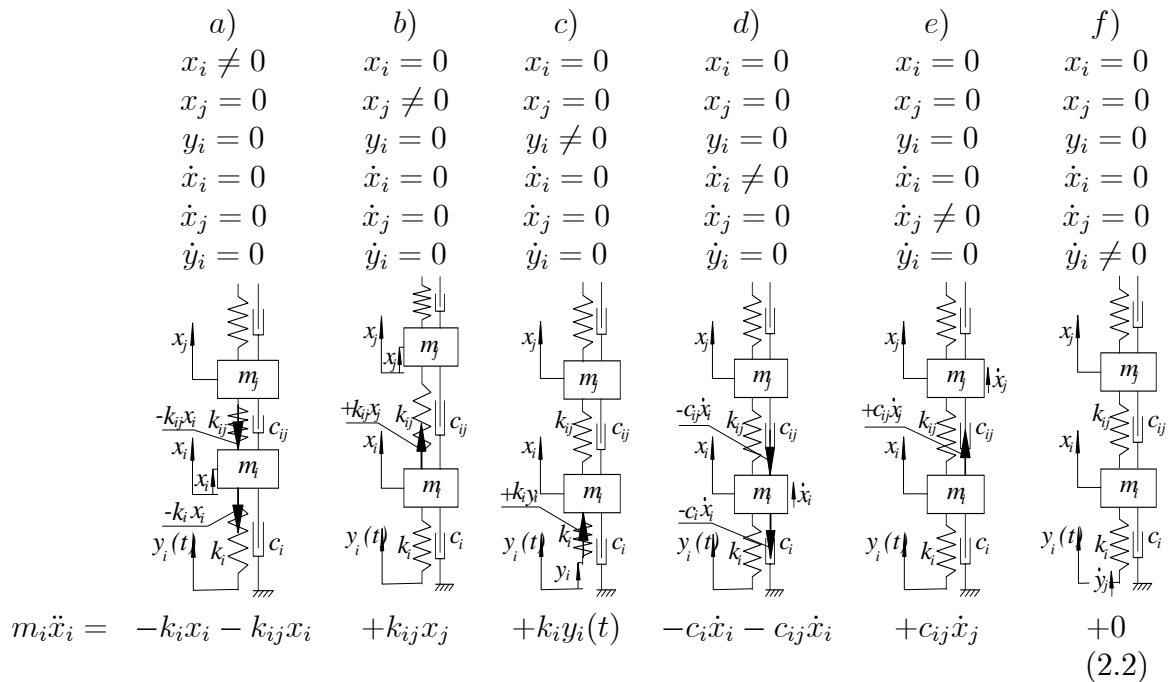

Due to this displacement there are two forces $k_i x_i$ and $k_{ij} x_i$ acting on the considered mass m_i . Both of them must be taken with sign '-' because the positive displacement x_i causes forces opposite to the positive direction of axis x_i . Similar consideration carried out for the displacements along the axis x_j (configuration b)) and axis y_i (configuration c)) results in the term $+k_{ij} x_j$. and $+k_i y_i(t)$ respectively. Up to now it has been assumed that the velocities of the system along all coordinates are equal to zero and because of this the dampers do not produce any force. The last three configurations (d, e, and f) allow to take these forces into account. Due to motion of the system along the coordinate x_i with velocity \dot{x}_i two additional forces are created by the dampers c_i and c_{ij} . they are $-c_i \dot{x}_i$ and $-c_{ij} \dot{x}_i$. Both of them are caused by positive velocity and have sense opposite to the positive sense of axis x_i . Therefore they have to be taken with the sign '-'. The forces caused by motion along the axis x_j (configuration e)) and axis y_i (configuration f)) results in the term $+c_{ij} \dot{x}_j$. and 0 respectively. Since the system is linear, one can add all this forces together to obtain

$$m_i \ddot{x}_i = -k_i x_i - k_{ij} x_i + k_{ij} x_j + k_i y_i(t) - c_i \dot{x}_i - c_{ij} \dot{x}_i + c_{ij} \dot{x}_j \tag{2.3}$$

After standardization we have the final form of equation of motion of the mass m_i .

$$m_i \ddot{x}_i + (c_i + c_{ij}) \dot{x}_i - c_{ij} \dot{x}_j + (k_i + k_{ij}) x_i - k_{ij} x_j = k_i y_i(t) \tag{2.4}$$

To accomplished the mathematical model, one has to carry out similar consideration for each mass involved in the system. As a result of these consideration we are getting set of differential equation containing as many equations as the number of degree of freedom.

Lagrange method of formulation of the mathematical model

The same set of equation of motion one can get by utilization of the Lagrange's equations

$$\frac{d}{dt} \left(\frac{\partial}{\partial \dot{q}_m} T \right) - \frac{\partial}{\partial q_m} T + \frac{\partial V}{\partial q_m} = Q_m \quad m = 1, 2, \dots, M \quad (2.5)$$

where

T - is the system kinetic energy function

V - stands for the potential energy function

Q_m - is the generalized force along the generalized coordinate q_m

The kinetic energy function of the system considered is equal to sum of the kinetic energy of the individual rigid bodies the system is made of. Hence

$$T = \sum_{i=1}^I \left(\frac{1}{2} m_i v_i^2 + \frac{1}{2} \begin{bmatrix} \omega_{ix} & \omega_{iy} & \omega_{iz} \end{bmatrix} \begin{bmatrix} I_{ix} & 0 & 0 \\ 0 & I_{iy} & 0 \\ 0 & 0 & I_{iz} \end{bmatrix} \begin{bmatrix} \omega_{ix} \\ \omega_{iy} \\ \omega_{iz} \end{bmatrix} \right) \quad (2.6)$$

where

m_i - mass of the rigid body

v_i - absolute velocity of the centre of gravity of the body

$\omega_{ix}, \omega_{iy}, \omega_{iz}$, - components of the absolute angular velocity of the body

I_{ix}, I_{iy}, I_{iz} - The principal moments of inertia of the body about axes through its centre of gravity

Potential energy function V for the gravity force acting on the link i shown in Fig. 2 is

$$V_i = m_i g r_{GiZ} \quad (2.7)$$

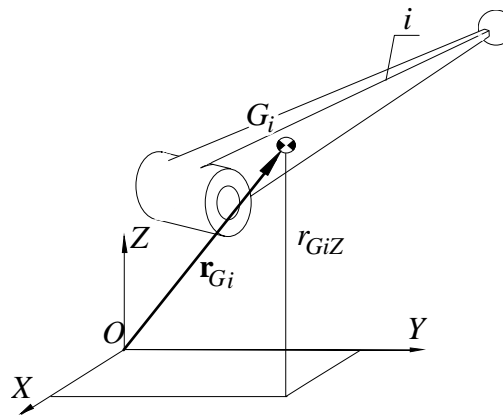

Figure 2

Potential energy for the spring s of stiffness k_s and uncompressed length l_s (see Fig. 3) is

$$V_s = \frac{1}{2} k_s (|\mathbf{r}_A - \mathbf{r}_B| - l_s)^2 \quad (2.8)$$

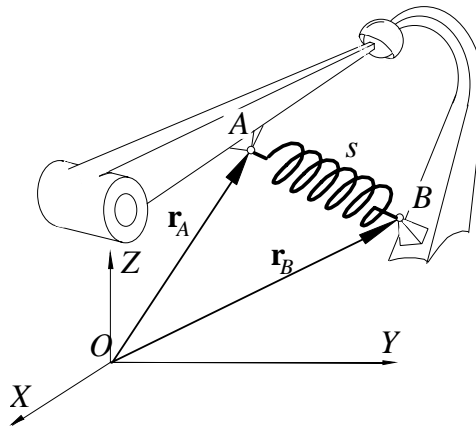

Figure 3

Potential energy function for all conservative forces acting on the system is

$$V = \sum_{i=1}^I V_i + \sum_{s=1}^S V_s \tag{2.9}$$

In a general case the damping forces should be classified as non-conservative ones and, as such, should be included in the generalized force Q_m . It must be remembered that the Lagrange's equations yield, in general case, a non-linear mathematical model. Therefore, before application of the developed in this chapter methods of analysis, the linearization process must be carried out. The following formula allows for any non-linear multi-variable function to be linearized in vicinity of the system equilibrium position $q_1^o, \dots, q_m^o, \dots, q_M^o$

$$f(q_1, \dots, q_m, \dots, q_M, \dot{q}_1, \dots, \dot{q}_m, \dots, \dot{q}_M) = f(q_1^o, \dots, q_m^o, \dots, q_M^o, 0, \dots, 0, \dots, 0) + \sum_{m=1}^M \frac{\partial f}{\partial q_m} (q_1^o, \dots, q_m^o, \dots, q_M^o, 0, \dots, 0, \dots, 0) \Delta q_m + \sum_{m=1}^M \frac{\partial f}{\partial \dot{q}_m} (q_1^o, \dots, q_m^o, \dots, q_M^o, 0, \dots, 0, \dots, 0) \Delta \dot{q}_m \tag{2.10}$$

In the case of the system shown in Fig. 1 the kinetic energy function is

$$T = \frac{1}{2}m_i\dot{x}_i^2 + \frac{1}{2}m_j\dot{x}_j^2 + \dots \tag{2.11}$$

Dots in the above equation represents this part of the kinetic energy function that does not depend on the generalized coordinate x_i .

If the system takes an arbitral position that is shown in Fig. 4, elongation of the springs k_i and k_{ij} are respectively

$$\Delta l_i = x_i - y_i \quad \Delta l_{ij} = x_j - x_i \tag{2.12}$$

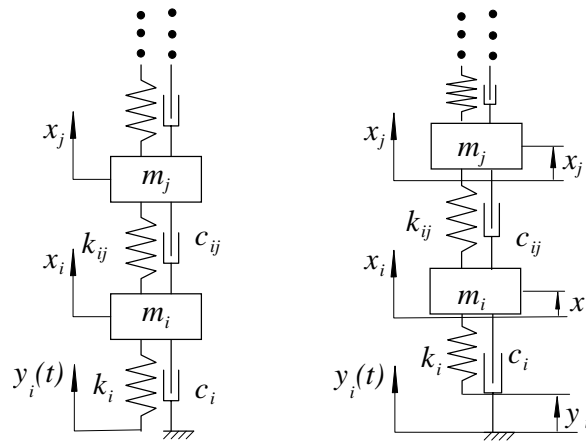

Figure 4

Therefore, the potential energy function is

$$V = \frac{1}{2}k_i(x_i - y_i)^2 + \frac{1}{2}k_{ij}(x_j - x_i)^2 + \dots \tag{2.13}$$

Again, dots stands for this part of the potential energy function that does not depend on the generalized coordinate x_i . It should be noted that the above potential energy function represents increment of the potential energy of the springs due to the displacement of the system from its equilibrium position. Therefore the above function does not include the potential energy due to the static deflection of the springs. It follows that the conservative forces due to the static deflections can not be produced from this potential energy function. They, together with the gravity forces, produce resultant equal to zero. Hence, if the potential energy due to the static deflections is not included in the function 2.13 the potential energy due to gravitation must not be included in the function 2.13 either. If the potential energy due to the static deflections is included in the function 2.13 the potential energy due to gravitation must be included in the function 2.13 too.

Generally, the force produced by the dampers is included in the generalized force Q_m . But, very often, for convenience, a damping function (dissipation function) D is introduced into the Lagrange's equation to produce the damping forces. The function D does not represent the dissipation energy but has such a property that its partial derivative produces the damping forces. The damping function is created by analogy to the creation of the potential energy function. The stiffness k is replaced by the damping coefficient c and the generalized displacements are replaced by the generalized velocities. Hence, in the considered case, since the lower end of the damper is motionless, the damping function is

$$D = \frac{1}{2}c_i(\dot{x}_i)^2 + \frac{1}{2}c_{ij}(\dot{x}_j - \dot{x}_i)^2 + \dots \tag{2.14}$$

The Lagrange's equation with the damping function takes form

$$\frac{d}{dt}\left(\frac{\partial}{\partial \dot{q}_m}T\right) - \frac{\partial}{\partial q_m}T + \frac{\partial V}{\partial q_m} + \frac{\partial D}{\partial \dot{q}_m} = Q_m \quad m = 1, 2, \dots, M \tag{2.15}$$

Introduction of the equations 2.11, 2.13 and 2.14 into equation 2.15 yields the equation of the motion of the mass m_i .

$$m_i \ddot{x}_i + (c_i + c_{ij}) \dot{x}_i - c_{ij} \dot{x}_j + (k_i + k_{ij}) x_i - k_{ij} x_j = k_i y_i(t) \quad (2.16)$$

The influence coefficient method

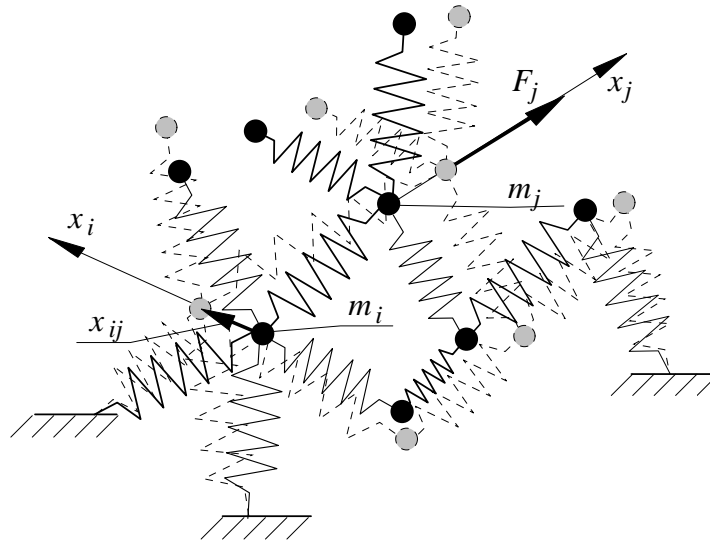

Figure 5

Let us consider the flexible structure shown in Fig. 5. Let us assume that the masses m_i and m_j can move along the coordinate x_i and x_j respectively. Let us apply to this system a static force F_j along the coordinate x_j . Let x_{ij} be the displacement of the system along the coordinate x_i caused by the force F_j .

DEFINITION: The ratio

$$\delta_{ij} = \frac{x_{ij}}{F_j} \quad (2.17)$$

is called the influence coefficient

It can be easily proved (see *Maxwell's reciprocity theorem*) that for any structure

$$\delta_{ij} = \delta_{ji} \quad (2.18)$$

If one apply forces along all I generalized coordinates x_i along which the system is allowed to move, the displacement along the $i - th$ coordinate, according to the superposition principle, is.

$$x_i = \sum_{j=1}^I \delta_{ij} F_j \quad i = 1, 2, \dots, I \quad (2.19)$$

These linear relationships can be written in the matrix form

$$\mathbf{x} = \delta \mathbf{F} \quad (2.20)$$

The inverse transformation permits to produce forces that have to act on the system along the individual coordinates if the system is at an arbitrarily chosen position \mathbf{x} .

$$\mathbf{F} = \boldsymbol{\delta}^{-1}\mathbf{x} \quad (2.21)$$

The inverse matrix $\boldsymbol{\delta}^{-1}$ is called *stiffness matrix* and will be denoted by \mathbf{k} .

$$\mathbf{k} = \boldsymbol{\delta}^{-1} \quad (2.22)$$

Hence according to equation 2.21 is

$$F_i = \sum_{j=1}^I k_{ij}x_j \quad (2.23)$$

If the system considered moves and its instantaneous position is determined by the vector \mathbf{x} ($x_1, \dots, x_j, \dots, x_I$) the force that acts on the particle m_i is

$$f_i = -F_i = -\sum_{j=1}^I k_{ij}x_j \quad (2.24)$$

Hence, application of the third Newton's law to the particle i yields the equation of its motion in the following form

$$m_i\ddot{x}_i + \sum_{j=1}^I k_{ij}x_j = 0 \quad (2.25)$$

2.1.3 Problems

Problem 16

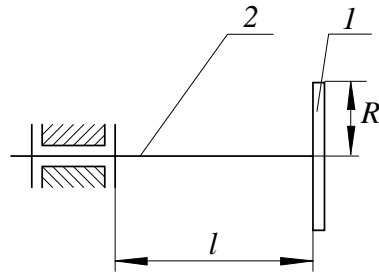

Figure 6

The disk 1 of radius R , and mass m is attached to the massless beam 2 of radius r , length l and the Young modulus E as shown in Fig. 6. Develop equations of motion of this system.

Solution.

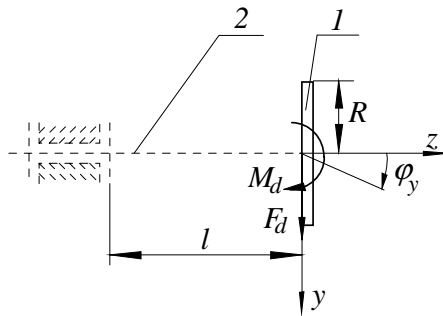

Figure 7

The motion of the disk shown in Fig. 7 is governed by Newton's equations

$$\begin{aligned} m\ddot{y} &= F_d \\ I\ddot{\varphi}_y &= M_d \end{aligned} \tag{2.26}$$

In the above mathematical model

$I = \frac{1}{4}mR^2$ - moment of inertia of the disk about axis x

F_d, M_d - forces acting on the disk due to its interaction with the beam

The interaction forces F_d and M_d can be expressed as a function of the displacements y and φ_y by means of the influence coefficient method.

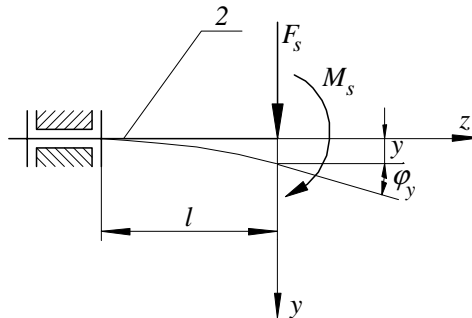

Figure 8

If the beam is loaded with force F_s (see Fig. 8), the corresponding displacements y and φ_y are

$$y = \frac{l^3}{3EJ}F_s \quad \varphi_y = \frac{l^2}{2EJ}F_s \tag{2.27}$$

If the beam is loaded with force M_s (see Fig. 8), the corresponding displacements y and φ_y are

$$y = \frac{l^2}{2EJ}M_s, \quad \varphi_y = \frac{l}{EJ}M_s \tag{2.28}$$

Hence the total displacement along coordinates y and φ_y are

$$\begin{aligned} y &= \frac{l^3}{3EJ}F_s + \frac{l^2}{2EJ}M_s \\ \varphi_y &= \frac{l^2}{2EJ}F_s + \frac{l}{EJ}M_s \end{aligned} \quad (2.29)$$

or in matrix form

$$\begin{bmatrix} y \\ \varphi_y \end{bmatrix} = \begin{bmatrix} \frac{l^3}{3EJ} & \frac{l^2}{2EJ} \\ \frac{l^2}{2EJ} & \frac{l}{EJ} \end{bmatrix} \begin{bmatrix} F_s \\ M_s \end{bmatrix} \quad (2.30)$$

where

$$J = \frac{\pi r^4}{4} \quad (2.31)$$

The inverse transformation yields the wanted forces as function of the displacements

$$\begin{bmatrix} F_s \\ M_s \end{bmatrix} = \begin{bmatrix} \frac{l^3}{3EJ} & \frac{l^2}{2EJ} \\ \frac{l^2}{2EJ} & \frac{l}{EJ} \end{bmatrix}^{-1} \begin{bmatrix} y \\ \varphi_y \end{bmatrix} = \begin{bmatrix} k_{11} & k_{12} \\ k_{21} & k_{22} \end{bmatrix} \begin{bmatrix} y \\ \varphi_y \end{bmatrix} \quad (2.32)$$

Since, according to the second Newton's law

$$\begin{bmatrix} F_d \\ M_d \end{bmatrix} = - \begin{bmatrix} F_s \\ M_s \end{bmatrix} \quad (2.33)$$

the equation of motion takes the following form

$$\begin{bmatrix} m & 0 \\ 0 & I \end{bmatrix} \begin{bmatrix} \ddot{y} \\ \ddot{\varphi}_y \end{bmatrix} = - \begin{bmatrix} k_{11} & k_{12} \\ k_{21} & k_{22} \end{bmatrix} \begin{bmatrix} y \\ \varphi_y \end{bmatrix} \quad (2.34)$$

Hence, the final mathematical model of the system considered is

$$\mathbf{m}\ddot{\mathbf{x}} + \mathbf{k}\mathbf{x} = \mathbf{0} \quad (2.35)$$

where

$$\mathbf{m} = \begin{bmatrix} m & 0 \\ 0 & I \end{bmatrix}; \quad \mathbf{k} = \begin{bmatrix} k_{11} & k_{12} \\ k_{21} & k_{22} \end{bmatrix}; \quad \mathbf{x} = \begin{bmatrix} y \\ \varphi_y \end{bmatrix} \quad (2.36)$$

Problem 17

Figure 9

A rigid beam of mass m and the moments of inertia I about axis through its centre of gravity G is supported by massless springs k_1 , and as shown in Fig. 9. Produce equations of motion of the system.

Solution.

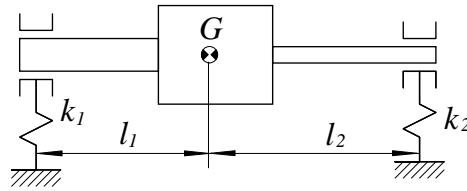
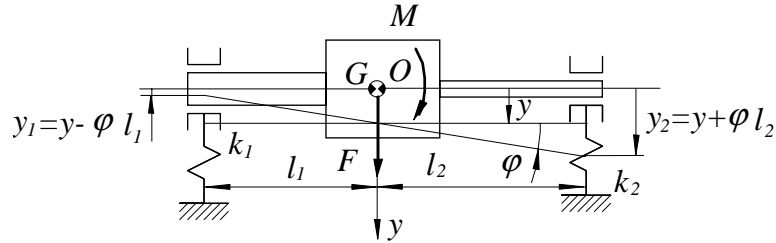

Figure 10

The system has two degree of freedom. Let us then introduce the two coordinates y and φ as shown in Fig. 10.

The force F and the moment M that act on the beam due to its motion along coordinates y and φ are

$$\begin{aligned}
 F &= -y_1 k_1 - y_2 k_2 = -(y - \varphi l_1) k_1 - (y + \varphi l_2) k_2 \\
 &= -[(k_1 + k_2)y + (k_2 l_2 - k_1 l_1)\varphi] \\
 M &= +y_1 k_1 l_1 - y_2 k_2 l_2 = +(y - \varphi l_1) k_1 l_1 - (y + \varphi l_2) k_2 l_2 \\
 &= -[(k_2 l_2 - k_1 l_1)y + (k_1 l_1^2 + y k_2 l_2^2)\varphi]
 \end{aligned} \tag{2.37}$$

Hence, the generalized Newton's equations yield

$$\begin{aligned}
 m\ddot{y} &= F = -[(k_1 + k_2)y + (k_2 l_2 - k_1 l_1)\varphi] \\
 I\ddot{\varphi} &= M = -[(k_2 l_2 - k_1 l_1)y + (k_1 l_1^2 + y k_2 l_2^2)\varphi]
 \end{aligned} \tag{2.38}$$

The matrix form of the system equations of motion is

$$\mathbf{m}\ddot{\mathbf{x}} + \mathbf{k}\mathbf{x} = \mathbf{0} \tag{2.39}$$

where

$$\mathbf{m} = \begin{bmatrix} m & 0 \\ 0 & I \end{bmatrix}; \quad \mathbf{k} = \begin{bmatrix} k_1 + k_2 & k_2 l_2 - k_1 l_1 \\ k_2 l_2 - k_1 l_1 & k_1 l_1^2 + k_2 l_2^2 \end{bmatrix}; \quad \mathbf{x} = \begin{bmatrix} y \\ \varphi \end{bmatrix} \tag{2.40}$$

Problem 18

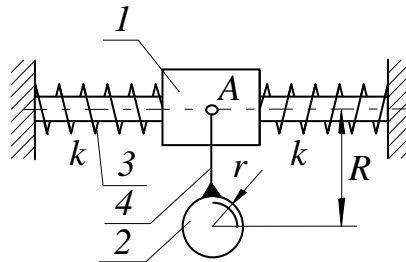

Figure 11

The link 1 of a mass m_1 , shown in Fig. 11), can move along the horizontal slide and is supported by two springs 3 each of stiffness k . The ball 2 of mass m_2 and a radius r and the massless rod 4 form a rigid body. This body is hinged to the link 1 at the point A. All motion is in the vertical plane. Use Lagrange's approach to derive equations of small vibrations of the system about its equilibrium position. $I = \frac{2}{5}m_2r^2$ — moment of inertia of the ball about axis through its centre of gravity.

Solution

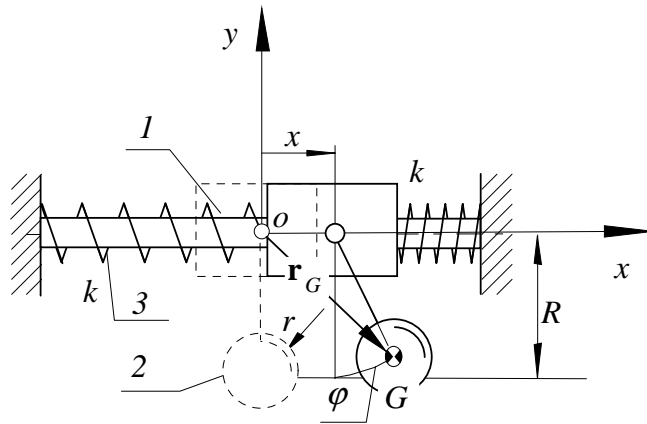

Figure 12

The system has two degree of freedom and the two generalized coordinates x and φ are shown in Fig. 12. The kinetic energy of the system T is equal to the sum of the kinetic energy of the link 1 T_1 and the link 2 T_2 .

$$T = T_1 + T_2 = \frac{1}{2}m_1\dot{x}^2 + \frac{1}{2}m_2v_G^2 + \frac{1}{2}I\dot{\varphi}^2 \quad (2.41)$$

The absolute velocity of the centre of gravity of the ball \mathbf{v}_G can be obtained by differentiation of its absolute position vector. According to Fig .12, this position vector is

$$\mathbf{r}_G = \mathbf{i}(x + R \sin \varphi) + \mathbf{j}(- R \cos \varphi) \quad (2.42)$$

Hence

$$\mathbf{v}_G = \dot{\mathbf{r}}_G = \mathbf{i}(\dot{x} + R\dot{\varphi} \cos \varphi) + \mathbf{j}(R\dot{\varphi} \sin \varphi) \quad (2.43)$$

The required squared magnitude of this velocity is

$$v_G^2 = (\dot{x} + R\dot{\varphi} \cos \varphi)^2 + (R\dot{\varphi} \sin \varphi)^2 = \dot{x}^2 + 2\dot{x}R\dot{\varphi} \cos \varphi + R^2\dot{\varphi}^2 \quad (2.44)$$

Introduction of Eq. 2.44 into Eq. 2.41 yields the kinetic energy function of the system as a function of the generalized coordinates x and φ .

$$\begin{aligned} T &= \frac{1}{2}m_1\dot{x}^2 + \frac{1}{2}m_2(\dot{x}^2 + 2\dot{x}R\dot{\varphi} \cos \varphi + R^2\dot{\varphi}^2) + \frac{1}{2}I\dot{\varphi}^2 \\ &= \frac{1}{2}(m_1 + m_2)\dot{x}^2 + m_2R\dot{x}\dot{\varphi} \cos \varphi + \frac{1}{2}(m_2R^2 + I)\dot{\varphi}^2 \end{aligned} \quad (2.45)$$

The potential energy function is due the energy stored in the springs and the energy due to gravitation.

$$V = 2\frac{1}{2}kx^2 - m_2gR \cos \varphi \quad (2.46)$$

In the case considered, the Lagrange's equations can be adopted in the following form

$$\begin{aligned} \frac{d}{dt} \left(\frac{\partial T}{\partial \dot{x}} \right) - \frac{\partial T}{\partial x} + \frac{\partial V}{\partial x} &= 0 \\ \frac{d}{dt} \left(\frac{\partial T}{\partial \dot{\varphi}} \right) - \frac{\partial T}{\partial \varphi} + \frac{\partial V}{\partial \varphi} &= 0 \end{aligned} \quad (2.47)$$

The individual terms that appear in the above equation are

$$\begin{aligned} \frac{d}{dt} \left(\frac{\partial T}{\partial \dot{x}} \right) &= \frac{d}{dt} ((m_1 + m_2)\dot{x} + m_2 R \dot{\varphi} \cos \varphi) = \\ &= (m_1 + m_2)\ddot{x} + m_2 R \ddot{\varphi} \cos \varphi - m_2 R \dot{\varphi}^2 \sin \varphi \end{aligned} \quad (2.48)$$

$$\frac{\partial T}{\partial x} = 0 \quad (2.49)$$

$$\frac{\partial V}{\partial x} = 2kx \quad (2.50)$$

$$\begin{aligned} \frac{d}{dt} \left(\frac{\partial T}{\partial \dot{\varphi}} \right) &= \frac{d}{dt} (m_2 R \dot{x} \cos \varphi + (m_2 R^2 + I)\dot{\varphi}) = \\ &= (m_2 R^2 + I)\ddot{\varphi} + m_2 R \ddot{x} \cos \varphi - m_2 R \dot{x} \dot{\varphi} \sin \varphi \end{aligned} \quad (2.51)$$

$$\frac{\partial T}{\partial \varphi} = -m_2 R \dot{x} \dot{\varphi} \sin \varphi \quad (2.52)$$

$$\frac{\partial V}{\partial \varphi} = m_2 g R \sin \varphi \quad (2.53)$$

Hence, according to Eq. 2.47, we have the following equations of motion

$$\begin{aligned} (m_1 + m_2)\ddot{x} + m_2 R \ddot{\varphi} \cos \varphi - m_2 R \dot{\varphi}^2 \sin \varphi + 2kx &= 0 \\ (m_2 R^2 + I)\ddot{\varphi} + m_2 R \ddot{x} \cos \varphi + m_2 g R \sin \varphi &= 0 \end{aligned} \quad (2.54)$$

For small magnitudes of x and φ , $\sin \varphi \cong \varphi$, $\cos \varphi \cong 1$, $\dot{\varphi}^2 \cong 0$. Taking this into account the linearized equations of motion are

$$\begin{aligned} (m_1 + m_2)\ddot{x} + m_2 R \ddot{\varphi} + 2kx &= 0 \\ (m_2 R^2 + I)\ddot{\varphi} + m_2 R \ddot{x} + m_2 g R \varphi &= 0 \end{aligned} \quad (2.55)$$

Their matrix form is

$$\mathbf{m}\ddot{\mathbf{x}} + \mathbf{k}\mathbf{x} = \mathbf{0} \quad (2.56)$$

where

$$\mathbf{m} = \begin{bmatrix} m_1 + m_2 & m_2 R \\ m_2 R & m_2 R^2 + I \end{bmatrix}, \quad \mathbf{k} = \begin{bmatrix} 2k & 0 \\ 0 & m_2 g R \end{bmatrix}, \quad \mathbf{x} = \begin{bmatrix} x \\ \varphi \end{bmatrix} \quad (2.57)$$

Problem 19

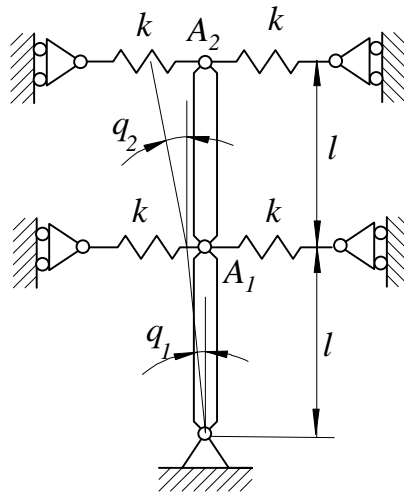

Figure 13

Two identical and uniform rods shown in Fig. 13, each of mass m and length l , are joined together to form an inverse double pendulum. The pendulum is supported by four springs, all of stiffness k , in such way that its vertical position ($q_1 = 0$ and $q_2 = 0$) is its stable equilibrium position. Produce equation of small vibrations of the pendulum about this equilibrium position.

Problem 20

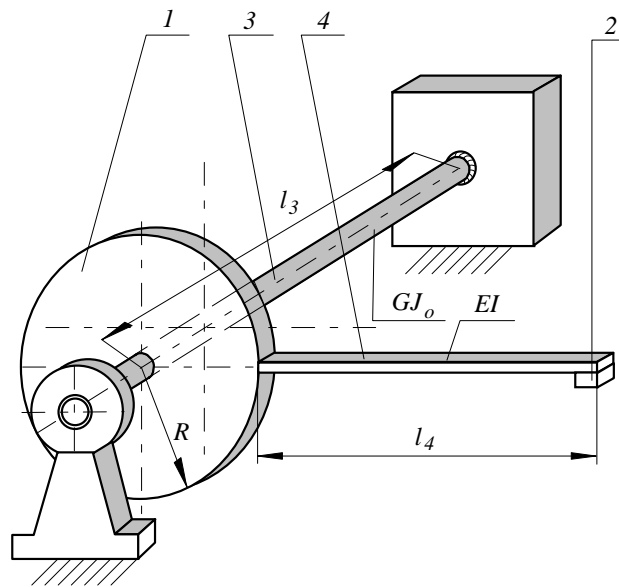

Figure 14

The disk 1 of mass m_1 and radius R shown in Fig. 14, is fasten to the massless and flexible shaft 3. The left hand end of the massless and flexible beam 4 is rigidly attached to the disk 1. At its right hand side the particle 2 of m_2 is placed. Derive equations for analysis of small vibrations of the system.

Problem 21

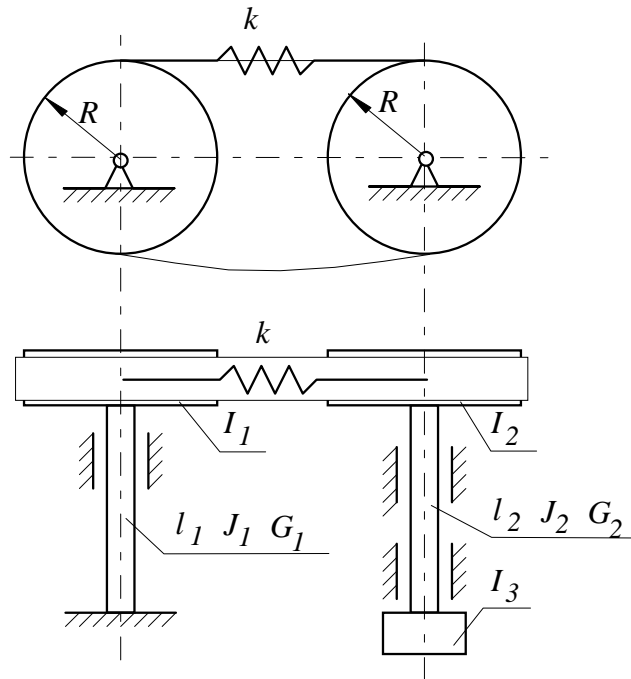

Figure 15

A belt gear was modelled as shown in Fig. 15. The shafts are assumed to be massless and their length the second moment of inertia and the shear modulus is denoted by l , J , and G respectively. The disks have moments of inertia I_1 , I_2 , and I_3 . The belt is modelled as the spring of a stiffness k . Derive the differential equations for the torsional vibrations of the system.

Problem 22

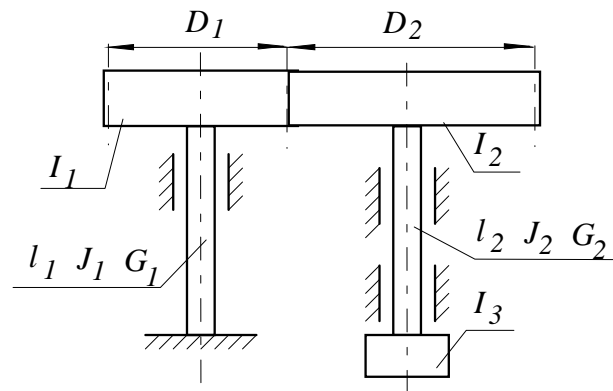

Figure 16

In Fig. 16 the physical model of a gear box is presented. Derive equations for the torsional vibrations of the gear box. The shafts the gears are mounted on are massless.

Problem 23

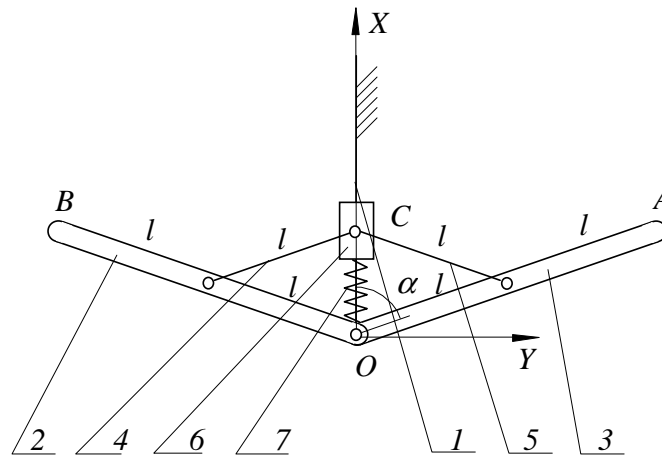

Figure 17

Fig. 17 shows a mechanical system. Link 1 of the system is motionless with respect to the inertial system of coordinates XY . The links 2 and 3 are hinged to the link 1 at the point O . The links 4 and 5 join the links 2 and 3 with the collar 6. The spring 7 has a stiffness k and its uncompressed length is equal to $2l$. The system has one degree of freedom and its position may be determined by one generalized coordinate α . The links 4 5 and 6 are assumed to be massless. The links 2 and 3 can be treated as thin and uniform bars each of length $2l$ and mass m .

Derive equations of the small vibration of the system about its equilibrium position.

Problem 24

Figure 18

Three beads, each of mass m are attached to the massless string shown in Fig. 18. The string has length l and is loaded with the tensile force T . Derive equation of motion of the beads

Problem 25

Figure 19

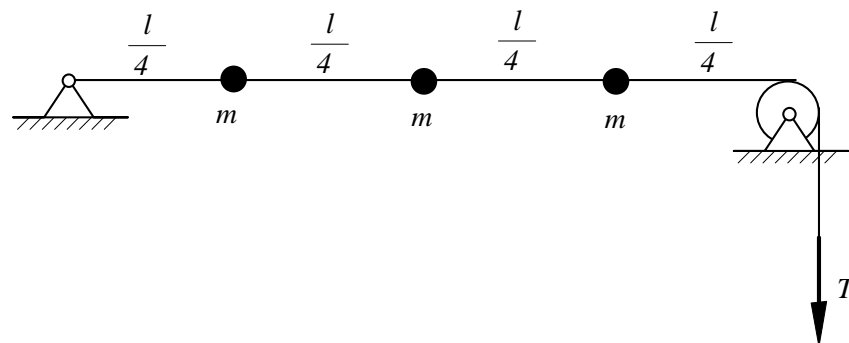
On the massless string of length l the ball of mass m and radius R is suspended (see Fig. 19). Derive equation of motion of the system.

Problem 26

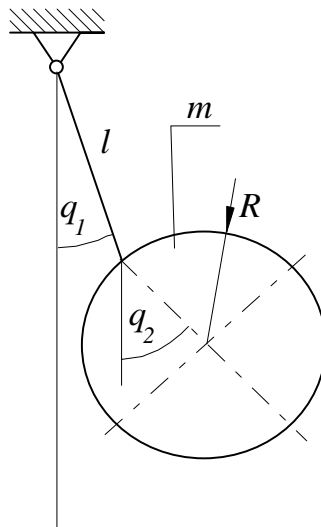
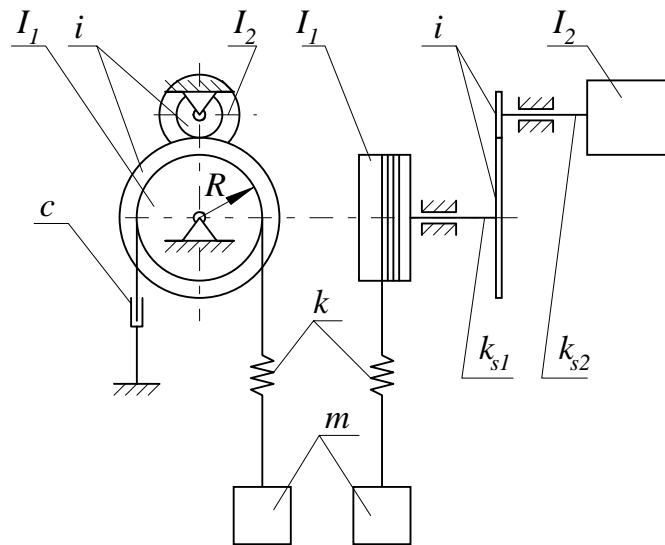

Figure 20

Fig. 20 presents the physical model of a winch. The shafts of the torsional stiffness k_{s1} and k_{s2} as well as the gear of ratio i are massless. To the right hand end of the shaft k_{s2} the rotor of the moment of inertia I_2 is attached. The left hand end of the shaft k_{s1} is connected to the drum of the moment of inertia I_1 . The rope is modelled as a massless spring of the stiffness k . At its end the block of mass m is fastened. The damper of the damping coefficient c represents the damping properties of the system.

Produce the differential equation of motion of the system.

Solution

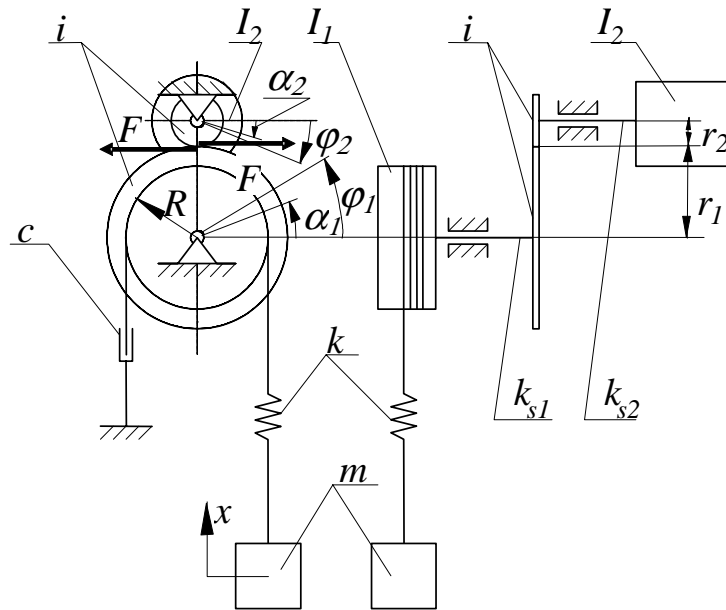

Figure 21

In Fig. 21 x , φ_1 and φ_2 are the independent coordinates. Since the gear ratio as well as the shafts of stiffness k_{s1} and k_{s2} are massless the coordinates that specify the position of the gear α_1 and α_2 are not independent. They are a function of the independent coordinates.

Let

$$i = \frac{r_1}{r_2} = \frac{\alpha_2}{\alpha_1} \tag{2.58}$$

Application of the Newton's law to the individual bodies yields equations of motion in the following form.

$$m\ddot{x} = -kx + Rk\varphi_1 \tag{2.59}$$

$$I_1\ddot{\varphi}_1 = +kRx - kR^2\varphi_1 - cR^2\dot{\varphi}_1 - k_{s1}\varphi_1 + k_{s1}\alpha_1 \tag{2.60}$$

$$0\ddot{\alpha}_1 = -k_{s1}\alpha_1 + k_{s1}\varphi_1 + Fr_1 \tag{2.61}$$

$$0\ddot{\alpha}_2 = -k_{s2}\alpha_2 + k_{s2}\varphi_2 - Fr_2 \tag{2.62}$$

$$I_2\ddot{\varphi}_2 = -k_{s2}\varphi_2 + k_{s2}\alpha_2 \tag{2.63}$$

Introducing 2.58 into the equations 2.61 and 2.62 one can obtain

$$0 = -k_{s1}\alpha_1 + k_{s1}\varphi_1 + iFr_2 \tag{2.64}$$

$$0 = -k_{s2}i\alpha_1 + k_{s2}\varphi_2 - Fr_2 \tag{2.65}$$

Solving the above equations for α_1 we have

$$\alpha_1 = \frac{k_{s1}\varphi_1 + ik_{s2}\varphi_2}{k_{s1} + k_{s2}i^2} \tag{2.66}$$

Hence, according to 2.58

$$\alpha_2 = i\alpha_1 = \frac{ik_{s1}\varphi_1 + i^2k_{s2}\varphi_2}{k_{s1} + k_{s2}i^2} \quad (2.67)$$

Introducing 2.66 and 2.67 into 2.60 and 2.63 one can get the equations of motion in the following form

$$\begin{aligned} m\ddot{x} &= -kx + Rk\varphi_1 \\ I_1\ddot{\varphi}_1 &= +kRx - kR^2\varphi_1 - cR^2\dot{\varphi}_1 - k_{s1}\varphi_1 + k_{s1}\frac{k_{s1}\varphi_1 + ik_{s2}\varphi_2}{k_{s1} + k_{s2}i^2} \\ \ddot{\varphi}_2 &= -k_{s2}\varphi_2 + k_{s2}\frac{ik_{s1}\varphi_1 + i^2k_{s2}\varphi_2}{k_{s1} + k_{s2}i^2} \end{aligned} \quad (2.68)$$

After standardization we have

$$\mathbf{m}\ddot{\mathbf{z}} + \mathbf{c}\dot{\mathbf{z}} + \mathbf{kz} = \mathbf{0}$$

where

$$\begin{aligned} \mathbf{m} &= \begin{bmatrix} m & 0 & 0 \\ 0 & I_1 & 0 \\ 0 & 0 & I_2i^2 \end{bmatrix}; & \mathbf{c} &= \begin{bmatrix} 0 & 0 & 0 \\ 0 & cR^2 & 0 \\ 0 & 0 & 0 \end{bmatrix}; \\ \mathbf{k} &= \begin{bmatrix} k & -kR & 0 \\ -kR & kR^2 + \frac{k_{s1}k_{s2}i^2}{k_{s1}+k_{s2}i^2} & -\frac{k_{s1}k_{s2}i^2}{k_{s1}+k_{s2}i^2} \\ 0 & -\frac{k_{s1}k_{s2}i^2}{k_{s1}+k_{s2}i^2} & \frac{k_{s1}k_{s2}i^2}{k_{s1}+k_{s2}i^2} \end{bmatrix}; & \mathbf{z} &= \begin{bmatrix} x \\ \varphi_1 \\ \frac{\varphi_2}{i} \end{bmatrix} \end{aligned} \quad (2.69)$$

Problem 27

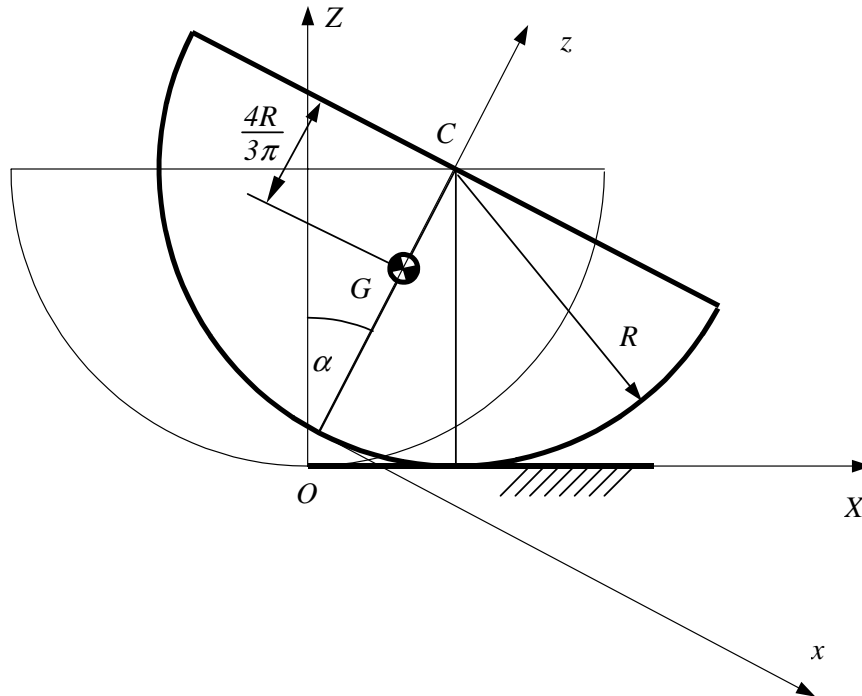

Figure 22

The semi-cylinder of mass m and radius R shown in Fig. 50 is free to roll over the horizontal plane XY without slipping. The instantaneous angular position of this semi-cylinder is determined by the angular displacement α . Produce

1. the equation of small oscillations of the semi-cylinder (take advantage of the Lagrange's equations)

Answer:

$$\left(I_G + mR^2 \left(1 + \frac{16}{9\pi^2} - \frac{8}{3\pi}\right)\right) \ddot{\alpha} + mgR\left(1 - \frac{4}{3\pi}\right)\alpha = 0$$

where $I_G = \frac{1}{2}mR^2 - m\left(\frac{4R}{3\pi}\right)^2$

2. the expression for period of these oscillations.

Answer:

$$T = \frac{2\pi}{\sqrt{\frac{mgR\left(1 - \frac{4}{3\pi}\right)}{\left(I_G + mR^2\left(1 + \frac{16}{9\pi^2} - \frac{8}{3\pi}\right)\right)}}$$

Problem 28

Figure 23

The two disks of moments of inertia I_1 and I_2 are joined together by means of the massless shafts as is shown in Fig. 51. The dynamic properties of the shafts are determined by their lengths l , the second moments of area J and the shear modulus G . Produce the differential equations of motion.

2.2 ANALYSIS OF MULTI-DEGREE-OF-FREEDOM SYSTEM

The analysis carried out in the previous section leads to the conclusion that the mathematical model of the linear multi-degree-of-freedom system is as follows

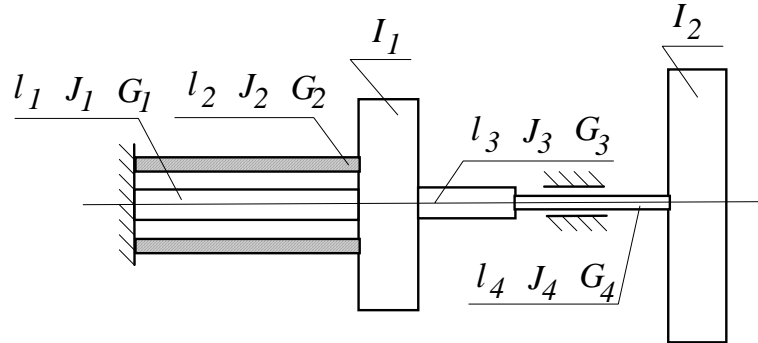
$$\mathbf{m}\ddot{\mathbf{x}} + \mathbf{c}\dot{\mathbf{x}} + \mathbf{k}\mathbf{x} = \mathbf{F}(t) \quad (2.70)$$

where

- \mathbf{m} - matrix of inertia
- \mathbf{c} - matrix of damping
- \mathbf{k} - matrix of stiffness
- $\mathbf{F}(t)$ - vector of the external excitation
- \mathbf{x} - vector of the generalized coordinates

2.2.1 General case

In the general case of the multi-degree-of-freedom system the matrices \mathbf{c} and \mathbf{k} do not necessarily have to be symmetrical. Such a situation takes place, for example, if the mechanical structure interacts with fluid or air (oil bearings, flutter of plane wings etc.). Since the equation 2.70 is linear, its general solution is always equal to the sum of the general solution of the homogeneous equation \mathbf{x}_g and the particular solution of the non-homogeneous equation \mathbf{x}_p .

$$\mathbf{x} = \mathbf{x}_g + \mathbf{x}_p \quad (2.71)$$

The homogeneous equation

$$\mathbf{m}\ddot{\mathbf{x}} + \mathbf{c}\dot{\mathbf{x}} + \mathbf{k}\mathbf{x} = \mathbf{0} \quad (2.72)$$

corresponds to the case when the excitation $\mathbf{F}(t)$ is not present. Therefore, its general solution represents the *free* (natural) *vibrations* of the system. The particular solution of the non-homogeneous equation 2.70 represents the vibrations caused by the excitation force $\mathbf{F}(t)$. It is often referred to as the *forced vibrations*.

Free vibrations - natural frequencies- stability of the equilibrium position

To analyze the free vibrations let us transfer the homogeneous equation 2.72 to so called *state-space coordinates*. Let

$$\mathbf{y} = \dot{\mathbf{x}} \quad (2.73)$$

be the vector of the *generalized velocities*. Introduction of Eq. 2.73 into Eq. 2.72 yields the following set of the differential equations of first order.

$$\begin{aligned} \dot{\mathbf{x}} &= \mathbf{y} \\ \dot{\mathbf{y}} &= -\mathbf{m}^{-1}\mathbf{k}\mathbf{x} - \mathbf{m}^{-1}\mathbf{c}\mathbf{y} \end{aligned} \quad (2.74)$$

The above equations can be rewritten as follows

$$\dot{\mathbf{z}} = \mathbf{A}\mathbf{z} \quad (2.75)$$

where

$$\mathbf{z} = \begin{bmatrix} \mathbf{x} \\ \mathbf{y} \end{bmatrix}, \quad \mathbf{A} = \begin{bmatrix} \mathbf{0} & \mathbf{1} \\ -\mathbf{m}^{-1}\mathbf{k} & -\mathbf{m}^{-1}\mathbf{c} \end{bmatrix} \quad (2.76)$$

Solution of the above equation can be predicted in the form 2.77.

$$\mathbf{z} = \mathbf{z}_0 e^{rt} \quad (2.77)$$

Introduction of Eq. 2.77 into Eq. 2.75 results in a set of the homogeneous algebraic equations which are linear with respect to the vector \mathbf{z}_0 .

$$[\mathbf{A} - r\mathbf{I}]\mathbf{z}_0 = \mathbf{0} \quad (2.78)$$

The equations 2.78 have non-zero solution if and only if the characteristic determinant is equal to 0.

$$|[\mathbf{A} - r\mathbf{I}]| = 0 \quad (2.79)$$

The process of searching for a solution of the equation 2.79 is called *eigenvalue problem* and the process of searching for the corresponding vector \mathbf{z}_0 is called *eigenvector problem*. Both of them can be easily solved by means of the commercially available computer programs.

The roots r_n are usually complex and conjugated.

$$r_n = h_n \pm i\omega_n \quad n = 1, \dots, N \quad (2.80)$$

Their number N is equal to the number of degree of freedom of the system considered. The particular solutions corresponding to the complex roots 2.80 are

$$\begin{aligned} \mathbf{z}_{n1} &= e^{h_n t} (\text{Re}(\mathbf{z}_{0n}) \cos \omega_n t - \text{Im}(\mathbf{z}_{0n}) \sin \omega_n t) \\ \mathbf{z}_{n2} &= e^{h_n t} (\text{Re}(\mathbf{z}_{0n}) \sin \omega_n t + \text{Im}(\mathbf{z}_{0n}) \cos \omega_n t) \quad n = 1, \dots, N \end{aligned} \quad (2.81)$$

In the above expressions $\text{Re}(\mathbf{z}_{0_n})$ and $\text{Im}(\mathbf{z}_{0_n})$ stand for the real and imaginary part of the complex and conjugated eigenvector \mathbf{z}_{0_n} associated with the n^{th} root of the set 2.80 respectively. The particular solutions 2.81 allow to formulate the general solution that approximates the system free vibrations..

$$\mathbf{z} = [\mathbf{z}_{11}, \mathbf{z}_{12}, \mathbf{z}_{21}, \mathbf{z}_{22}, \mathbf{z}_{31}, \mathbf{z}_{32}, \dots, \mathbf{z}_{n1}, \mathbf{z}_{n2}, \dots, \mathbf{z}_{N1}, \mathbf{z}_{N2}] \mathbf{C} \quad (2.82)$$

As one can see from the formulae 2.81, **the imaginary parts of roots r_n represent the natural frequencies of the system** and their **real parts represent rate of decay of the free vibrations**. The system with N degree of freedom possesses N natural frequencies. The equation 2.82 indicates that the free motion of a multi-degree-of-freedom system is a linear combination of the solutions 2.81.

A graphical interpretation of the solutions 2.81 is given in Fig. 24 for the positive and negative magnitude of h_n . The problem of searching for the vector of the

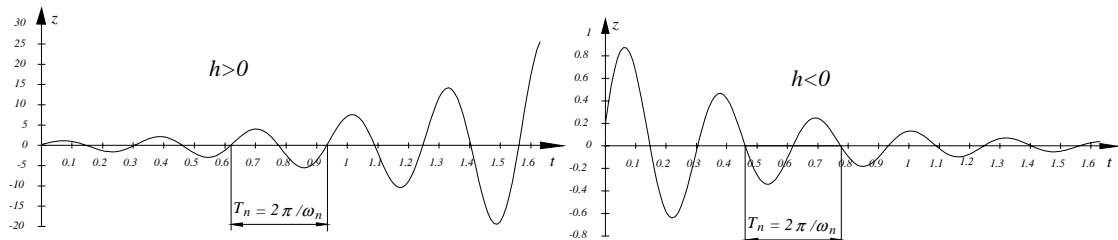

Figure 24

constant magnitudes \mathbf{C} is called *initial problem*. In the general case, this problem is difficult and goes beyond the scope of this lectures.

The roots 2.80 allow the stability of the system equilibrium position to be determined.

If all roots r_n of the equation 2.80 have negative real parts then the equilibrium position of the system considered is stable.

If at least one root of the equation 2.80 has positive real part then the equilibrium position of the system considered is unstable.

Forced vibrations - transfer functions

The response to the external excitation $\mathbf{F}(t)$ of a multi-degree-of-freedom system is determined by the particular solution of the mathematical model 2.70.

$$\mathbf{m}\ddot{\mathbf{x}} + \mathbf{c}\dot{\mathbf{x}} + \mathbf{k}\mathbf{x} = \mathbf{F}(t) \quad (2.83)$$

Let us assume that the excitation force $\mathbf{F}(t)$ is a sum of K addends. For the further analysis let us assume that each of them has the following form

$$F^k = F_o^k \cos(\omega t + \varphi_o^k) \quad (2.84)$$

To facilitate the process of looking for the particular solution of equation 2.83, let us introduce the complex excitation force by adding to the expression 2.84 the imaginary part.

$$f^k = F_o^k \cos(\omega t + \varphi_o^k) + iF_o^k \sin(\omega t + \varphi_o^k) \quad (2.85)$$

The relationship between the complex excitation f^k and the real excitation is shown in Fig. 25. According to Euler's formula the complex excitation may be rewritten as

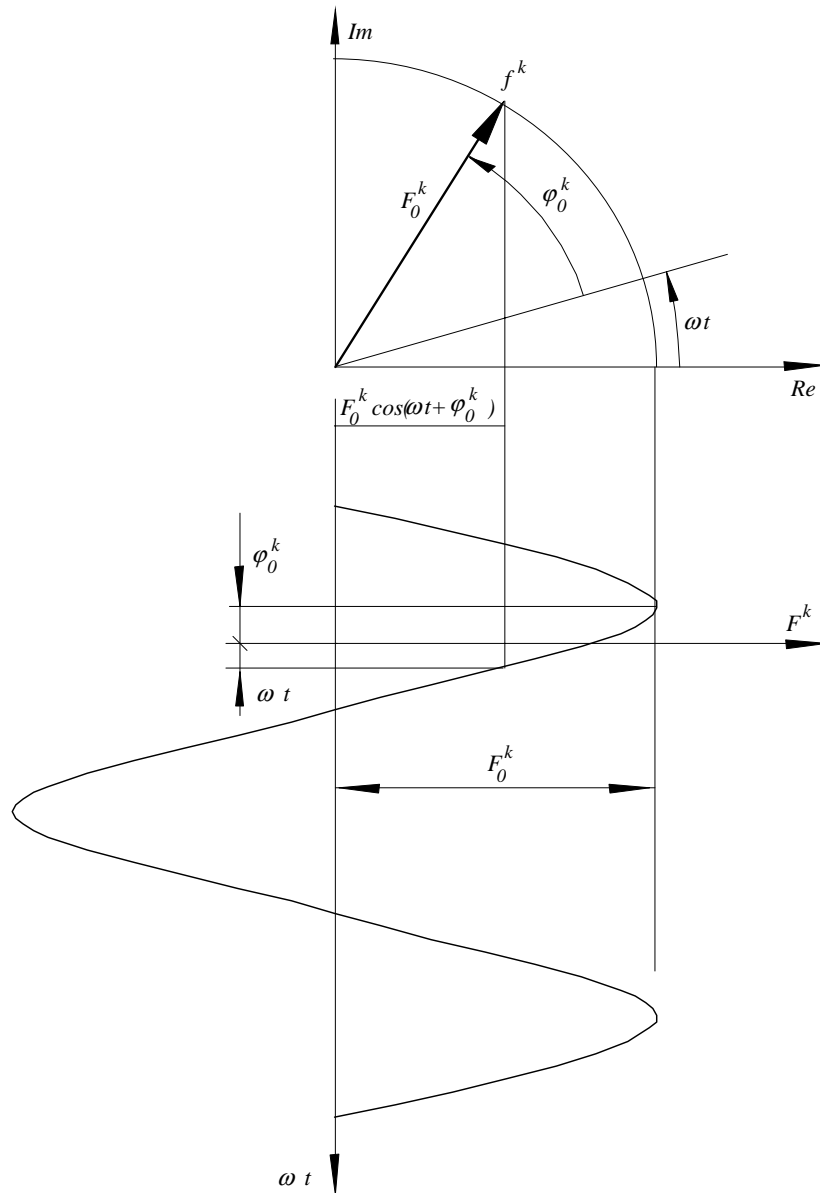

Figure 25

follows

$$f^k = F_0^k e^{i(\omega t + \varphi_0^k)} = F_0^k e^{i\varphi_0^k} e^{i\omega t} = f_o^k e^{i\omega t} \quad (2.86)$$

Here, f_o^k is a complex number that depends on the amplitude and phase of the external excitation. Introduction of Eq. 2.86 into Eq. 2.83 yields

$$\mathbf{m}\ddot{\mathbf{x}} + \mathbf{c}\dot{\mathbf{x}} + \mathbf{k}\mathbf{x} = \mathbf{f}_o e^{i\omega t} \quad (2.87)$$

Now, the particular solution of Eq. 2.87 can be predicted in the complex form 2.88

$$\mathbf{x}^c = \mathbf{a} e^{i\omega t} \quad (2.88)$$

Introduction of Eq. 2.88 into Eq. 2.87 produces set of the algebraic equations which are linear with respect to the unknown vector \mathbf{a} .

$$(-\omega^2 \mathbf{m} + i\omega \mathbf{c} + \mathbf{k}) \mathbf{a} = \mathbf{f}_o \quad (2.89)$$

Its solution is

$$\mathbf{a} = (-\omega^2 \mathbf{m} + i\omega \mathbf{c} + \mathbf{k})^{-1} \mathbf{f}_o \quad (2.90)$$

Therefore, according to Eq. 2.88, the response of the system \mathbf{x}^c due to the complex force \mathbf{f} is

$$\mathbf{x}^c = (\text{Re}(\mathbf{a}) + i \text{Im}(\mathbf{a}))(\cos \omega t + i \sin \omega t) \quad (2.91)$$

Response of the system \mathbf{x} due to the real excitation \mathbf{F} is represented by the real part of the solution 2.91.

$$\mathbf{x} = \text{Re}(\mathbf{a}) \cos \omega t - \text{Im}(\mathbf{a}) \sin \omega t \quad (2.92)$$

Motion of the system considered along the coordinate x^k , according to 2.92 is

$$x^k = x_o^k \cos(\omega t + \beta^k) \quad (2.93)$$

where

$$x_o^k = \sqrt{\text{Re}(a^k)^2 + \text{Im}(a^k)^2} \quad \beta^k = \text{arc tan} \frac{\text{Im}(a^k)}{\text{Re}(a^k)} \quad (2.94)$$

It is easy to see from 2.91 that the amplitude of the forced vibration x_o^k is equal to the absolute value of the complex amplitude a^k , and its phase β^k is equal to the phase between the complex amplitudes a^k and the vector $e^{i\omega t}$. This findings are presented in Fig. 26.

The complex matrix

$$(-\omega^2 \mathbf{m} + i\omega \mathbf{c} + \mathbf{k})^{-1} \quad (2.95)$$

will be denoted by $\mathbf{R}(i\omega)$ and it is called *matrix of transfer functions*. It transfers, according to 2.90, the vector of the complex excitation $\mathbf{f}_o e^{i\omega t}$ into the vector of the complex displacement $\mathbf{x}^c = \mathbf{a} e^{i\omega t}$.

$$\mathbf{x}^c = \mathbf{a} e^{i\omega t} = \mathbf{R}(i\omega) \mathbf{f}_o e^{i\omega t} \quad (2.96)$$

It is easy to see that the element $R_{pq}(i\omega)$ of the matrix of transfer functions represents the complex displacement (amplitude and phase) of the system along the coordinates x_p caused by the unit excitation $1e^{i\omega t}$ along the coordinate x_q . Example of three elements of a matrix of the transform functions are presented in Fig. 27. The first two diagrams present the real and the imaginary parts of the complex transform functions whereas the last two present its absolute value (amplitude) and phase.

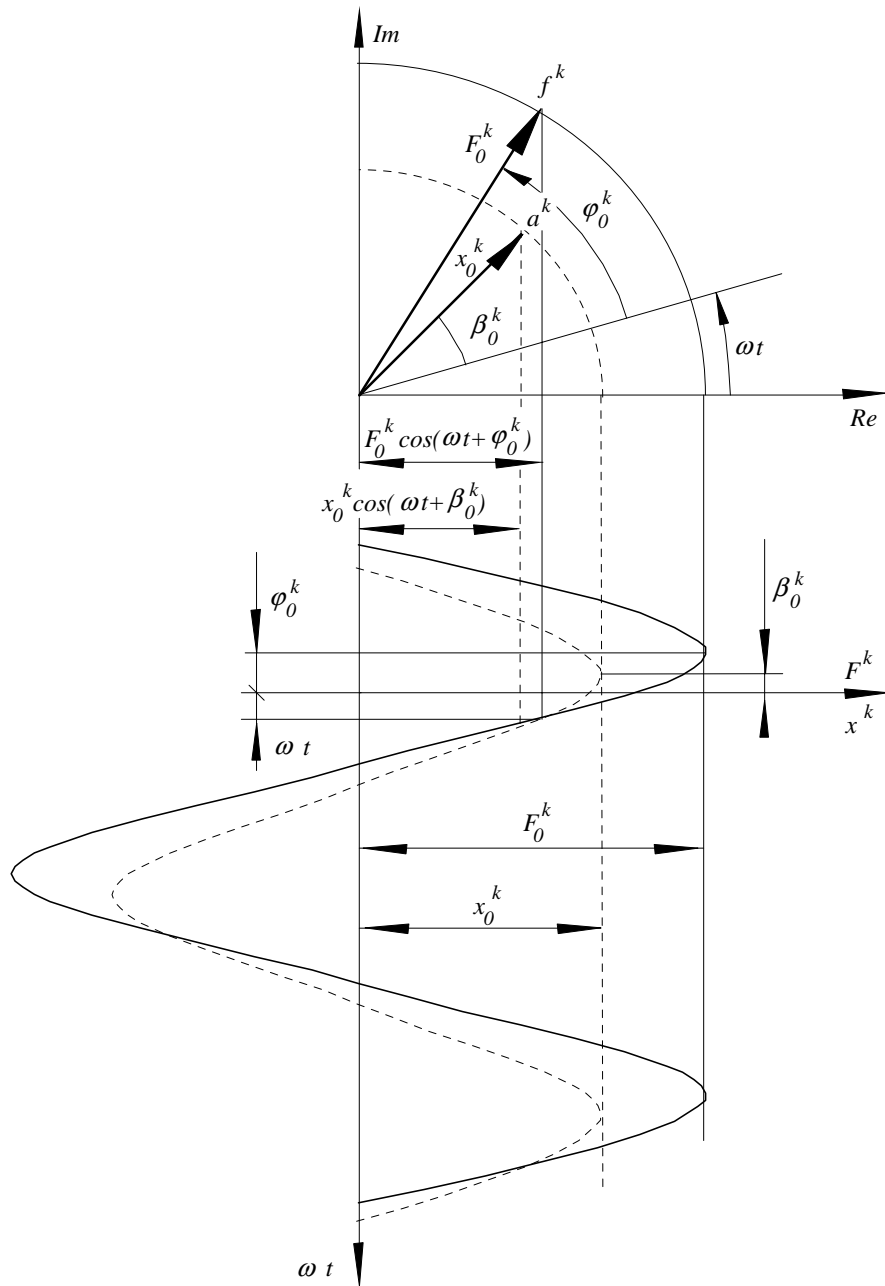

Figure 26

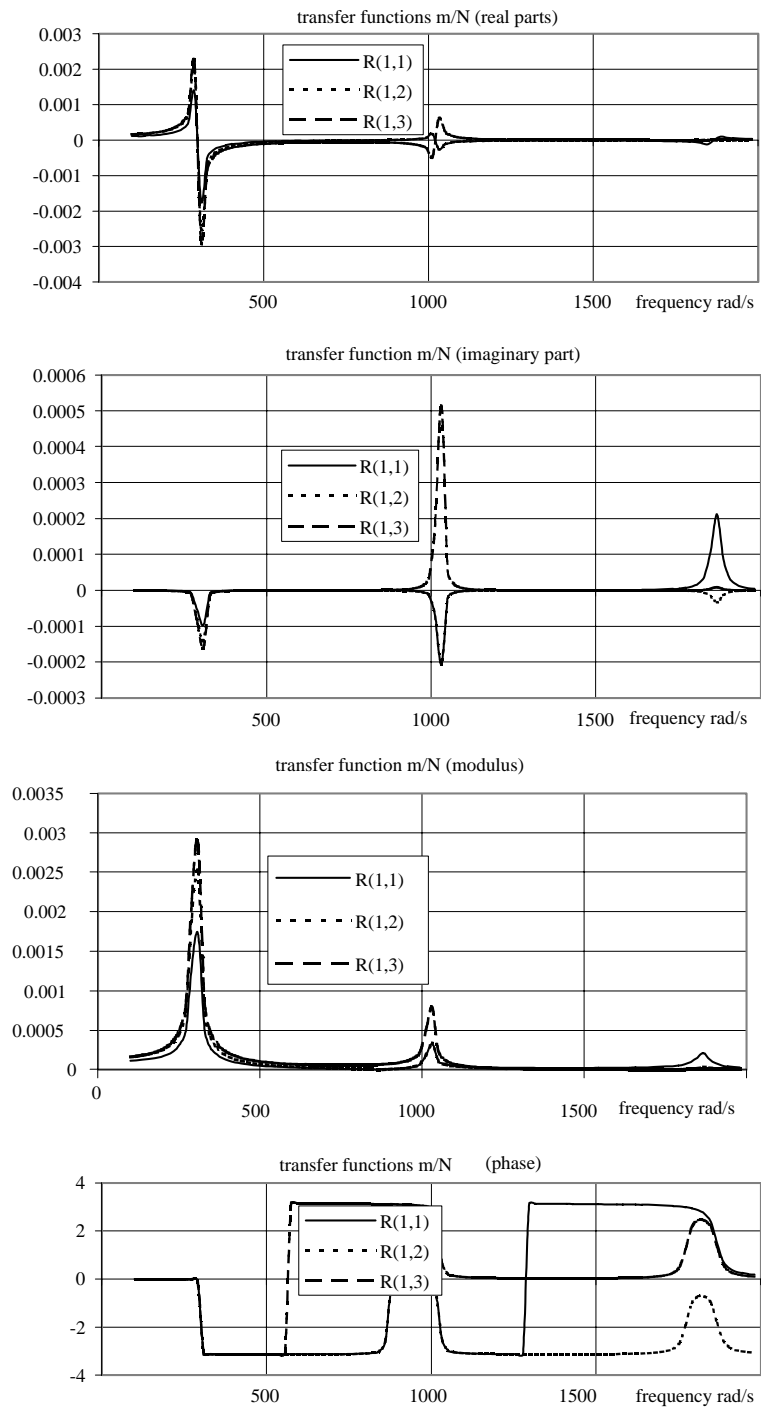

Figure 27

Experimental determination of the transfer functions

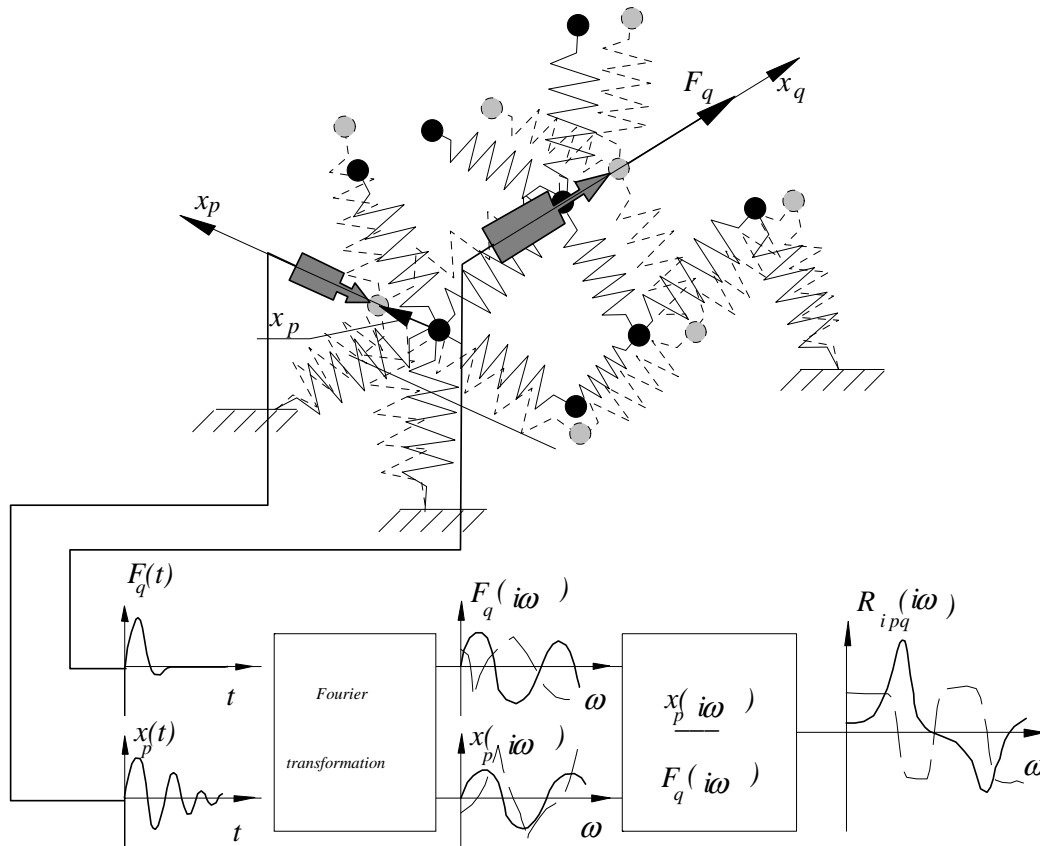

Figure 28

In order to produce the transfer function between the coordinate x_p and the coordinate x_q (see Fig. 28) let us apply force $F_q(t)$ along the coordinate x_q and record it simultaneously with the system response $x_p(t)$ along the coordinate x_p . *Fourier transformation* applied to these functions

$$\begin{aligned} F_q(i\omega) &= \int_{-\infty}^{+\infty} e^{-i\omega t} F_q(t) dt \\ x_p(i\omega) &= \int_{-\infty}^{+\infty} e^{-i\omega t} x_p(t) dt \end{aligned} \quad (2.97)$$

yields the *Fourier transforms* in the frequency domain $x_p(i\omega)$ and $F_q(i\omega)$. The amplitude of the complex functions $x_p(i\omega)$ and $F_q(i\omega)$

$$\begin{aligned} |x_p(i\omega)| &= \sqrt{\text{Re}(x_p(i\omega))^2 + \text{Im}(x_p(i\omega))^2} \\ |F_q(i\omega)| &= \sqrt{\text{Re}(F_q(i\omega))^2 + \text{Im}(F_q(i\omega))^2} \end{aligned} \quad (2.98)$$

represents the amplitude of displacement and force respectively as a function of the frequency ω . The corresponding phases are determined by the following formulae.

$$\begin{aligned}\varphi_{x_p} &= \arctan \frac{\text{Im}(x_p(i\omega))}{\text{Re}(x_p(i\omega))} \\ \varphi_{F_q} &= \arctan \frac{\text{Im}(F_q(i\omega))}{\text{Re}(F_q(i\omega))}\end{aligned}\quad (2.99)$$

These Fourier transforms allow the transfer function $R_{pq}(i\omega)$ to be computed.

$$R_{pq}(i\omega) = \frac{x_p(i\omega)}{F_q(i\omega)} \quad (2.100)$$

The above formula determines response of the system along coordinate x_p caused by the harmonic excitation F_q along the coordinate x_q .

$$x_p(i\omega) = R_{pq}(i\omega)F_q(i\omega) \quad (2.101)$$

Since the system considered is by assumption linear, the response along the coordinate x_p caused by set of forces acting along coordinates N coordinates x_q , according to the superposition principle, is

$$x_p(i\omega) = \sum_{q=1}^{q=N} R_{pq}(i\omega)F_q(i\omega) \quad q = 1 \dots N \quad (2.102)$$

Application of the above described experimental procedure to all coordinates involved in the modelling ($p = 1 \dots N$) allows to formulate the matrix of the transfer functions $\mathbf{R}_{pq}(i\omega)$. The relationship above can be rewritten in the following matrix form

$$\mathbf{x}(i\omega) = \mathbf{R}_{pq}(i\omega)\mathbf{F}(i\omega) \quad p = 1 \dots N, \quad q = 1 \dots N \quad (2.103)$$

2.2.2 Modal analysis - case of small damping

In the following analysis it will be assumed that the matrices \mathbf{m} , \mathbf{c} and \mathbf{k} are square and symmetrical. Size of these matrices is $N \times N$ where N is the number of the system degree of freedom. If the vector of the external excitation $\mathbf{F}(t)$ is equal to zero, it is said that the system performs free vibrations. According to the above definition the free vibrations are governed by the homogeneous set of equations

$$\mathbf{m}\ddot{\mathbf{x}} + \mathbf{c}\dot{\mathbf{x}} + \mathbf{k}\mathbf{x} = \mathbf{0} \quad (2.104)$$

Free vibration of the undamped system - eigenvalue and eigenvector problem

If the damping is neglected the equation of the free vibrations is

$$\mathbf{m}\ddot{\mathbf{x}} + \mathbf{k}\mathbf{x} = \mathbf{0} \quad (2.105)$$

It is easy to see that

$$\mathbf{x} = \mathbf{X} \cos \omega t \quad (2.106)$$

is a particular solution of the equation 2.105. Indeed, introduction of Eq. 2.106 into 2.105 yields

$$(-\omega^2 \mathbf{m} + \mathbf{k})\mathbf{X} \cos \omega t = \mathbf{0} \quad (2.107)$$

and the differential equation 2.105 is fulfilled for any instant of time if the following set of the homogeneous algebraic equations is fulfilled.

$$(-\omega^2 \mathbf{m} + \mathbf{k})\mathbf{X} = \mathbf{0} \quad (2.108)$$

In turn, the above set of equations has the non-zero solutions if and only if its characteristic determinant is equal to zero

$$|-\omega^2 \mathbf{m} + \mathbf{k}| = 0 \quad (2.109)$$

The above characteristic equation, for any physical system, has N positive roots with respect to the parameter ω^2 . Hence, the parameter ω can take any of the following values

$$\pm\omega_1, \quad \pm\omega_2, \quad \pm\omega_3, \quad \dots \pm\omega_n, \quad \dots \pm\omega_N \quad (2.110)$$

As one can see from Eq. 2.106, these parameters have the physical meaning only for positive values. They represent frequencies of the system free vibrations. They are called *natural frequencies*. The number of different natural frequencies is therefore equal to the number of degree of freedom. For each of the possible natural frequencies ω_n the system of equations 2.108 becomes linearly dependent and therefore has infinite number of solution \mathbf{X}_n . It follows that if \mathbf{X}_n is a solution of Eq. 2.108, the vector

$$C_n \mathbf{X}_n \quad (2.111)$$

where C_n is arbitrarily chosen constant, is solution of the Eq. 2.108 too. The vector \mathbf{X}_n represents so called *natural mode of vibration* associated with the natural

frequency ω_n . It determines the shape that the system must possess to oscillate harmonically with the frequency ω_n .

For example, if a beam with four concentrated masses is considered (see Fig. 29) the vector \mathbf{X}_n contains four numbers

$$\mathbf{X}_n = [X_{1n}, X_{2n}, X_{3n}, X_{4n}]^T \quad (2.112)$$

If the system is deflected according to the this vector and allowed to move with the

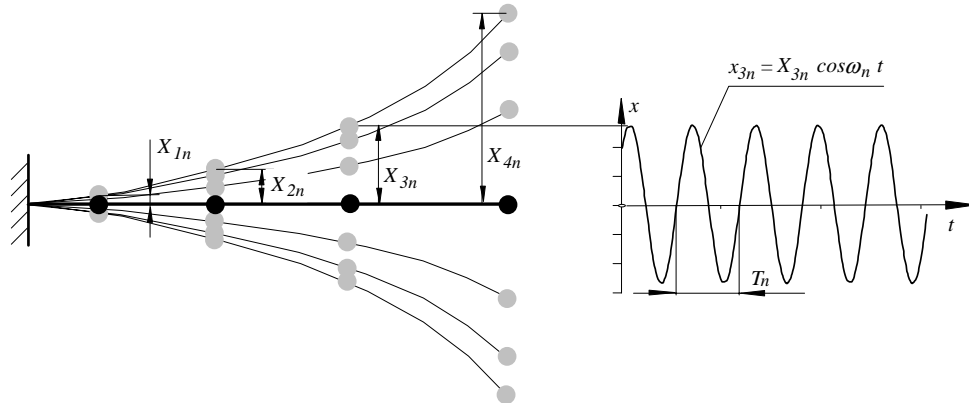

Figure 29

initial velocity equal to zero, it will oscillate with the frequency ω_n . There are four such a natural modes and four corresponding natural frequencies for this system.

The problem of the determination of the natural frequencies is called *eigenvalue problem* and searching for the corresponding natural modes is called *eigenvector problem*. Therefore the natural frequencies are very often referred to as *eigenvalue* and the natural modes as *eigenvectors*.

Now, one can say that the process of determination of the particular solution

$$\mathbf{x}_n = \mathbf{X}_n \cos \omega_n t \quad (2.113)$$

of the equation 2.105 has been accomplished. There are N such particular solutions.

In similar manner one can prove that

$$\mathbf{x}_n = \mathbf{X}_n \sin \omega_n t \quad (2.114)$$

is a particular solution too. Since the solutions ?? and 2.114 are linearly independent, their linear combination forms the general solution of the equation 2.105

$$\mathbf{x}_n = \sum_{n=1}^N (S_n \mathbf{X}_n \sin \omega_n t + C_n \mathbf{X}_n \cos \omega_n t) \quad (2.115)$$

The $2N$ constants S_n and C_n should be chosen to satisfy the $2N$ initial conditions.

Properties of the natural modes.

Each eigenvector has to fulfill the Eq. 2.108. Hence,

$$\begin{aligned} -\omega_n^2 \mathbf{m} \mathbf{X}_n + \mathbf{k} \mathbf{X}_n &= 0 \\ -\omega_m^2 \mathbf{m} \mathbf{X}_m + \mathbf{k} \mathbf{X}_m &= 0 \end{aligned} \quad (2.116)$$

Primultiplying the first equation by \mathbf{X}_m^T and the second equation by \mathbf{X}_n^T one can get

$$\begin{aligned} -\omega_n^2 \mathbf{X}_m^T \mathbf{m} \mathbf{X}_n + \mathbf{X}_m^T \mathbf{k} \mathbf{X}_n &= 0 \\ -\omega_m^2 \mathbf{X}_n^T \mathbf{m} \mathbf{X}_m + \mathbf{X}_n^T \mathbf{k} \mathbf{X}_m &= 0 \end{aligned} \quad (2.117)$$

Since matrices \mathbf{m} and \mathbf{k} are symmetrical

$$\mathbf{X}_m^T \mathbf{k} \mathbf{X}_n = \mathbf{X}_n^T \mathbf{k} \mathbf{X}_m \quad \text{and} \quad \mathbf{X}_m^T \mathbf{m} \mathbf{X}_n = \mathbf{X}_n^T \mathbf{m} \mathbf{X}_m \quad (2.118)$$

Now, primultiplying the first equation of set 2.117 by -1 and then adding them together we are getting

$$(\omega_n^2 - \omega_m^2) \mathbf{X}_n^T \mathbf{m} \mathbf{X}_m = 0 \quad (2.119)$$

Since for $n \neq m$ $(\omega_n^2 - \omega_m^2) \neq 0$,

$$\mathbf{X}_n^T \mathbf{m} \mathbf{X}_m = 0 \quad \text{for} \quad n \neq m \quad (2.120)$$

If $n = m$, since $(\omega_n^2 - \omega_n^2) = 0$, the product $\mathbf{X}_n^T \mathbf{m} \mathbf{X}_n$ does not have to be equal to zero. Let this product be equal to λ_n^2

$$\mathbf{X}_n^T \mathbf{m} \mathbf{X}_n = \lambda_n^2 \quad (2.121)$$

Division of the above equation by λ_n^2 yields

$$\left(\frac{1}{\lambda_n} \mathbf{X}_n^T \right) \mathbf{m} \left(\frac{1}{\lambda_n} \mathbf{X}_n \right) = 1 \quad (2.122)$$

But according to 2.111 $\frac{1}{\lambda_n} \mathbf{X}_n$ is eigenvector too. Let us denote it by $\mathbf{\Xi}_n$

$$\mathbf{\Xi}_n = \frac{1}{\lambda_n} \mathbf{X}_n \quad (2.123)$$

The process of producing of the eigenvectors $\mathbf{\Xi}_n$ is called *normalization* and the eigenvector $\mathbf{\Xi}_n$ is called *normalized eigenvector* or *normalized mode*. According to 2.122,

$$\mathbf{\Xi}_n^T \mathbf{m} \mathbf{\Xi}_n = 1 \quad (2.124)$$

Taking into account Eq's 2.120 and 2.124 one can conclude that

$$\mathbf{\Xi}_n^T \mathbf{m} \mathbf{\Xi}_m = \begin{cases} 0 & \text{if } n \neq m \\ 1 & \text{if } n = m \end{cases} \quad (2.125)$$

It is said that eigenvectors $\mathbf{\Xi}_n$ and $\mathbf{\Xi}_m$ that fulfill the above conditions are *orthogonal* with respect to the inertia matrix \mathbf{m} .

Owing to the above orthogonality condition, the second of the equations 2.117 yields

$$\mathbf{\Xi}_n^T \mathbf{k} \mathbf{\Xi}_m = \begin{cases} 0 & \text{if } n \neq m \\ \omega_n^2 & \text{if } n = m \end{cases} \quad (2.126)$$

It means that the normalized modes are orthogonal with respect to the matrix of stiffness.

The modal modes $\mathbf{\Xi}_n$ can be arranged in a square matrix of order N known as the *modal matrix* $\mathbf{\Xi}$.

$$\mathbf{\Xi} = [\mathbf{\Xi}_1, \mathbf{\Xi}_2, \dots, \mathbf{\Xi}_n, \dots, \mathbf{\Xi}_N] \quad \text{where } N \text{ is number of degrees of freedom} \quad (2.127)$$

It is easy to see that the developed orthogonality conditions yields

$$\begin{aligned} \mathbf{\Xi}^T \mathbf{m} \mathbf{\Xi} &= \mathbf{1} \\ \mathbf{\Xi}^T \mathbf{k} \mathbf{\Xi} &= \boldsymbol{\omega}^2 \end{aligned} \quad (2.128)$$

where $\boldsymbol{\omega}^2$ is a square diagonal matrix containing the squared natural frequencies ω_n^2

$$\boldsymbol{\omega}^2 = \begin{bmatrix} \omega_1^2 & 0 & \cdot & 0 & \cdot & 0 \\ 0 & \omega_2^2 & \cdot & 0 & \cdot & 0 \\ \cdot & \cdot & \cdot & \cdot & \cdot & \cdot \\ 0 & 0 & \cdot & \omega_n^2 & \cdot & 0 \\ \cdot & \cdot & \cdot & \cdot & \cdot & \cdot \\ 0 & 0 & \cdot & 0 & \cdot & \omega_N^2 \end{bmatrix} \quad (2.129)$$

Normal coordinates - modal damping

Motion of any real system is always associated with a dissipation of energy. Vibrations of any mechanical structures are coupled with deflections of the elastic elements. These deflections, in turn, cause friction between the particles the elements are made of. The damping caused by such an internal friction and damping due to friction of these elements against the surrounding medium is usually referred to as the structural damping. In many cases, particularly if the system considered is furnished with special devices design for dissipation of energy called dampers, the structural damping can be omitted. But in case of absence of such devices, the structural damping has to be taken into account. The structural damping is extremely difficult or simply impossible to be predicted by means of any analytical methods. In such cases the matrix of damping \mathbf{c} (see Eq. 2.104) is assumed as the following combination of the matrix of inertia \mathbf{m} and stiffness \mathbf{k} with the unknown coefficients μ and κ .

$$\mathbf{c} = \mu \mathbf{m} + \kappa \mathbf{k} \quad (2.130)$$

This coefficients are to be determined experimentally.

It will be shown that application of the following linear transformation

$$\mathbf{x} = \mathbf{\Xi} \boldsymbol{\eta} \quad (2.131)$$

to the mathematical model

$$\mathbf{m}\ddot{\mathbf{x}} + \mathbf{c}\dot{\mathbf{x}} + \mathbf{k}\mathbf{x} = \mathbf{F}(t) \quad (2.132)$$

results in its decoupling. Indeed, introduction of the transformation 2.131 into 2.132 yields

$$\mathbf{m}\Xi\ddot{\boldsymbol{\eta}} + \mathbf{c}\Xi\dot{\boldsymbol{\eta}} + \mathbf{k}\Xi\boldsymbol{\eta} = \mathbf{F}(t) \quad (2.133)$$

Primultiplying both sides of the above equation by Ξ^T we obtain

$$\Xi^T \mathbf{m}\Xi\ddot{\boldsymbol{\eta}} + \Xi^T(\mu\mathbf{m} + \kappa\mathbf{k})\Xi\dot{\boldsymbol{\eta}} + \Xi^T \mathbf{k}\Xi\boldsymbol{\eta} = \Xi^T \mathbf{F}(t) \quad (2.134)$$

Taking advantage of the orthogonality conditions 2.128 we are getting set of independent equations

$$\mathbf{1}\ddot{\boldsymbol{\eta}} + \boldsymbol{\gamma}\dot{\boldsymbol{\eta}} + \boldsymbol{\omega}_n^2\boldsymbol{\eta} = \Xi^T \mathbf{F}(t) \quad (2.135)$$

where

$\mathbf{1}$ - the unit matrix

$\boldsymbol{\omega}_n^2$ and $\boldsymbol{\gamma} = (\mu\mathbf{1} + \kappa\boldsymbol{\omega}_n^2)$ - diagonal matrices

Hence, each equation of the above set has the following form

$$\ddot{\eta}_n + 2\zeta_n\omega_n\dot{\eta}_n + \omega_n^2\eta_n = \Xi_n^T \mathbf{F}(t) \quad n = 1, 2, \dots, N \quad (2.136)$$

The coefficients $\zeta_n = (\mu + \kappa\omega_n^2)/2\omega_n$ are often referred to as the *modal damping ratio*.

Solution of each of the above equations can be obtained independently and according to the discussion carried out in the first chapter (page 30, Eq. 1.46) can be written as follows

$$\eta_n = e^{-\zeta_n\omega_n t} (C_{sn} \sin \omega_{dn} t + C_{cn} \cos \omega_{dn} t) + \eta_{pn} \quad (2.137)$$

where $\omega_{dn} = \omega_n \sqrt{1 - \zeta_n^2}$ and η_{pn} stands for the particular solution of the non-homogeneous equation 2.136. Problem of determination of this particular solution is considered in the next section.

Introduction of the solutions 2.137 into equation 2.131 yields motion of the system along the physical coordinates \mathbf{x} .

Response to the harmonic excitation - transfer functions

Let us solve the Eq. 2.136 for response of the system due to the harmonic excitation along coordinate x_q . In this case the right hand side of the equation 2.136 takes form

$$\Xi_n^T \mathbf{F}(t) = \Xi_n^T \begin{bmatrix} 0 \\ \cdot \\ F_q e^{i\omega t} \\ \cdot \\ 0 \end{bmatrix} = \Xi_{qn} F_q e^{i\omega t} \quad (2.138)$$

Hence

$$\ddot{\eta}_n + 2\zeta_n\omega_n\dot{\eta}_n + \omega_n^2\eta_n = \Xi_{qn} F_q e^{i\omega t} \quad n = 1, 2, \dots, N \quad (2.139)$$

Therefore

$$\eta_n = \frac{\Xi_{qn} F_q}{\omega_n^2 - \omega^2 + 2\zeta_n \omega_n \omega i} e^{i\omega t} \quad n = 1, 2, \dots, N \quad (2.140)$$

Since

$$\mathbf{x} = \Xi \boldsymbol{\eta} \quad (2.141)$$

response along coordinate x_p

$$x_p = e^{i\omega t} \sum_{n=1}^N \frac{\Xi_{pn} \Xi_{qn} F_q}{\omega_n^2 - \omega^2 + 2\zeta_n \omega_n \omega i} \quad (2.142)$$

transfer function between coordinate p and the others

$$\frac{x_p}{F_q e^{i\omega t}} = \sum_{n=1}^N \frac{\Xi_{pn} \Xi_{qn}}{\omega_n^2 - \omega^2 + 2\zeta_n \omega_n \omega i} \quad q = 1, 2, \dots, N \quad (2.143)$$

$$\begin{aligned} R_{pq}(i\omega) &= \frac{x_p}{F_q e^{i\omega t}} = \sum_{n=1}^N \frac{\Xi_{pn} \Xi_{qn} ((\omega_n^2 - \omega^2) - 2\zeta_n \omega_n \omega i)}{(\omega_n^2 - \omega^2)^2 + 4\zeta_n^2 \omega_n^2 \omega^2} = \\ &= \sum_{n=1}^N \left(\frac{\Xi_{pn} \Xi_{qn} (\omega_n^2 - \omega^2)}{(\omega_n^2 - \omega^2)^2 + 4\zeta_n^2 \omega_n^2 \omega^2} + \frac{-2\Xi_{pn} \Xi_{qn} \zeta_n \omega_n \omega i}{(\omega_n^2 - \omega^2)^2 + 4\zeta_n^2 \omega_n^2 \omega^2} \right) \quad q = 1, 2, \dots, N \end{aligned} \quad (2.144)$$

$$i.f \quad \omega \cong \omega_n \quad R_{pq}(i\omega) \cong \frac{\Xi_{pn} \Xi_{qn} (\omega_n^2 - \omega^2)}{4\zeta_n^2 \omega_n^2 \omega^2} + \frac{-\Xi_{pn} \Xi_{qn} i}{2\zeta_n \omega_n \omega} \quad q = 1, 2, \dots, N \quad (2.145)$$

Determination of natural frequencies and modes from the transfer functions

The transfer functions $R_{pq}(i\omega)$ can be easily obtained by means of a simple experiment (see page 100). They allow the natural frequencies, natural modes and the modal damping to be identified. It can be seen from the equation 2.145 that the real part of the transfer function $R_{pq}(i\omega)$ is equal to zero for the frequency equal to the natural frequency ω_n . Hence the zero-points of the real part of the transfer functions determine the system natural frequencies. From the same equation it is apparent that the imaginary parts corresponding to $\omega \cong \omega_n$ and measured for different $q = 1, 2, \dots, N$, but for the same p yield the natural modes with accuracy to the constant magnitude $C = -\frac{2\zeta_n \omega_n^2}{\Xi_{pn}}$

$$\Xi_{nq} = C \operatorname{Im}(R_{pq}(i\omega_n)) \quad q = 1, 2, \dots, N \quad (2.146)$$

Alternatively, The natural frequencies and the natural modes can be extracted from diagrams of the magnitudes and phases of the transfer function.

The phase φ , since the real part of the transfer function is equal to zero for $\omega = \omega_n$, is equal to $\pm 90^\circ$

$$\varphi_n = \arctan \frac{\operatorname{Im}(R_{pq}(i\omega_n))}{\operatorname{Re}(R_{pq}(i\omega_n))} = \pm \arctan \infty = \pm 90^\circ \quad (2.147)$$

This property allows the natural frequencies to be determined.

Since the real part of the transfer function is equal to zero for $\omega = \omega_n$, its modulus is equal to the absolute value of imaginary part.

$$|R_{pq}(i\omega)| = \left| \frac{\Xi_{pn}}{2\zeta_n\omega_n^2} \Xi_{qn} \right| \quad (2.148)$$

Hence

$$\Xi_{nq} = C |R_{pq}(i\omega)| \quad q = 1, 2, \dots, N \quad (2.149)$$

where

$$C = \left| \frac{2\zeta_n\omega_n^2}{\Xi_{pn}} \right| \quad (2.150)$$

Signe of the individual elements Ξ_{nq} of the mode n is deremined by signe of the corresponding phase $\varphi_n = \pm 90^\circ$

An example of extracting the natural frequency and the corresponding natural mode from the transfer functions is shown in Fig. 30

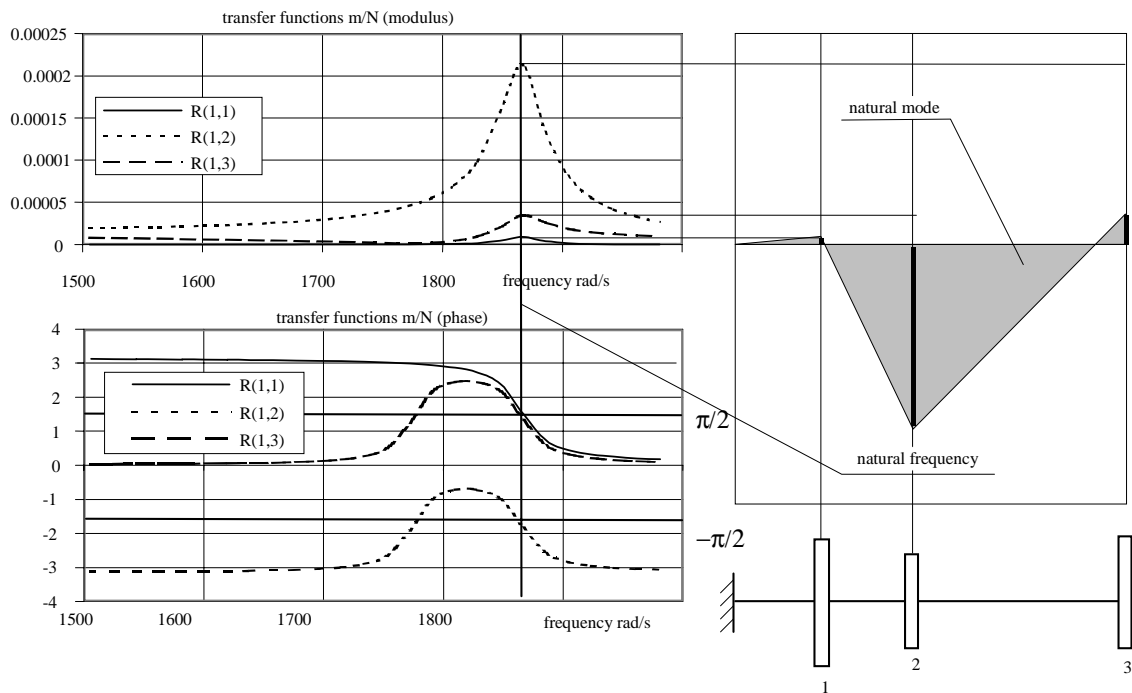

Figure 30

The demonstated in this chapter approach for solution of the vibration problems is referred to as *modal analysis*.

2.2.3 Kinetic and potential energy functions - Dissipation function

In this section the kinetic energy function, the potential energy function and the dissipation function are formulated for a linear system governed by the equation

$$\mathbf{m}\ddot{\mathbf{x}} + \mathbf{c}\dot{\mathbf{x}} + \mathbf{k}\mathbf{x} = \mathbf{F}(t) \quad (2.151)$$

where the matrices \mathbf{m} , \mathbf{c} and \mathbf{k} are symmetric and positive definite matrices.

Kinetic energy function

Let us consider function

$$T = \frac{1}{2} \dot{\mathbf{x}}^T \mathbf{m} \dot{\mathbf{x}} \quad \dot{\mathbf{x}} = \{\dot{x}_1, \dots, \dot{x}_n, \dots, \dot{x}_N\}^T \quad (2.152)$$

Performing the matrix multiplication we are getting

$$\begin{aligned} T &= \frac{1}{2} \{\dot{x}_1, \dots, \dot{x}_n, \dots, \dot{x}_N\} \left\{ \begin{array}{c} \sum_{m=1}^{m=N} m_{1m} \dot{x}_m \\ \dots \dots \dots \\ \sum_{m=1}^{m=N} m_{nm} \dot{x}_m \\ \dots \dots \dots \\ \sum_{m=1}^{m=N} m_{Nm} \dot{x}_m \end{array} \right\} = \frac{1}{2} \sum_{n=1}^{n=N} \left(\dot{x}_n \sum_{m=1}^{m=N} m_{nm} \dot{x}_m \right) \quad (2.153) \\ &= \frac{1}{2} \sum_{n=1}^{n=N} \sum_{m=1}^{m=N} m_{nm} \dot{x}_n \dot{x}_m \end{aligned}$$

If this function is *positive definite* (is always positive and is equal to zero if and only if all variables \dot{x}_n are equal to zero) the corresponding matrix \mathbf{m} is called *positive definite matrix*.

If T is the kinetic energy function, according to Lagrange's equations should be

$$\frac{d}{dt} \left(\frac{\partial T}{\partial \dot{x}_n} \right) - \frac{\partial T}{\partial x_n} = \{m_{n1}, \dots, m_{nn}, \dots, m_{nN}\} \left\{ \begin{array}{c} \ddot{x}_1 \\ \dots \\ \ddot{x}_n \\ \dots \\ \ddot{x}_N \end{array} \right\} \quad (2.154)$$

Let us prove that the function 2.152 fulfills the requirement 2.154.

$$\begin{aligned} &\frac{d}{dt} \left(\frac{\partial T}{\partial \dot{x}_n} \right) - \frac{\partial T}{\partial x_n} \\ &= \frac{d}{dt} \left(\frac{1}{2} \left(\{0, 0, \dots, 1, \dots, 0\} \left\{ \begin{array}{c} \sum_{m=1}^{m=N} m_{1m} \dot{x}_m \\ \dots \dots \dots \\ \sum_{m=1}^{m=N} m_{nm} \dot{x}_m \\ \dots \dots \dots \\ \sum_{m=1}^{m=N} m_{Nm} \dot{x}_m \end{array} \right\} + \{\dot{x}_1, \dots, \dot{x}_n, \dots, \dot{x}_N\} \left\{ \begin{array}{c} m_{1n} \\ \dots \\ m_{nn} \\ \dots \\ m_{Nn} \end{array} \right\} \right) \right) = \\ &= \frac{d}{dt} \left(\frac{1}{2} \left(\sum_{m=1}^{m=N} m_{nm} \dot{x}_m + \sum_{m=1}^{m=N} m_{mn} \dot{x}_m \right) \right) \quad (2.155) \end{aligned}$$

Since $m_{nm} = m_{mn}$

$$\begin{aligned} \frac{d}{dt} \left(\frac{\partial T}{\partial \dot{x}_n} \right) - \frac{\partial T}{\partial x_n} &= \frac{d}{dt} \left(\frac{1}{2} \sum_{m=1}^{m=N} m_{nm} \dot{x}_m \right) = \frac{d}{dt} \left(\sum_{m=1}^{m=N} m_{nm} \dot{x}_m \right) \\ &= \sum_{m=1}^{m=N} m_{nm} \ddot{x}_m = \{m_{n1}, \dots, m_{nn}, \dots, m_{nN}\} \begin{Bmatrix} \ddot{x}_1 \\ \dots \\ \ddot{x}_n \\ \dots \\ \ddot{x}_N \end{Bmatrix} \end{aligned} \quad (2.156)$$

Now we may conclude that the function 2.152 is the kinetic energy function if the matrix \mathbf{m} is symmetric and positive definite.

Potential energy function

Let us consider function

$$V = \frac{1}{2} \mathbf{x}^T \mathbf{k} \mathbf{x} \quad \mathbf{x} = \{x_1, \dots, x_n, \dots, x_N\}^T \quad (2.157)$$

Performing the matrix multiplication we are getting

$$\begin{aligned} V &= \frac{1}{2} \{x_1, x_2, \dots, x_n, \dots, x_N\} \begin{Bmatrix} \sum_{m=1}^{m=N} k_{1m} x_m \\ \dots \\ \sum_{m=1}^{m=N} k_{nm} x_m \\ \dots \\ \sum_{m=1}^{m=N} k_{Nm} x_m \end{Bmatrix} = \frac{1}{2} \sum_{n=1}^{n=N} \left(x_n \sum_{m=1}^{m=N} k_{nm} x_m \right) \\ &= \frac{1}{2} \sum_{n=1}^{n=N} \sum_{m=1}^{m=N} k_{nm} x_n x_m \end{aligned} \quad (2.158)$$

If V is the potential energy function, it must be positive definite and according to Lagrange's equations should fulfill the following relationship

$$\frac{\partial V}{\partial x_n} = \{k_{n1}, \dots, k_{nn}, \dots, k_{nN}\} \begin{Bmatrix} x_1 \\ \dots \\ x_n \\ \dots \\ x_N \end{Bmatrix} \quad (2.159)$$

Let us prove that the function 2.157 fulfills the requirement 2.159.

$$\begin{aligned} \frac{\partial V}{\partial x_n} &= \frac{1}{2} \left(\{0, 0, \dots, 1, \dots, 0\} \begin{Bmatrix} \sum_{m=1}^{m=N} k_{1m} x_m \\ \dots \\ \sum_{m=1}^{m=N} k_{nm} x_m \\ \dots \\ \sum_{m=1}^{m=N} k_{Nm} x_m \end{Bmatrix} + \{x_1, \dots, x_n, \dots, x_N\} \begin{Bmatrix} k_{1n} \\ \dots \\ k_{nn} \\ \dots \\ k_{Nn} \end{Bmatrix} \right) \\ &= \frac{1}{2} \left(\sum_{m=1}^{m=N} k_{nm} x_m + \sum_{m=1}^{m=N} k_{mn} x_m \right) \end{aligned} \quad (2.160)$$

Since $k_{nm} = k_{mn}$

$$\frac{\partial V}{\partial x_n} = \frac{1}{2} 2 \sum_{m=1}^{m=N} k_{nm} x_m = \sum_{m=1}^{m=N} k_{nm} x_m = \{k_{n1}, \dots, k_{nn}, \dots, k_{nN}\} \begin{Bmatrix} x_1 \\ \dots \\ x_n \\ \dots \\ x_N \end{Bmatrix} \quad (2.161)$$

Now we may conclude that the function 2.157 is the kinetic energy function if the matrix \mathbf{k} is symmetric and positive definite.

Dissipation function

It is easy to notice, having in mind the previous consideration, that the function

$$D = \frac{1}{2} \dot{\mathbf{x}}^T \mathbf{c} \dot{\mathbf{x}} \quad \dot{\mathbf{x}} = \{\dot{x}_1, \dots, \dot{x}_n, \dots, \dot{x}_N\}^T \quad (2.162)$$

fulfills the following relationship

$$\frac{\partial D}{\partial \dot{x}_n} = \{c_{n1}, \dots, c_{nn}, \dots, c_{nN}\} \begin{Bmatrix} \dot{x}_1 \\ \dots \\ \dot{x}_n \\ \dots \\ \dot{x}_N \end{Bmatrix} \quad (2.163)$$

It follows that if the matrix of damping is symmetrical and positive definite, such a damping can be included in the Lagrange's equation in the following way

$$\frac{d}{dt} \left(\frac{\partial T}{\partial \dot{x}_n} \right) - \frac{\partial T}{\partial x_n} + \frac{\partial V}{\partial x_n} + \frac{\partial D}{\partial \dot{x}_n} = Q_n \quad (2.164)$$

The function D is called dissipation function. **It must be noted that the dissipation function does not represent the dissipation energy.**

The damping forces, in a general case, are not conservative and have to be included in the generalized force Q_n .

2.2.4 Problems

Problem 29

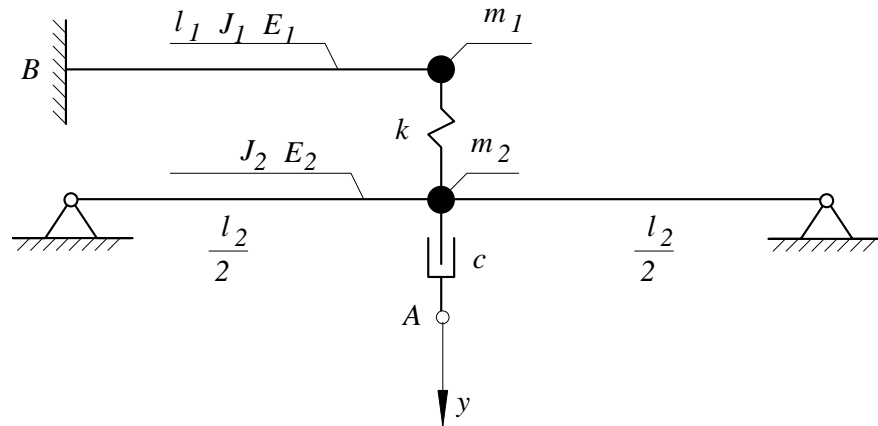

Figure 31

The point A of the system shown in Fig. 31 moves according to the following equation

$$y = A_1 \sin(f_1 t) + A_2 \sin(f_2 t) \quad (2.165)$$

where A_1 and A_2 are amplitudes of this motion and f_1 and f_2 are the corresponding frequencies.

Produce

1. the differential equations of motion
2. the natural frequencies
3. the steady state motion of the system due to the kinematic excitation y
4. the exciting force at the point A required to maintain the steady state motion
5. the reaction force and the reaction moment at the point B .

Given are:

$$l_1 = 1\text{m} \quad E_1 = 0.2 \cdot 10^{12}\text{N/m}^2 \quad J_1 = 1 \cdot 10^{-8}\text{m}^4 \quad m_1 = 10\text{kg}$$

$$l_2 = 2\text{m} \quad E_2 = 0.2 \cdot 10^{12}\text{N/m}^2 \quad J_2 = 1 \cdot 10^{-8}\text{m}^4 \quad m_2 = 20\text{kg}$$

$$k = 10000\text{N/m}$$

$$c = 100\text{Ns/m}$$

$$A_1 = 0.01\text{m} \quad f_1 = 30\text{rad/s}$$

$$A_2 = 0.01\text{m} \quad f_2 = 35\text{rad/s}$$

Solution

1. The differential equations of motion

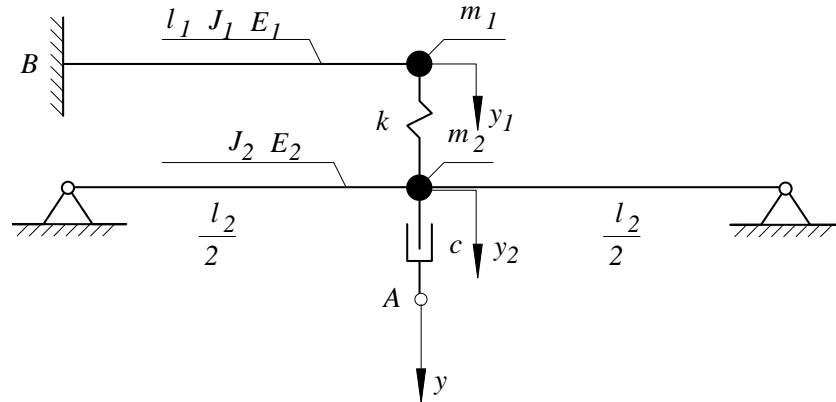

Figure 32

Utilization of the Newton-Euler approach for modelling of the system shown in Fig. 32 allows to develop its mathematical model.

$$\begin{aligned} m_1 \ddot{y}_1 &= -k_1 y_1 - k y_1 + k y_2 \\ m_2 \ddot{y}_2 &= -k_2 y_2 - k y_2 + k y_1 - c \dot{y}_2 + c \dot{y} \end{aligned} \quad (2.166)$$

Its matrix form is

$$\begin{bmatrix} m_1 & \\ & m_2 \end{bmatrix} \begin{bmatrix} \ddot{y}_1 \\ \ddot{y}_2 \end{bmatrix} + \begin{bmatrix} 0 & \\ & c \end{bmatrix} \begin{bmatrix} \dot{y}_1 \\ \dot{y}_2 \end{bmatrix} + \begin{bmatrix} k + k_1 & -k \\ -k & k + k_2 \end{bmatrix} \begin{bmatrix} y_1 \\ y_2 \end{bmatrix} = \begin{bmatrix} 0 \\ c \dot{y} \end{bmatrix} \quad (2.167)$$

or shorter

$$\mathbf{m} \ddot{\mathbf{y}} + \mathbf{c} \dot{\mathbf{y}} + \mathbf{k} \mathbf{y} = \mathbf{F}(t) \quad (2.168)$$

where

$$\mathbf{m} = \begin{bmatrix} m_1 & 0 \\ 0 & m_2 \end{bmatrix}; \quad \mathbf{c} = \begin{bmatrix} 0 & 0 \\ 0 & c \end{bmatrix}; \quad \mathbf{k} = \begin{bmatrix} k + k_1 & -k \\ -k & k + k_2 \end{bmatrix}; \quad \mathbf{F}(t) = \begin{bmatrix} 0 \\ c \dot{y} \end{bmatrix} \quad (2.169)$$

Taking into consideration Eq. 2.165, the excitation $c \dot{y}$ is

$$c \dot{y} = c A_1 f_1 \cos(f_1 t) + c A_2 f_2 \cos(f_2 t) = a_1 \cos(f_1 t) + a_2 \cos(f_2 t) \quad (2.170)$$

where

$$a_1 = c A_1 f_1; \quad a_2 = c A_2 f_2$$

Introduction of Eq. 2.170 into the equation of motion 2.168 yields

$$\mathbf{m} \ddot{\mathbf{y}} + \mathbf{c} \dot{\mathbf{y}} + \mathbf{k} \mathbf{y} = \mathbf{F}_1(t) + \mathbf{F}_2(t) \quad (2.171)$$

where

$$\mathbf{F}_1(t) = \begin{bmatrix} 0 \\ a_1 \cos(f_1 t) \end{bmatrix}; \quad \mathbf{F}_2(t) = \begin{bmatrix} 0 \\ a_2 \cos(f_2 t) \end{bmatrix} \quad (2.172)$$

For the given numerical data the stiffness of the beam 1 at the point of attachment of the mass 1 is

$$k_1 = \frac{3E_1 J_1}{l_1^3} = \frac{3 \cdot 0.2 \cdot 10^{12} \cdot 1 \cdot 10^{-8}}{1^3} = 6000 \text{ N/m} \quad (2.173)$$

The stiffness of the beam 2 at the point of attachment of the mass 2 is

$$k_2 = \frac{48E_2 J_2}{l_2^3} = \frac{48 \cdot 0.2 \cdot 10^{12} \cdot 1 \cdot 10^{-8}}{2^3} = 12000 \text{ N/m} \quad (2.174)$$

Hence

$$\mathbf{m} = \begin{bmatrix} 10 & 0 \\ 0 & 20 \end{bmatrix}; \quad \mathbf{c} = \begin{bmatrix} 0 & 0 \\ 0 & 100 \end{bmatrix}; \quad \mathbf{k} = \begin{bmatrix} 16000 & -10000 \\ -10000 & 22000 \end{bmatrix} \quad (2.175)$$

$$\mathbf{F}_1(t) = \begin{bmatrix} 0 \\ 30 \cos(30t) \end{bmatrix}; \quad \mathbf{F}_2(t) = \begin{bmatrix} 0 \\ 35 \cos(35t) \end{bmatrix}$$

2. Free motion - the natural frequencies

To analyze the free vibrations let us transfer the homogeneous equation 2.171 to the state-space coordinates. The substitution

$$\mathbf{w} = \dot{\mathbf{y}} \quad (2.176)$$

results in the following set of equations

$$\dot{\mathbf{z}} = \mathbf{A}\mathbf{z} \quad (2.177)$$

where

$$\mathbf{z} = \begin{bmatrix} \mathbf{y} \\ \mathbf{w} \end{bmatrix}, \quad \mathbf{A} = \begin{bmatrix} \mathbf{0} & \mathbf{1} \\ -\mathbf{m}^{-1}\mathbf{k} & -\mathbf{m}^{-1}\mathbf{c} \end{bmatrix} = \begin{bmatrix} 0 & 0 & 1 & 0 \\ 0 & 0 & 0 & 1 \\ -1600.0 & 1000 & 0 & 0 \\ 500 & -1100 & 0 & -5 \end{bmatrix} \quad (2.178)$$

Solution of the eigenvalue problem yields the following complex roots

$$\begin{aligned} \omega_1 &= -1.6741 \pm 24.483i \\ \omega_2 &= -0.8259 \pm 45.734i \end{aligned} \quad (2.179)$$

For underdamped system the imaginary part of the above roots represents the natural frequency of the damped system. The real part indicates the rate of decay of the free vibrations.

Solution of the eigenvector problem produces the following complex vectors.

$$\begin{aligned} \operatorname{Re} \mathbf{z}_{01} &= \begin{bmatrix} -1.6392 \times 10^{-2} \\ -1.7637 \times 10^{-2} \\ .38263 \\ .35302 \end{bmatrix}, & \operatorname{Im} \mathbf{z}_{01} &= \begin{bmatrix} -1.4508 \times 10^{-2} \\ -1.3213 \times 10^{-2} \\ -.37705 \\ -.40969 \end{bmatrix} \\ \operatorname{Re} \mathbf{z}_{02} &= \begin{bmatrix} 1.9755 \times 10^{-2} \\ -1.0154 \times 10^{-2} \\ .26033 \\ -5.9162 \times 10^{-2} \end{bmatrix}, & \operatorname{Im} \mathbf{z}_{02} &= \begin{bmatrix} -6.049 \times 10^{-3} \\ 1.477 \times 10^{-3} \\ .90847 \\ -.46561 \end{bmatrix} \end{aligned} \quad (2.180)$$

According to 2.81, the particular solutions are

$$\begin{aligned} \mathbf{z}_{11} &= e^{h_1 t} (\operatorname{Re}(\mathbf{z}_{01}) \cos \omega_1 t - \operatorname{Im}(\mathbf{z}_{01}) \sin \omega_1 t) = \\ &= e^{-1.6741t} \left(\begin{bmatrix} -1.6392 \times 10^{-2} \\ -1.7637 \times 10^{-2} \\ .38263 \\ .35302 \end{bmatrix} \cos 24.483t - \begin{bmatrix} -1.4508 \times 10^{-2} \\ -1.3213 \times 10^{-2} \\ -.37705 \\ -.40969 \end{bmatrix} \sin 24.483t \right) \\ \mathbf{z}_{12} &= e^{h_1 t} (\operatorname{Re}(\mathbf{z}_{01}) \sin \omega_1 t + \operatorname{Im}(\mathbf{z}_{01}) \cos \omega_1 t) = \\ &= e^{-1.6741t} \left(\begin{bmatrix} -1.6392 \times 10^{-2} \\ -1.7637 \times 10^{-2} \\ .38263 \\ .35302 \end{bmatrix} \sin 24.483t + \begin{bmatrix} -1.4508 \times 10^{-2} \\ -1.3213 \times 10^{-2} \\ -.37705 \\ -.40969 \end{bmatrix} \cos 24.483t \right) \\ \mathbf{z}_{21} &= e^{h_2 t} (\operatorname{Re}(\mathbf{z}_{02}) \cos \omega_2 t - \operatorname{Im}(\mathbf{z}_{02}) \sin \omega_2 t) = \\ &= e^{-0.8259t} \left(\begin{bmatrix} 1.9755 \times 10^{-2} \\ -1.0154 \times 10^{-2} \\ .26033 \\ -5.9162 \times 10^{-2} \end{bmatrix} \cos 45.734t - \begin{bmatrix} -6.049 \times 10^{-3} \\ 1.477 \times 10^{-3} \\ .90847 \\ -.46561 \end{bmatrix} \sin 45.734t \right) \\ \mathbf{z}_{22} &= e^{h_2 t} (\operatorname{Re}(\mathbf{z}_{02}) \sin \omega_2 t + \operatorname{Im}(\mathbf{z}_{02}) \cos \omega_2 t) = \\ &= e^{-0.8259t} \left(\begin{bmatrix} 1.9755 \times 10^{-2} \\ -1.0154 \times 10^{-2} \\ .26033 \\ -5.9162 \times 10^{-2} \end{bmatrix} \sin 45.734t + \begin{bmatrix} -6.049 \times 10^{-3} \\ 1.477 \times 10^{-3} \\ .90847 \\ -.46561 \end{bmatrix} \cos 45.734t \right) \end{aligned} \quad (2.181)$$

The two first rows in the above solutions represent displacement along the coordinates y_1 and y_2 respectively. The two last rows represents the generalized velocities along the coordinates y_1 and y_2 . Example of the motion along the coordinate y_1 , associated with the particular solution \mathbf{z}_{11} (y_{111}) and \mathbf{z}_{21} (y_{211})

$$\begin{aligned} y_{111} &= e^{-1.6741t} (-1.6392 \times 10^{-2} \cos 24.483t + 1.4508 \times 10^{-2} \sin 24.483t) \\ y_{211} &= e^{-0.8259t} (1.9755 \times 10^{-2} \cos 45.734t + 6.049 \times 10^{-3} \sin 45.734t) \end{aligned} \quad (2.182)$$

are presented in Fig 33.

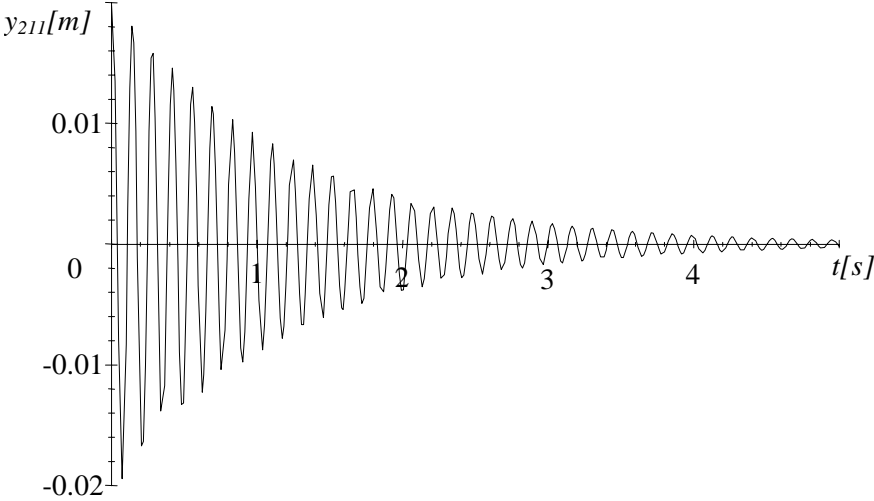
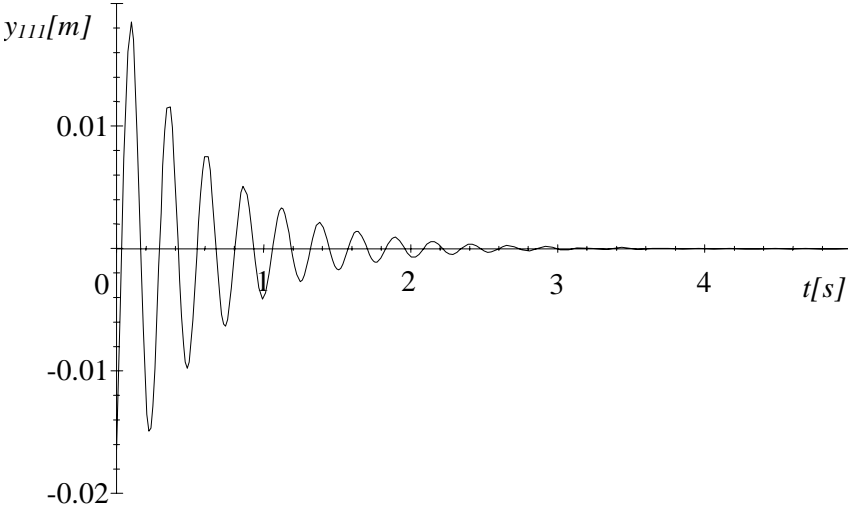

Figure 33

3. The steady state motion of the system due to the kinematic excitation

According to the given data, motion of the point A is

$$y = 0.01 \cdot \sin(30 \cdot t) + 0.01 \cdot \sin(35 \cdot t) \quad (2.183)$$

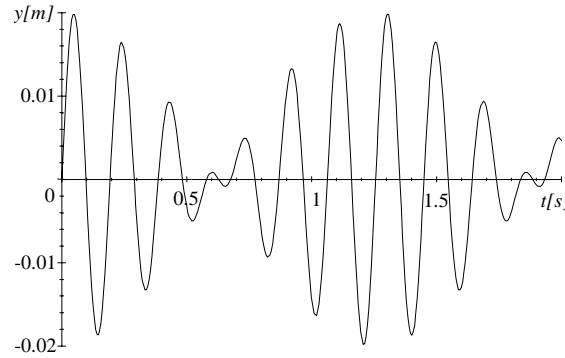

Figure 34

The time history diagram of this motion is given in Fig. 34

The particular solution \mathbf{y} , which represents the forced vibration, according to the superposition rule, is

$$\mathbf{y} = \mathbf{y}_1 + \mathbf{y}_2 \quad (2.184)$$

where \mathbf{y}_1 is the particular solution of the equation 2.185

$$\mathbf{m}\ddot{\mathbf{y}} + \mathbf{c}\dot{\mathbf{y}} + \mathbf{k}\mathbf{y} = \mathbf{F}_1(t) \quad (2.185)$$

and \mathbf{y}_2 is the particular solution of the equation 2.186

$$\mathbf{m}\ddot{\mathbf{y}} + \mathbf{c}\dot{\mathbf{y}} + \mathbf{k}\mathbf{y} = \mathbf{F}_2(t) \quad (2.186)$$

To produce the particular solution of the equation 2.185 let us introduce the complex excitation

$$\begin{aligned} \mathbf{F}_1^c(t) &= \begin{bmatrix} 0 \\ a_1 \cos(f_1 t) + ia_1 \sin(f_1 t) \end{bmatrix} = \begin{bmatrix} 0 \\ a_1 e^{if_1 t} \end{bmatrix} = \begin{bmatrix} 0 \\ a_1 \end{bmatrix} e^{if_1 t} = \\ &= \mathbf{F}_{10} e^{if_1 t} = \begin{bmatrix} 0 \\ 30 \end{bmatrix} e^{i30t} \end{aligned} \quad (2.187)$$

Hence the equation of motion takes form

$$\mathbf{m}\ddot{\mathbf{y}} + \mathbf{c}\dot{\mathbf{y}} + \mathbf{k}\mathbf{y} = \mathbf{F}_{10} e^{if_1 t} \quad (2.188)$$

Its particular solution is

$$\mathbf{y}_1^c = \mathbf{y}_{10}^c e^{if_1 t} \quad (2.189)$$

where

$$\begin{aligned}
 \mathbf{y}_{10}^c &= (-f_1^2 \mathbf{m} + i f_1 \mathbf{c} + \mathbf{k})^{-1} \mathbf{F}_{10} = \\
 &= \left(-30^2 \begin{bmatrix} 10 & 0 \\ 0 & 20 \end{bmatrix} + 30i \begin{bmatrix} 0 & 0 \\ 0 & 100 \end{bmatrix} + \begin{bmatrix} 16000 & -10000 \\ -10000 & 22000 \end{bmatrix} \right)^{-1} \begin{bmatrix} 0 \\ 30 \end{bmatrix} = \\
 &= \begin{bmatrix} -.00384 - .00112i \\ -2.688 \times 10^{-3} - 7.84 \times 10^{-4}i \end{bmatrix} \quad (2.190)
 \end{aligned}$$

The motion of the system, as the real part of 2.189 is

$$\begin{aligned}
 \mathbf{y}_1 &= \text{Re} \left(\begin{bmatrix} -.00384 - .00112i \\ -2.688 \times 10^{-3} - 7.84 \times 10^{-4}i \end{bmatrix} e^{i30t} \right) \\
 &= \begin{bmatrix} -.00384 \cos 30t + .00112 \sin 30t \\ -2.688 \times 10^{-3} \cos 30t + 7.84 \times 10^{-4} \sin 30t \end{bmatrix}
 \end{aligned}$$

Similarly, one can obtain motion due to the excitation $\mathbf{F}_2(t)$

$$\begin{aligned}
 \mathbf{y}_{20}^c &= (-f_2^2 \mathbf{m} + i f_2 \mathbf{c} + \mathbf{k})^{-1} \mathbf{F}_{20} = \\
 &= \left(-35^2 \begin{bmatrix} 10 & 0 \\ 0 & 20 \end{bmatrix} + 35i \begin{bmatrix} 0 & 0 \\ 0 & 100 \end{bmatrix} + \begin{bmatrix} 16000 & -10000 \\ -10000 & 22000 \end{bmatrix} \right)^{-1} \begin{bmatrix} 0 \\ 35 \end{bmatrix} = \\
 &= \begin{bmatrix} -3.1546 \times 10^{-3} - 3.7855 \times 10^{-4}i \\ -1.183 \times 10^{-3} - 1.4196 \times 10^{-4}i \end{bmatrix} \quad (2.191)
 \end{aligned}$$

Hence

$$\begin{aligned}
 \mathbf{y}_2 &= \text{Re} \left(\begin{bmatrix} -3.1546 \times 10^{-3} - 3.7855 \times 10^{-4}i \\ -1.183 \times 10^{-3} - 1.4196 \times 10^{-4}i \end{bmatrix} e^{i35t} \right) \\
 &= \begin{bmatrix} -3.1546 \times 10^{-3} \cos 35t + 3.7855 \times 10^{-4} \sin 35t \\ -1.183 \times 10^{-3} \cos 35t + 1.4196 \times 10^{-4} \sin 35t \end{bmatrix} \quad (2.192)
 \end{aligned}$$

The resultant motion of the system due to both components of excitation is

$$\begin{aligned}
 \mathbf{y} &= \mathbf{y}_1 + \mathbf{y}_2 \\
 &= \begin{bmatrix} -.00384 \cos 30t + .00112 \sin 30t \\ -2.688 \times 10^{-3} \cos 30t + 7.84 \times 10^{-4} \sin 30t \end{bmatrix} + \\
 &\quad + \begin{bmatrix} -3.1546 \times 10^{-3} \cos 35t + 3.7855 \times 10^{-4} \sin 35t \\ -1.183 \times 10^{-3} \cos 35t + 1.4196 \times 10^{-4} \sin 35t \end{bmatrix} \\
 &= \begin{bmatrix} -.0038 \cos 30t + .0011 \sin 30t - 3.15 \times 10^{-3} \cos 35t + 3.78 \times 10^{-4} \sin 35t \\ -2.6 \times 10^{-3} \cos 30t + 7.8 \times 10^{-4} \sin 30t - 1.1 \times 10^{-3} \cos 35t + 1.41 \times 10^{-4} \sin 35t \end{bmatrix} \quad (2.193)
 \end{aligned}$$

This resultant motion of the system along the coordinates y_1 and y_2 , computed according to the equation 2.193, is shown in Fig. 35 and 36 respectively.

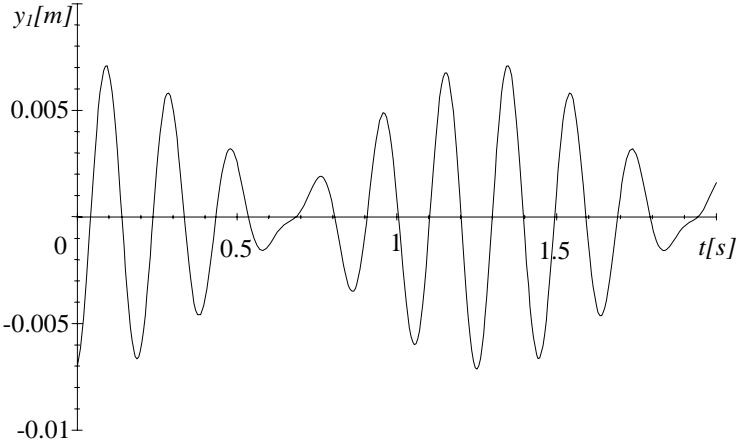

Figure 35

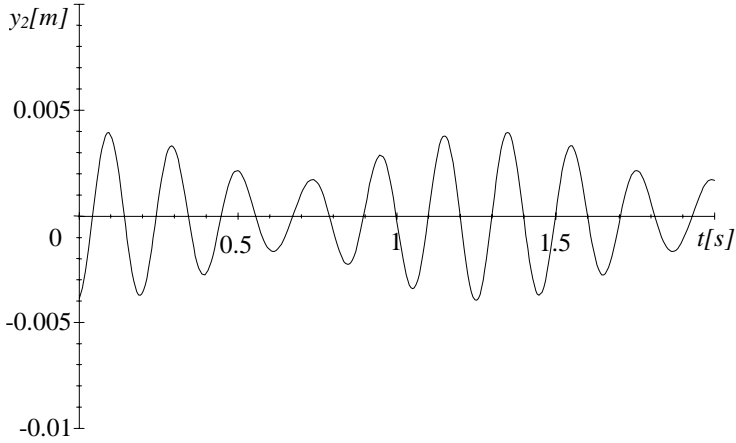

Figure 36

4. The exciting force at the point A required to maintain the steady state motion

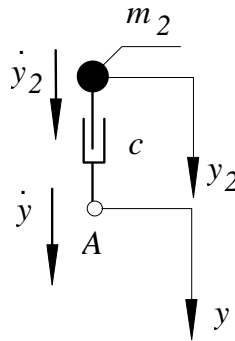

Figure 37

To develop the expression for the force necessary to move the point A according to the assumed motion 2.183, let us consider the damper c shown in Fig. 37. If the point A moves with the velocity \dot{y} and in the same time the mass m_2 moves with the velocity \dot{y}_2 , the relative velocity of the point A with respect to the mass m_2 is

$$v = \dot{y} - \dot{y}_2 \quad (2.194)$$

Therefore, to realize this motion, it is necessary to apply at the point A the following force

$$F_A = c(\dot{y} - \dot{y}_2) \quad (2.195)$$

Hence, according to the equation 2.183 and 2.193 we have

$$\begin{aligned} F_A &= 100 \left(\frac{d}{dt} (0.01 \cdot \sin 30t + 0.01 \cdot \sin 35t) + \right. \\ &\quad \left. - \frac{d}{dt} (-2.6 \cdot 10^{-3} \cos 30t + 7.8 \cdot 10^{-4} \sin 30t + \right. \\ &\quad \left. -1.1 \cdot 10^{-3} \cos 35t + 1.4 \cdot 10^{-4} \sin 35t) \right) = \\ &= 27.648 \cos 30t + 34.503 \cos 35t - 8.064 \sin 30t - 4.1405 \sin 35t [N] \end{aligned} \quad (2.196)$$

Diagram of this force is presented in Fig.38

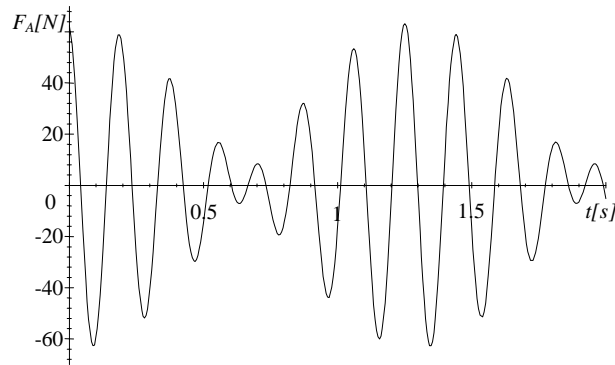

Figure 38

5. The reaction force and the reaction moment at the point B .

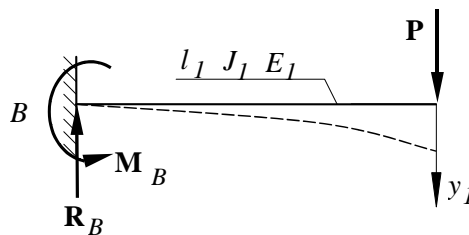

Figure 39

According to Fig. 39

$$\begin{aligned} R_B &= P \\ M_B &= Pl_1 \end{aligned} \quad (2.197)$$

where P is dependent on the instantaneous displacement y_1 . This relationship is determined by the formula 2.173

$$P = k_1 y_1 = \frac{3E_1 J_1}{l_1^3} y_1 = \frac{3 \cdot 0.2 \cdot 10^{12} \cdot 1 \cdot 10^{-8}}{1^3} = 6000 y_1 \quad (2.198)$$

The motion along the coordinate y_1 is determined by the function 2.193

$$y_1 = -.0038 \cos 30t + .0011 \sin 30t - 3.15 \times 10^{-3} \cos 35t + 3.78 \times 10^{-4} \sin 35t \quad (2.199)$$

Hence

$$\begin{aligned} R_B &= 6000 (-.0038 \cos 30t + .0011 \sin 30t - 3.15 \times 10^{-3} \cos 35t + 3.78 \times 10^{-4} \sin 35t) \\ M_B &= 6000 \cdot 1 \cdot (-.0038 \cos 30t + .0011 \sin 30t - 3.15 \times 10^{-3} \cos 35t + 3.78 \times 10^{-4} \sin 35t) \end{aligned} \quad (2.200)$$

Problem 30

The link 1 of a mass m_1 , shown in Fig. 40, can move along the horizontal slide and is supported by two springs 3 each of stiffness k . The ball 2 of mass m_2 and a radius r is hinged to the link 1 at the point A by means of the massless and rigid rod 4. All motion is in the vertical plane. The equation of motion, in terms of the coordinates x and φ (see Fig. 41) have been formulated in page 81 to be

$$\mathbf{m}\ddot{\mathbf{x}} + \mathbf{k}\mathbf{x} = \mathbf{0} \quad (2.201)$$

where

$$\mathbf{m} = \begin{bmatrix} m_1 + m_2 & m_2 R \\ m_2 R & m_2 R^2 + I \end{bmatrix}, \quad \mathbf{k} = \begin{bmatrix} 2k & 0 \\ 0 & m_2 g R \end{bmatrix}, \quad \mathbf{x} = \begin{bmatrix} x \\ \varphi \end{bmatrix}, \quad I = \frac{2}{5} m_2 r^2 \quad (2.202)$$

At the instant $t = 0$, the link 1 was placed to the position shown in Fig. 42 and released with the initial velocity equal to zero.

For the following data:

$$m_1 = 2 \text{ kg}$$

$$m_2 = 1 \text{ kg}$$

$$R = 0.1 \text{ m}$$

$$r = .05 \text{ m}$$

$$k = 1000 \text{ N/m}$$

$$a = 0.01 \text{ m}$$

Produce:

1. the natural frequencies of the system
2. the normalized natural modes
3. the differential equation of motion in terms of the normal coordinates
4. the equation motion of the system along the coordinates x and φ due to the given initial conditions.

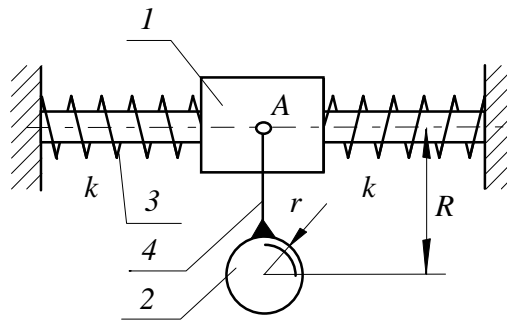

Figure 40

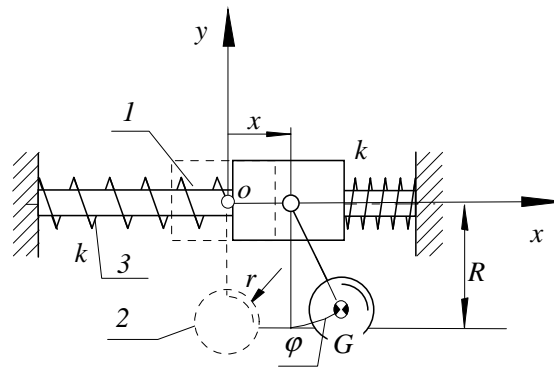

Figure 41

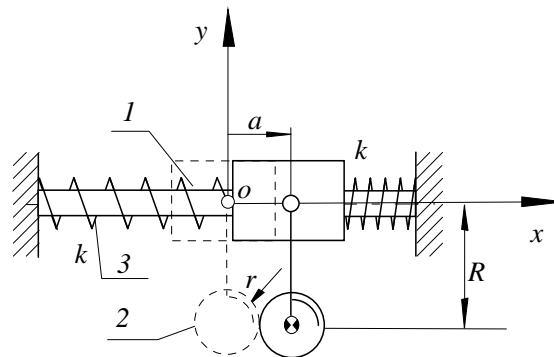

Figure 42

Solution

1. The natural frequencies and the natural modes

According to the given numerical data the moment of inertia of the ball, the inertia matrix and the stiffness matrix are

$$\begin{aligned} I &= \frac{2}{5} \cdot 1 \cdot 0.05^2 = 0.001 \text{ kgm}^2 \\ \mathbf{m} &= \begin{bmatrix} 2 + 1 & 1 \cdot 0.1 \\ 1 \cdot 0.1 & 1 \cdot 0.1^2 + 0.001 \end{bmatrix} = \begin{bmatrix} 3.0 & .1 \\ .1 & .011 \end{bmatrix} \\ \mathbf{k} &= \begin{bmatrix} 1000 & 0 \\ 0 & 1 \cdot 10 \cdot 0.1 \end{bmatrix} = \begin{bmatrix} 1000.0 & 0 \\ 0 & 1.0 \end{bmatrix} \end{aligned} \quad (2.203)$$

According to 2.108 (page 102) one can write the following set of equations

$$(-\omega_n^2 \mathbf{m} + \mathbf{k})\mathbf{X} = \mathbf{0} \quad (2.204)$$

where ω stands for the natural frequency and \mathbf{X} is the corresponding natural mode. Hence for the given numerical data we are getting

$$\begin{bmatrix} -3.0\omega_n^2 + 1000.0 & -.1\omega_n^2 \\ -.1\omega_n^2 & -.011\omega_n^2 + 1.0 \end{bmatrix} \begin{bmatrix} X \\ \Phi \end{bmatrix} = \begin{bmatrix} 0 \\ 0 \end{bmatrix} \quad (2.205)$$

This set of equations has non-zero solution if and only if its determinant is equal to zero. Hence the equation for the natural frequencies is.

$$\left| \begin{bmatrix} -3.0\omega_n^2 + 1000.0 & -.1\omega_n^2 \\ -.1\omega_n^2 & -.011\omega_n^2 + 1.0 \end{bmatrix} \right| = .023\omega_n^4 - 14.0\omega_n^2 + 1000.0 = 0 \quad (2.206)$$

Its roots:

$$[22.936 \quad -22.936 \quad 9.0913 \quad -9.0913]$$

yield the wanted natural frequencies

$$\omega_1 = 9.0913 \quad \omega_2 = 22.936 \text{ [s}^{-1}\text{]} \quad (2.207)$$

For $\omega_n = \omega_1 = 9.0913$ the equations 2.205 become linearly dependent. Therefore, one of the unknown can be chosen arbitrarily (e.g. $X_1 = 1$) and the other may be produced from the first equation of the set 2.205.

$$\begin{aligned} X_1 &= 1 \\ -3.0X_1\omega_1^2 + 1000.0X_1 - .1\omega_1^2\Phi_1 &= 0 \\ \Phi_1 &= \frac{1}{.1 \cdot 9.0913^2} - 3.0 \cdot 9.0913^2 + 1000.0) = 90.99 \end{aligned} \quad (2.208)$$

These two numbers form the first mode of vibrations corresponding to the first natural frequency ω_1 . Similar consideration, carried out for the natural frequency $\omega_2 = 22.936$, yields the second mode.

$$\begin{aligned} X_2 &= 1 \\ \Phi_2 &= \frac{1}{.1 \cdot 22.936^2} (-3.0 \cdot 22.936^2 + 1000.0) = -10.991 \end{aligned} \quad (2.209)$$

Now, one can create the modal matrix

$$\mathbf{X} = [\mathbf{X}_1, \mathbf{X}_2] = \begin{bmatrix} 1 & 1 \\ 90.99 & -10.991 \end{bmatrix} \quad (2.210)$$

In this case the modal matrix has two eigenvectors \mathbf{X}_1 and \mathbf{X}_2 .

$$\mathbf{X}_1 = \begin{bmatrix} 1 \\ 90.99 \end{bmatrix}; \mathbf{X}_2 = \begin{bmatrix} 1 \\ -10.991 \end{bmatrix} \quad (2.211)$$

2. Normalization of the natural modes

According to 2.121 the normalization factor is

$$\mathbf{X}_n^T \mathbf{m} \mathbf{X}_n = \lambda_n^2 \quad (2.212)$$

Hence

$$\begin{aligned} \lambda_1^2 &= [1 \quad 90.99] \begin{bmatrix} 3.0 & .1 \\ .1 & .011 \end{bmatrix} \begin{bmatrix} 1 \\ 90.99 \end{bmatrix} = 112.27 \\ \lambda_1 &= \sqrt{112.27} = 10.596 \end{aligned} \quad (2.213)$$

Division of the eigenvector \mathbf{X}_1 by the factor λ_1 yields the normalized mode $\mathbf{\Xi}_1$.

$$\mathbf{\Xi}_1 = \frac{1}{10.596} \begin{bmatrix} 1 \\ 90.99 \end{bmatrix} = \begin{bmatrix} 9.4375 \times 10^{-2} \\ 8.5872 \end{bmatrix} \quad (2.214)$$

Similar procedure allows the second normalized mode to be obtained

$$\begin{aligned} \lambda_2^2 &= [1 \quad -10.991] \begin{bmatrix} 3.0 & .1 \\ .1 & .011 \end{bmatrix} \begin{bmatrix} 1 \\ -10.991 \end{bmatrix} = 2.1306 \\ \lambda_2 &= \sqrt{2.1306} = 1.4597 \\ \mathbf{\Xi}_2 &= \frac{1}{1.4597} \begin{bmatrix} 1 \\ -10.991 \end{bmatrix} = \begin{bmatrix} .68507 \\ -7.5296 \end{bmatrix} \end{aligned} \quad (2.215)$$

These two vectors forms the normalized modal matrix $\mathbf{\Xi}$.

$$\mathbf{\Xi} = \begin{bmatrix} 9.4375 \times 10^{-2} & .68507 \\ 8.5872 & -7.5296 \end{bmatrix} \quad (2.216)$$

The normalized eigenvectors must be orthogonal with respect to both the inertia matrix and the stiffness matrix. Indeed.

$$\begin{aligned} \mathbf{\Xi}^T \mathbf{m} \mathbf{\Xi} &= \\ &= \begin{bmatrix} 9.4375 \times 10^{-2} & 8.5872 \\ .68507 & -7.5296 \end{bmatrix} \begin{bmatrix} 3.0 & .1 \\ .1 & .011 \end{bmatrix} \begin{bmatrix} 9.4375 \times 10^{-2} & .68507 \\ 8.5872 & -7.5296 \end{bmatrix} \\ &= \begin{bmatrix} 1 & 0 \\ 0 & 1 \end{bmatrix} \end{aligned} \quad (2.217)$$

and

$$\begin{aligned}
 \Xi^T \mathbf{k} \Xi &= \\
 &= \begin{bmatrix} 9.4375 \times 10^{-2} & 8.5872 \\ .68507 & -7.5296 \end{bmatrix} \begin{bmatrix} 1000 & 0 \\ 0 & 1 \cdot 10 \cdot 0.1 \end{bmatrix} \begin{bmatrix} 9.4375 \times 10^{-2} & .68507 \\ 8.5872 & -7.5296 \end{bmatrix} \\
 &= \begin{bmatrix} 82.647 & 0 \\ 0 & 526.02 \end{bmatrix} = \begin{bmatrix} (9.091)^2 & 0 \\ 0 & (22.935)^2 \end{bmatrix} = \begin{bmatrix} \omega_1^2 & 0 \\ 0 & \omega_2^2 \end{bmatrix} \quad (2.218)
 \end{aligned}$$

3. The differential equation of motion in terms of the normal coordinates

Introducing the substitution 2.131

$$\mathbf{x} = \Xi \boldsymbol{\eta} \quad (2.219)$$

that in the case considered has the following form

$$\begin{bmatrix} X \\ \Phi \end{bmatrix} = \Xi \boldsymbol{\eta} = \Xi \begin{bmatrix} \eta_1 \\ \eta_2 \end{bmatrix} \quad (2.220)$$

into 2.201 and premultiplying them from the left hand side by Ξ^T we are getting the differential equations of motion in terms of the normal coordinates $\boldsymbol{\eta}$.

$$(\Xi^T \mathbf{m} \Xi) \ddot{\boldsymbol{\eta}} + (\Xi^T \mathbf{k} \Xi) \boldsymbol{\eta} = \mathbf{0} \quad (2.221)$$

Taking advantage of the orthogonality conditions, the equations of motion are of the following form

$$\begin{bmatrix} 1 & 0 \\ 0 & 1 \end{bmatrix} \ddot{\boldsymbol{\eta}} + \begin{bmatrix} (9.091)^2 & 0 \\ 0 & (22.935)^2 \end{bmatrix} \boldsymbol{\eta} = \mathbf{0} \quad (2.222)$$

or

$$\begin{aligned}
 \ddot{\eta}_1 + (9.091)^2 \eta_1 &= 0 \\
 \ddot{\eta}_2 + (22.935)^2 \eta_2 &= 0
 \end{aligned} \quad (2.223)$$

The general solution of the above set of the differential equations, according to 1.36 is

$$\begin{aligned}
 \eta_1 &= \frac{v_{01}}{\omega_1} \sin \omega_1 t + \eta_{01} \cos \omega_1 t \\
 \eta_2 &= \frac{v_{02}}{\omega_2} \sin \omega_2 t + \eta_{02} \cos \omega_2 t
 \end{aligned} \quad (2.224)$$

Where η_{01} and η_{02} stand for the initial position whereas v_{01} and v_{02} stand for the initial velocity of the system along the normal coordinates. These initial conditions must be formulated along the normal coordinates. It can be obtained by transforming the initial conditions from the physical coordinates to the normal coordinates.

$$\begin{aligned}
 \begin{bmatrix} \eta_{01} \\ \eta_{02} \end{bmatrix} &= \Xi^{-1} \begin{bmatrix} X_o \\ \Phi_o \end{bmatrix} = \Xi^{-1} \begin{bmatrix} a \\ 0 \end{bmatrix} = \begin{bmatrix} 1.142 & .1039 \\ 1.3024 & -1.4313 \times 10^{-2} \end{bmatrix} \begin{bmatrix} 0.01 \\ 0 \end{bmatrix} \\
 &= \begin{bmatrix} .01142 \\ 1.3024 \times 10^{-2} \end{bmatrix} \quad (2.225)
 \end{aligned}$$

$$\begin{bmatrix} v_{01} \\ v_{02} \end{bmatrix} = \begin{bmatrix} 0 \\ 0 \end{bmatrix} \quad (2.226)$$

Introduction of the above initial conditions into the equations 2.224 results in motion of the system along the normal coordinates

$$\begin{aligned} \eta_1 &= \eta_{01} \cos \omega_1 t = .01142 \cos 9.091t \\ \eta_2 &= \eta_{02} \cos \omega_2 t = 1.3024 \times 10^{-2} \cos 22.935t \end{aligned} \quad (2.227)$$

4. The equations of motion of the system along the coordinates x and φ

To produce equation of motion along the physical coordinates, one has to transform the motion along the normal coordinates back to the physical ones. Hence, using the relationship 2.219, we are getting

$$\begin{aligned} \begin{bmatrix} X \\ \Phi \end{bmatrix} &= \Xi \eta = \begin{bmatrix} 9.4375 \times 10^{-2} & .68507 \\ 8.5872 & -7.5296 \end{bmatrix} \begin{bmatrix} .01142 \cos 9.091t \\ 1.3024 \times 10^{-2} \cos 22.935t \end{bmatrix} = \\ &= \begin{bmatrix} 1.0778 \times 10^{-3} \cos 9.091t + 8.9224 \times 10^{-3} \cos 22.935t \\ 9.8066 \times 10^{-2} \cos 9.091t - 9.8066 \times 10^{-2} \cos 22.935t \end{bmatrix} \end{aligned} \quad (2.228)$$

This motion is presented in Fig. 43 and 44

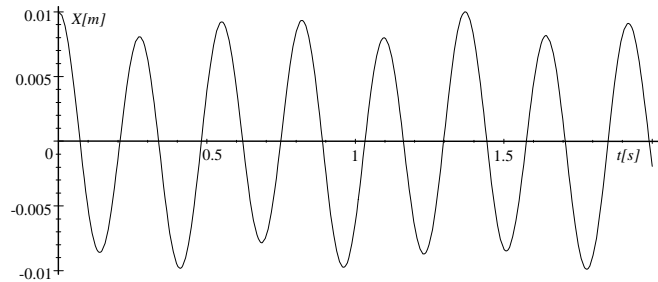

Figure 43

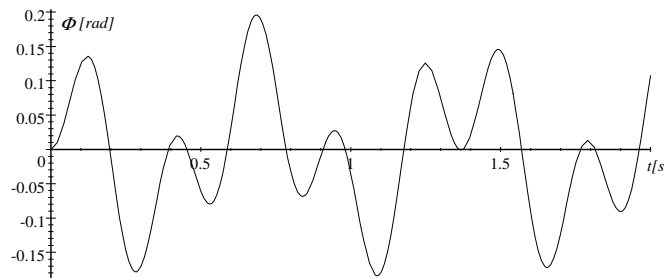

Figure 44

Problem 31

Figure 45

The rigid beam 1 of mass M , length L and the moment of inertia about its point of rotation I_A , is supported by means of the spring of stiffness k and the damper of the damping coefficient c as shown in Fig. 45. The beam 2 is massless and the Young's modulus E and the second moment of area J determine its dynamic properties. Its end D is fixed and the particle 3 of mass m is attached to the end C .

Derive an expression for the fixing moment and the fixing force at the point D due to the exciting force F that is applied to the system at the point B .

Problem 32

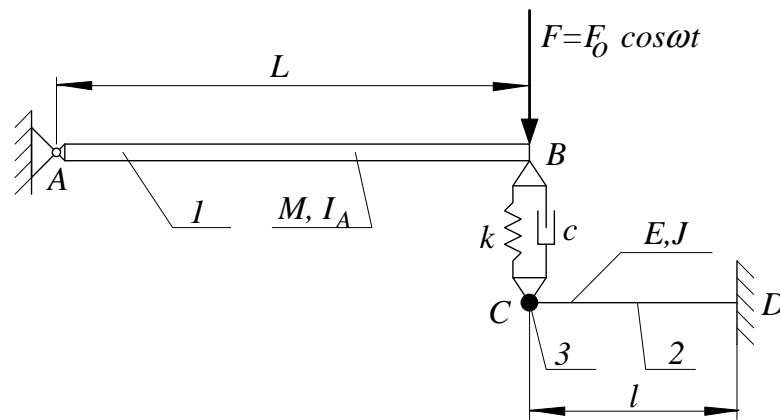
Figure 46

The two rods, 1 and 2, are suspended in the vertical plane as shown in Fig. 46. Their mass and their moment of inertia about their points of rotation are respectively m_1, I_{O1} , and m_2, I_{O2} . These rods are connected to each other by means of springs of the stiffness k, k_1, k_2 and as well as the damper of the damping coefficient c . The centres of gravity of these rods are denoted by G_1 and G_2 respectively. Vibrations of the system are excited by the two harmonic forces of amplitudes F_1, F_2 and frequencies ω_1 and ω_2 .

Produce

1. the differential equation of the small vibrations of the system in the matrix form

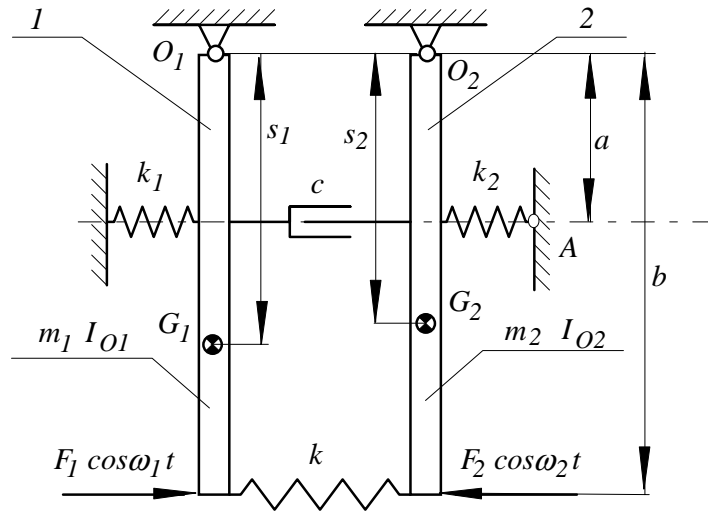
Answer:

$$\mathbf{M}\ddot{\mathbf{x}} + \mathbf{C}\dot{\mathbf{x}} + \mathbf{K}\mathbf{x} = \mathbf{F}$$

$$\mathbf{M} = \begin{bmatrix} I_{O1} & 0 \\ 0 & I_{O2} \end{bmatrix}; \quad \mathbf{C} = \begin{bmatrix} ca^2 & -ca^2 \\ -ca^2 & ca^2 \end{bmatrix}; \quad \mathbf{K} = \begin{bmatrix} k_1 a^2 + kb^2 + m_1 g s_1 & -kb^2 \\ -kb^2 & k_2 a^2 + kb^2 + m_2 g s_2 \end{bmatrix};$$

$$\mathbf{x} = \begin{bmatrix} \varphi_1 \\ \varphi_2 \end{bmatrix}; \quad \mathbf{F} = \begin{bmatrix} F_1 b \\ 0 \end{bmatrix} \cos \omega_1 t + \begin{bmatrix} 0 \\ -F_2 b \end{bmatrix} \cos \omega_2 t$$

2. the expression for the forced vibrations of the rods

Answer:

$$\mathbf{X} = \mathbf{X}_1 + \mathbf{X}_2$$

$$\mathbf{X}_1 - \text{particular solution of equation } \mathbf{M}\ddot{\mathbf{x}} + \mathbf{C}\dot{\mathbf{x}} + \mathbf{K}\mathbf{x} = \begin{bmatrix} F_1 b \\ 0 \end{bmatrix} \cos \omega_1 t$$

$$\mathbf{X}_2 - \text{particular solution of equation } \mathbf{M}\ddot{\mathbf{x}} + \mathbf{C}\dot{\mathbf{x}} + \mathbf{K}\mathbf{x} = \begin{bmatrix} 0 \\ -F_2 b \end{bmatrix} \cos \omega_2 t$$

3. the expression for the dynamic reaction at the point A.

Answer:

$$R_A = \Phi_2 a k_2; \quad \Phi_2 - \text{the lower element of the matrix } \mathbf{X}$$

Problem 33

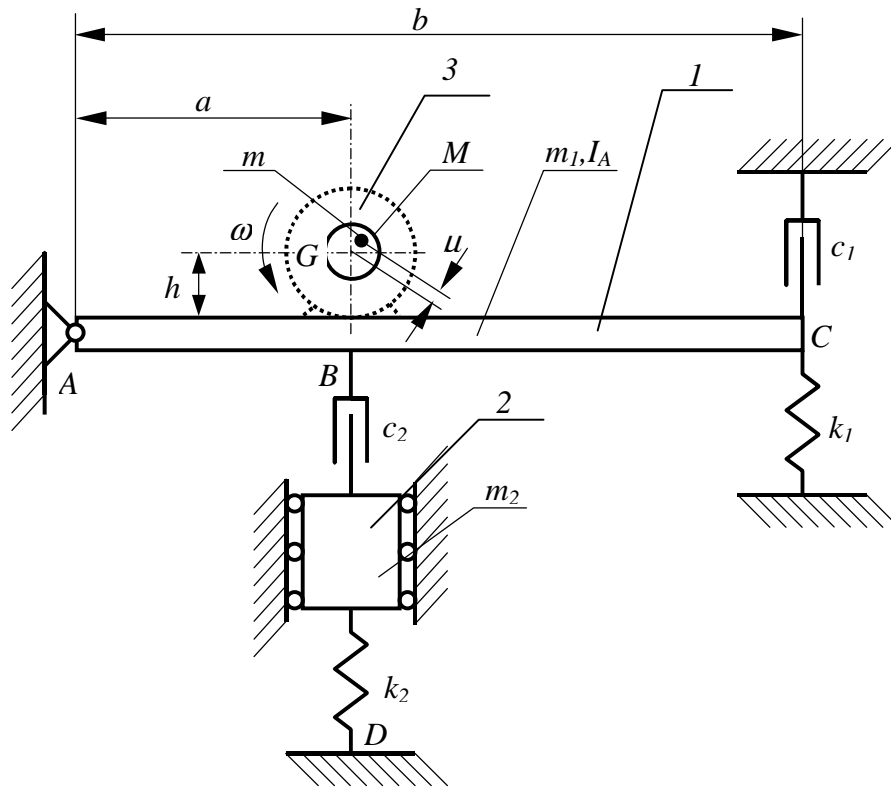

Figure 47

The rigid beam 1 (see Fig. 47) is hinged at the point A and is supported at the point C by means of the spring of stiffness k_1 and the damper of the damping coefficient c_1 . Its mass and its moment of inertia about A are m_1 and I_A respectively. The motor 3 is mounted on this beam. It can be approximated by a particle of the mass M that is concentrated at the point G that is located by the dimensions h and a . The rotor of this motor rotates with the constant velocity ω . Its mass is equal to m and its unbalance is μ . To attenuate the vibrations of the beam the block 2 of mass m_2 was attached. The damping coefficient of the damper between the beam and the block is denoted by c_2 and the stiffness of the supporting spring is denoted by k_2 .

Produce

1. the differential equation of motion of the system and present it in the standard matrix form.

Answer:

$$\mathbf{M}\ddot{\mathbf{x}} + \mathbf{C}\dot{\mathbf{x}} + \mathbf{K}\mathbf{x} = \mathbf{F}$$

$$\mathbf{M} = \begin{bmatrix} I_A + M(h^2 + a^2) & 0 \\ 0 & m_2 \end{bmatrix}; \quad \mathbf{C} = \begin{bmatrix} c_1 b^2 + c_2 a^2 & -c_2 a \\ -c_2 a & c_2 \end{bmatrix}; \quad \mathbf{K} = \begin{bmatrix} k_1 b & 0 \\ 0 & k_2 \end{bmatrix};$$

$$\mathbf{x} = \begin{bmatrix} \alpha \\ x \end{bmatrix}; \quad \mathbf{F} = \begin{bmatrix} m\mu\omega^2\sqrt{h^2 + a^2} \\ 0 \end{bmatrix} \cos \omega t$$

α - the angular displacement of the beam1; x - the linear displacement of the block
2

2. Produce the expression for the interaction forces at the point A and D .

Problem 34

Figure 48

Three uniform platforms each of the length l , the mass m and the moment of inertia about axis through its centre of gravity I_G are hinged together to form a bridge that is shown in Fig. 48. This bridge is supported by means of two springs each of the stiffness k . This system has two degree of freedom and the two generalized coordinates are denoted by α and β . There is an excitation force F applied at the hinge C . This force can be adopted in the following form

$$F = F_o \cos \omega t$$

Produce:

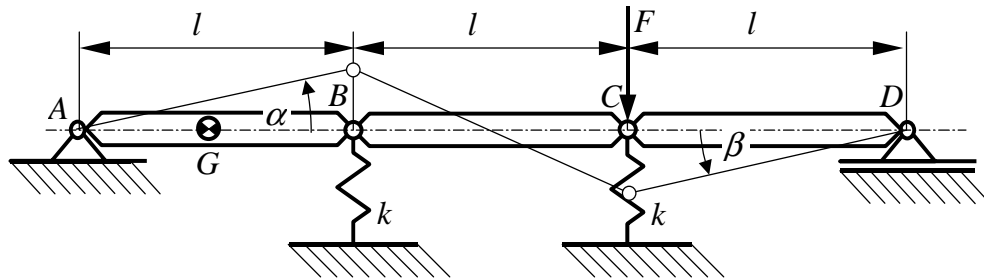
1. the differential equations of motion of the system and present them in the standard form

Answer:

$$\mathbf{M}\ddot{\mathbf{x}} + \mathbf{K}\mathbf{x} = \mathbf{F}$$

$$\mathbf{M} = \begin{bmatrix} \frac{2}{3} & -\frac{1}{6} \\ -\frac{1}{6} & \frac{2}{3} \end{bmatrix} ml^2; \quad \mathbf{K} = \begin{bmatrix} 1 & 0 \\ 0 & 1 \end{bmatrix} kl^2; \quad \mathbf{x} = \begin{bmatrix} \alpha \\ \beta \end{bmatrix}; \quad \mathbf{F} = \begin{bmatrix} 0 \\ F_o l \end{bmatrix} \cos \omega t$$

2. the equation for the natural frequencies of the system

Answer:

$$|\mathbf{K} - \mathbf{1}\omega_n| = 0$$

3. the expression for the amplitude of the forced vibrations of the system

Answer:

$$\mathbf{X} = [-\omega^2 \mathbf{M} + \mathbf{K}]^{-1} \begin{bmatrix} 0 \\ F_o l \end{bmatrix} \cos \omega t = \begin{bmatrix} A \\ B \end{bmatrix}$$

4. the expression for the interaction force between the spring attached to the hinge B and the ground

Answer:

$$R = Akl \cos \omega t$$

Problem 35

Figure 49

Figure. 49 shows the physical model of a trolley. It was modelled as a system with two degree of freedom. Its position is determined by two generalized coordinates x and φ . The moment of inertia of the trolley about the point A is denoted by I_A and its mass by m_1 . The dynamic properties of the shock-absorber are approximated by the spring of stiffness k and damper of the damping coefficient c . Mass of the wheels 2 are denoted by m and the stiffness of its tire is k_1 . Motion of the trolley is excited by roughness of the road. It causes motion of the point B according to the following function.

$$y = A \sin \omega t$$

Produce:

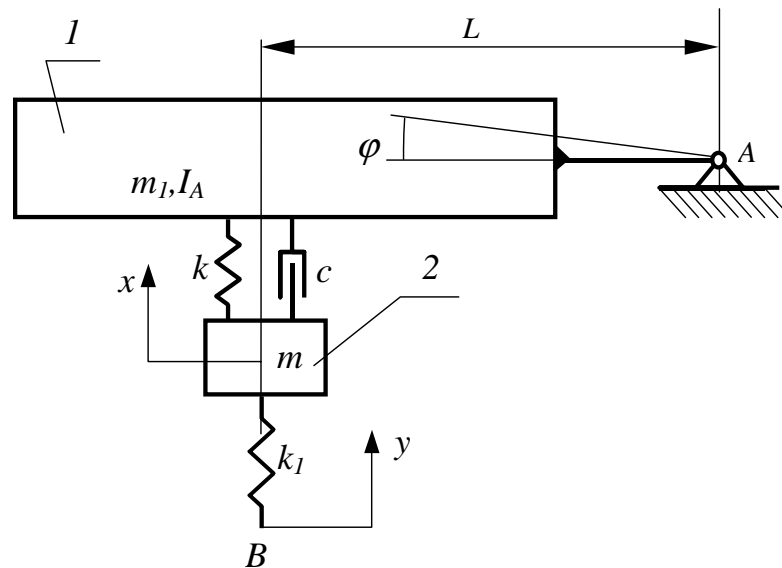
1. the differential equation of motion of the system
2. the equation for the natural frequencies of the system
3. the expression for the amplitudes of the steady state vibration of the system
4. the expression for the amplitude of the interaction force between the tire and surface of the road.

Problem 36

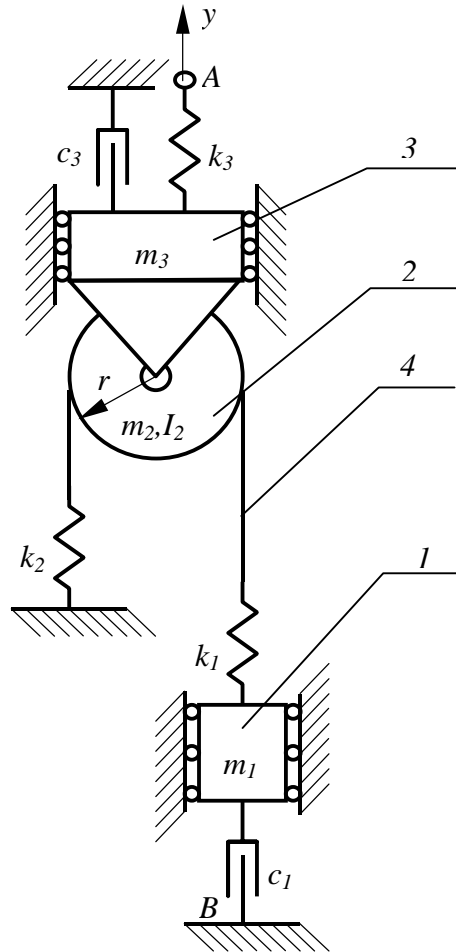

Figure 50

In Fig. 50 the physical model of a winch is shown. The blocks 1 and 3 are rigid and their masses are respectively m_1 and m_3 respectively. The rigid pulley 2 has radius r , mass m_2 and the moment of inertia about its axis of rotation I_2 . The elastic properties of the rope 4 are modeled by two springs of stiffness k_1 and k_2 . The point A moves with respect to the axis y according to the following equation.

$$y = a \cos \omega t$$

Produce:

1. the differential equation of motion of the system and present it in the following matrix form.

$$\mathbf{M}\ddot{\mathbf{x}} + \mathbf{C}\dot{\mathbf{x}} + \mathbf{K}\mathbf{x} = \mathbf{F}$$

Answer:

$$\mathbf{M} = \begin{bmatrix} m_1 & 0 & 0 \\ 0 & m_2 + m_3 & 0 \\ 0 & 0 & I_2 \end{bmatrix}; \quad \mathbf{C} = \begin{bmatrix} c_1 & 0 & 0 \\ 0 & c_3 & 0 \\ 0 & 0 & 0 \end{bmatrix}$$

$$\mathbf{K} = \begin{bmatrix} k_1 & -k_1 & -k_1 r \\ -k_1 & k_1 + k_2 + k_3 & k_1 r - k_2 r \\ -k_1 r & k_1 r - k_2 r & (k_1 + k_2) r^2 \end{bmatrix} \quad \mathbf{F} = \begin{bmatrix} 0 \\ ak_3 \\ 0 \end{bmatrix} \cos \omega t; \quad \mathbf{x} = \begin{bmatrix} x_1 \\ x_2 \\ \varphi \end{bmatrix}$$

x_1 - the linear displacement of the block 1

x_2 - the linear displacement of the pulley 2 and the block 3

φ - the angular displacement of the pulley 2

2. the expression for the amplitudes of the forced vibrations of the system

Answer:

The particular solution \mathbf{x}_p of the equation $\mathbf{M}\ddot{\mathbf{x}} + \mathbf{C}\dot{\mathbf{x}} + \mathbf{K}\mathbf{x} = \mathbf{F}$

The first element x_{p1} of the matrix \mathbf{x}_p represents displacement of the block 1

3. the expression for the interaction force at point B .

Answer

$$R_B = c_1 \dot{x}_{p1}$$

Problem 37

Figure 51

Figure 51 shows the physical model of a compressor. The disks of moment of inertia I_1 , I_2 , and I_3 are connected to each other by means of the massless shafts that the torsional stiffness are k_1 , k_2 and k_3 respectively. The shaft k_1 is connected to the shaft k_2 by means of the gear of ratio $i = D_1/D_2$. There is a torque T_3 applied to the disk I_3 . It can be approximated by the following function

$$T_3 = T \cos \omega t$$

Produce:

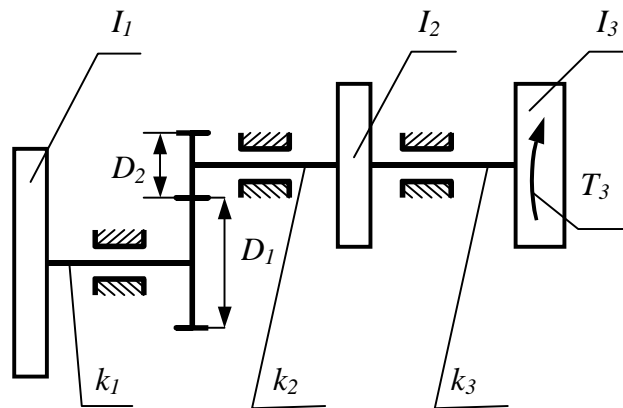
1. the differential equation of motion of the system and present it in the following matrix form.

$$\mathbf{M}\ddot{\mathbf{x}} + \mathbf{C}\dot{\mathbf{x}} + \mathbf{K}\mathbf{x} = \mathbf{F}$$

2. the expression for the amplitudes of the forced vibrations of the system
3. the expression for the torque transmitted through the shaft k_1 .

Solution

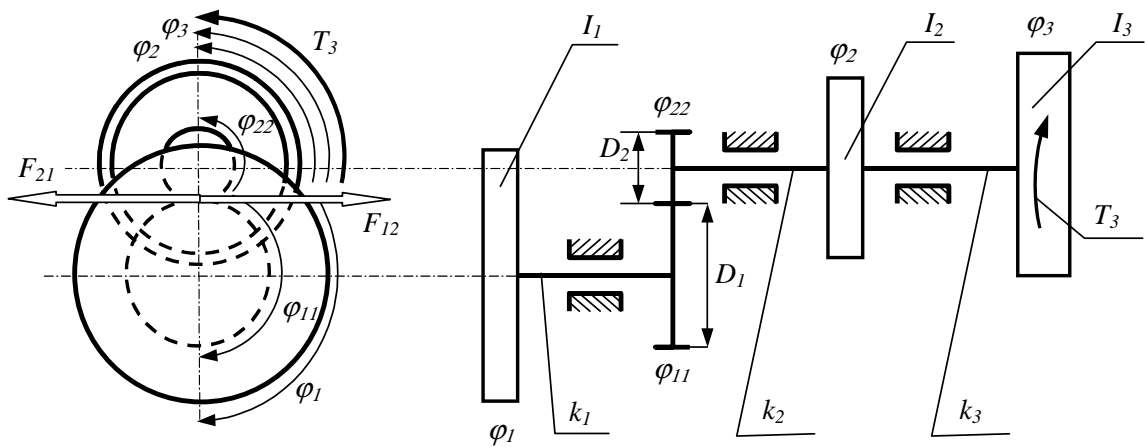

Figure 52

To produce the equations of motion of the system one may split it into five rigid bodies (Newton approach) and write the following set of equations

$$\begin{aligned}
 I_1 \ddot{\varphi}_1 &= -k_1 \varphi_1 + k_1 \varphi_{11} \\
 0 &= -k_1 \varphi_{11} + k_1 \varphi_1 + F_{12} \frac{D_1}{2} \\
 0 &= -k_2 \varphi_{22} + k_2 \varphi_2 - F_{21} \frac{D_2}{2} \\
 I_2 \ddot{\varphi}_2 &= -(k_2 + k_3) \varphi_2 + k_2 \varphi_{22} + k_3 \varphi_3 \\
 I_3 \ddot{\varphi}_3 &= -k_3 \varphi_3 + k_3 \varphi_2 + T_3
 \end{aligned} \tag{2.229}$$

where F_{12} F_{21} stand for the interaction forces between the rear D_1 and D_2 .

In the above equations not all variables are independent.

$$\varphi_{22} = i \varphi_{11} \tag{2.230}$$

Hence the equations can be rewritten as follows

$$\begin{aligned}
 I_1 \ddot{\varphi}_1 &= -k_1 \varphi_1 + k_1 \varphi_{11} \\
 0 &= -k_1 \varphi_{11} + k_1 \varphi_1 + F_{12} \frac{D_1}{2} \\
 0 &= -k_2 i \varphi_{11} + k_2 \varphi_2 - F_{21} \frac{D_2}{2} \\
 I_2 \ddot{\varphi}_2 &= -(k_2 + k_3) \varphi_2 + k_2 i \varphi_{11} + k_3 \varphi_3 \\
 I_3 \ddot{\varphi}_3 &= -k_3 \varphi_3 + k_3 \varphi_2 + T_3
 \end{aligned} \tag{2.231}$$

According to the third Newton's law we have

$$F_{12} = F_{21} \tag{2.232}$$

Hence the second and third equation yields

$$F_{12} = \frac{2}{D_1} (k_1\varphi_{11} - k_1\varphi_1) = \frac{2}{D_2} (-k_2i\varphi_{11} + k_2\varphi_2) = F_{21} \quad (2.233)$$

$$k_1\varphi_{11} - k_1\varphi_1 = \frac{D_1}{D_2} (-k_2i\varphi_{11} + k_2\varphi_2)$$

The equation 2.233 allows the angular displacement φ_{11} to be expressed in terms of the displacements φ_1 and φ_2 .

$$\varphi_{11} = \frac{k_1}{k_1 + k_2i^2}\varphi_1 + \frac{ik_2}{k_1 + k_2i^2}\varphi_2 \quad (2.234)$$

Introduction of this relationship into the first, second and fifth equation of the set 2.231 one can get

$$\begin{aligned} I_1\ddot{\varphi}_1 &= -k_1\varphi_1 + \frac{k_1^2}{k_1 + k_2i^2}\varphi_1 + \frac{ik_1k_2}{k_1 + k_2i^2}\varphi_2 \\ I_2\ddot{\varphi}_2 &= -(k_2 + k_3)\varphi_2 + \frac{k_1k_2i}{k_1 + k_2i^2}\varphi_1 + \frac{i^2k_2^2}{k_1 + k_2i^2}\varphi_2 + k_3\varphi_3 \\ I_3\ddot{\varphi}_3 &= -k_3\varphi_3 + k_3\varphi_2 + T_3 \end{aligned} \quad (2.235)$$

or

$$\begin{aligned} \left(\frac{1}{i^2}I_1\right)(i\ddot{\varphi}_1) &= -k_e(i\varphi_1) + k_e\varphi_2 \\ I_2\ddot{\varphi}_2 &= -k_e\varphi_2 - k_3\varphi_2 + k_e(i\varphi_1) + k_3\varphi_3 \\ I_3\ddot{\varphi}_3 &= -k_3\varphi_3 + k_3\varphi_2 + T_3 \end{aligned} \quad (2.236)$$

where

$$k_e = \frac{k_1k_2}{k_1 + i^2k_2} \quad (2.237)$$

The above set of equations can be now presented in the matrix form

$$\mathbf{M}\ddot{\mathbf{x}} + \mathbf{C}\dot{\mathbf{x}} + \mathbf{K}\mathbf{x} = \mathbf{F} \quad (2.238)$$

where

$$\begin{aligned} \mathbf{M} &= \begin{bmatrix} \frac{1}{i^2}I_1 & & \\ & I_2 & \\ & & I_3 \end{bmatrix}; \quad \mathbf{C} = \mathbf{0}; \quad \mathbf{K} = \begin{bmatrix} k_e & -k_e & 0 \\ -k_e & k_e + k_3 & -k_3 \\ 0 & -k_3 & k_3 \end{bmatrix}; \quad \mathbf{x} = \begin{bmatrix} i\varphi_1 \\ \varphi_2 \\ \varphi_3 \end{bmatrix} \\ \mathbf{F} &= \begin{bmatrix} 0 \\ 0 \\ T \cos \omega t \end{bmatrix} \end{aligned} \quad (2.239)$$

The same results one can get by means of the Lagrange's equations

The kinetic energy function and the potential energy function of the system considered are

$$T = \frac{1}{2}I_1\dot{\varphi}_1^2 + \frac{1}{2}I_2\dot{\varphi}_2^2 + \frac{1}{2}I_3\dot{\varphi}_3^2$$

$$\begin{aligned} V &= \frac{1}{2}k_1(\varphi_{11} - \varphi_1)^2 + \frac{1}{2}k_2(\varphi_2 - \varphi_{22})^2 + \frac{1}{2}k_3(\varphi_3 - \varphi_2)^2 = \\ &= \frac{1}{2}k_1(\varphi_{11} - \varphi_1)^2 + \frac{1}{2}k_2(\varphi_2 - i\varphi_{11})^2 + \frac{1}{2}k_3(\varphi_3 - \varphi_2)^2 \end{aligned}$$

Hence

$$\begin{aligned} \frac{d}{dt} \frac{\partial T}{\partial \dot{\varphi}_1} &= I_1\ddot{\varphi}_1 \\ \frac{d}{dt} \frac{\partial T}{\partial \dot{\varphi}_2} &= I_2\ddot{\varphi}_2 \\ \frac{d}{dt} \frac{\partial T}{\partial \dot{\varphi}_3} &= I_3\ddot{\varphi}_3 \\ \frac{\partial T}{\partial \varphi_1} &= 0; \quad \frac{\partial T}{\partial \varphi_2} = 0; \quad \frac{\partial T}{\partial \varphi_3} = 0 \end{aligned}$$

$$\begin{aligned} \frac{\partial V}{\partial \varphi_1} &= \frac{1}{2}k_1 2(\varphi_{11} - \varphi_1) \left(\frac{\partial \varphi_{11}}{\partial \varphi_1} - 1 \right) + \frac{1}{2}k_2 2(\varphi_2 - i\varphi_{11}) \left(-i \frac{\partial \varphi_{11}}{\partial \varphi_1} \right) = \\ &= i^2 k_e \varphi_1 - i k_e \varphi_2 \end{aligned}$$

$$\begin{aligned} \frac{\partial V}{\partial \varphi_2} &= \frac{1}{2}k_1 2(\varphi_{11} - \varphi_1) \left(\frac{\partial \varphi_{11}}{\partial \varphi_2} \right) + \frac{1}{2}k_2 2(\varphi_2 - i\varphi_{11}) \left(1 - i \frac{\partial \varphi_{11}}{\partial \varphi_2} \right) + \frac{1}{2}k_3 2(\varphi_3 - \varphi_2) (-1) = \\ &= -k_e i \varphi_1 + (k_e + k_3) \varphi_2 - k_e \varphi_3 \end{aligned}$$

$$\begin{aligned} \frac{\partial V}{\partial \varphi_3} &= \frac{1}{2}k_3 2(\varphi_3 - \varphi_2) (1) = \\ &= -k_3 \varphi_2 + k_3 \varphi_3 \end{aligned}$$

The virtual work produced by the impressed forces acting on the system is

$$\delta W = (0) \varphi_1 + (0) \varphi_2 + (T_3) \varphi_3$$

Introduction of the above expressions into the following Lagrange's equations

$$\begin{aligned} \frac{d}{dt} \frac{\partial T}{\partial \dot{\varphi}_1} - \frac{\partial T}{\partial \varphi_1} + \frac{\partial V}{\partial \varphi_1} &= Q_1 \\ \frac{d}{dt} \frac{\partial T}{\partial \dot{\varphi}_2} - \frac{\partial T}{\partial \varphi_2} + \frac{\partial V}{\partial \varphi_2} &= Q_2 \\ \frac{d}{dt} \frac{\partial T}{\partial \dot{\varphi}_3} - \frac{\partial T}{\partial \varphi_3} + \frac{\partial V}{\partial \varphi_3} &= Q_3 \end{aligned} \tag{2.240}$$

yields the wanted equations of motion of the system considered

$$\begin{aligned} I_1 \ddot{\varphi}_1 + k_e \varphi_1 - i k_e \varphi_2 &= 0 \\ I_2 \ddot{\varphi}_2 + -k_e i \varphi_1 + (k_e + k_3) \varphi_2 - k_e \varphi_3 &= 0 \\ I_3 \ddot{\varphi}_3 + -k_3 \varphi_2 + k_3 \varphi_3 &= T_3 \end{aligned}$$

or

$$\begin{aligned} \left(\frac{I_1}{i^2} \right) (\ddot{\varphi}_1 i) + k_e (\varphi_1 i) - k_e \varphi_2 &= 0 \\ I_2 \ddot{\varphi}_2 - k_e (\varphi_1 i) + (k_e + k_3) \varphi_2 - k_e \varphi_3 &= 0 \\ I_3 \ddot{\varphi}_3 + -k_3 \varphi_2 + k_3 \varphi_3 &= T_3 \end{aligned} \quad (2.241)$$

They are identical with the equation 2.239.

It is easy to see that precisely the same equations possesses the system presented in Fig. 53

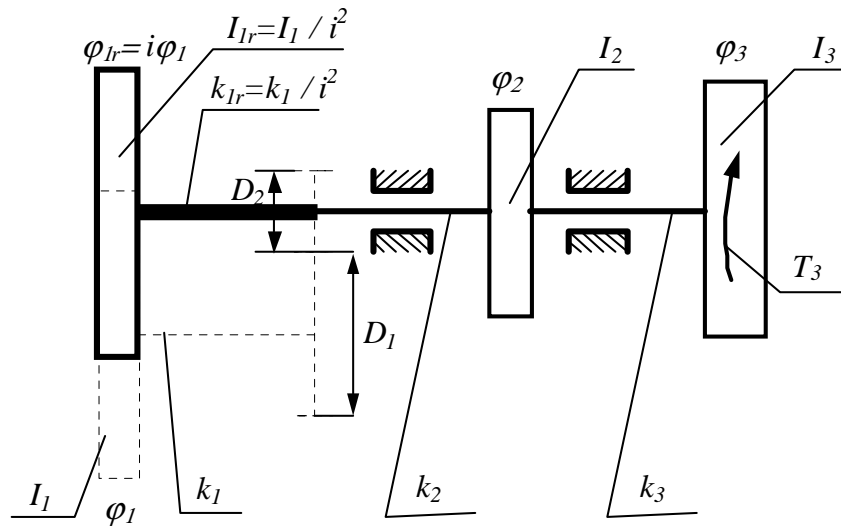

Figure 53

In this figure

$$\varphi_{1r} = i\varphi_1; \quad I_{1r} = \frac{I_1}{i^2}; \quad k_{1r} = \frac{k_1}{i^2} \quad (2.242)$$

stands for so called reduced displacement, reduced moment of inertia and reduced stiffness. The equivalent stiffness of the shaft assembled of the shaft k_2 and k_{1r} can be produced from the following equation

$$\frac{1}{k_e} = \frac{1}{k_{1r}} + \frac{1}{k_2} = \frac{1}{\frac{k_1}{i^2}} + \frac{1}{k_2} \quad (2.243)$$

It is

$$k_e = \frac{k_1 k_2}{k_1 + i^2 k_2} \quad (2.244)$$

Hence, the equations of motion of the system presented in Fig. 53 are as follows

$$\begin{aligned} \left(\frac{I_1}{i^2}\right) (\ddot{\varphi}_1 i) + k_e (\varphi_1 i) - k_e \varphi_2 &= 0 \\ I_2 \ddot{\varphi}_2 - k_e (\varphi_1 i) + (k_e + k_3) \varphi_2 - k_e \varphi_3 &= 0 \\ I_3 \ddot{\varphi}_3 + -k_3 \varphi_2 + k_3 \varphi_3 &= T_3 \end{aligned} \quad (2.245)$$

Problem 38

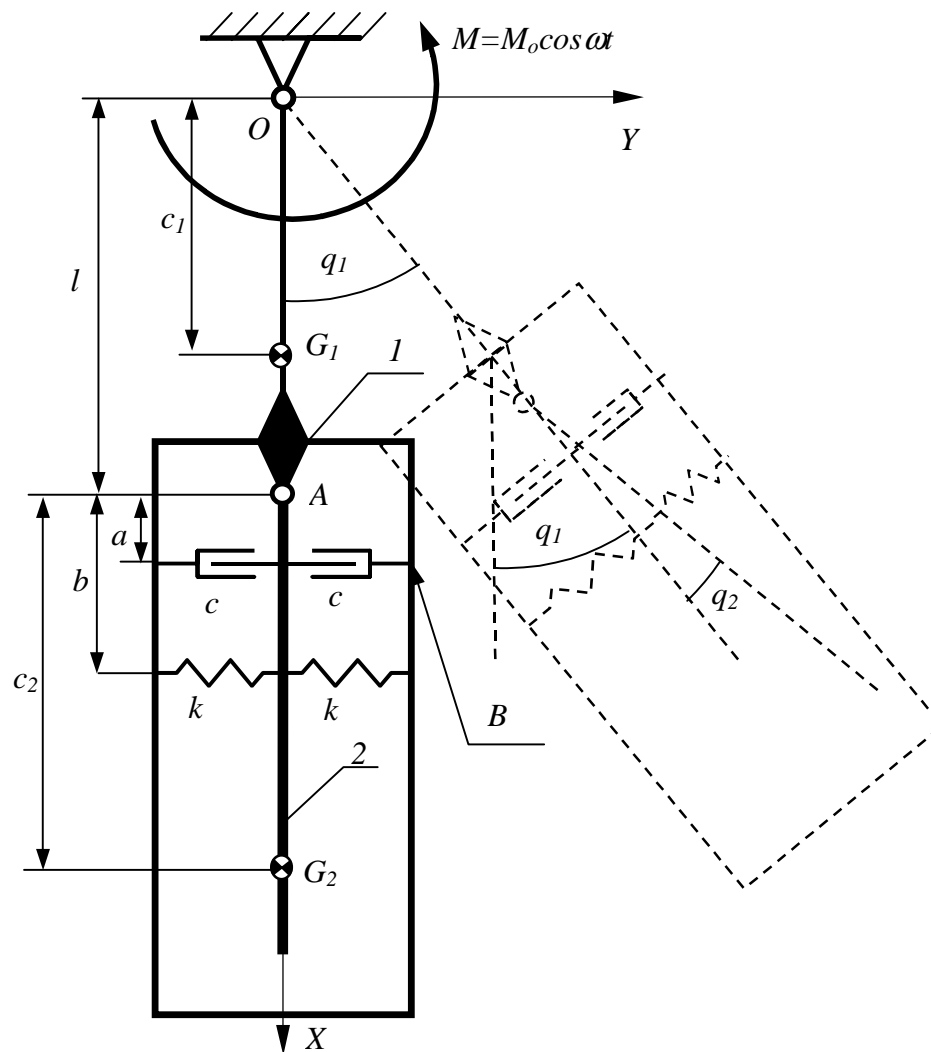

Figure 54

Two rigid bodies 1 and 2 were hinged together at the point A to form the double pendulum whose physical model is shown in Fig.???. These bodies possess masses m_1 and m_2 and the moments of inertia about the axis through their centers of gravity (G_1, G_2) are I_1 and I_2 respectively. The system has two degrees of freedom and the generalized coordinates are denoted by q_1 and q_2 . Vibrations of the pendulum about the horizontal axis Z are excited by the harmonic moment M applied to the body 1.

Produce:

1. the differential equation of small oscillations of the pendulum and present it in the following matrix form

$$M\ddot{x} + C\dot{x} + Kx = F$$

Take advantage of Lagrange's equations.

Answer:

$$\mathbf{x} = \begin{bmatrix} q_1 \\ q_2 \end{bmatrix}; \quad \mathbf{M} = \begin{bmatrix} I_{G1} + m_1 c_1^2 + I_{G2} + m_2(l + c_2)^2 & I_{G2} + m_2 c_2(l + c_2) \\ I_{G2} + m_2 c_2(l + c_2) & I_{G2} m_2 c_2^2 \end{bmatrix};$$

$$\mathbf{K} = \begin{bmatrix} m_1 g c_1 + m_2 g(l + c_2) & m_2 g c_2 \\ m_2 g c_2 & m_2 g c_2 + 2k b^2 \end{bmatrix}; \quad \mathbf{C} = \begin{bmatrix} 0 & 0 \\ 0 & 2c a^2 \end{bmatrix}; \quad \mathbf{F} = \begin{bmatrix} M_o \\ 0 \end{bmatrix}$$

2. the expression for the amplitudes of the forced vibrations of the pendulum
3. the expression for the interaction force between the damper and the body 1 at the point B .

Problem 39

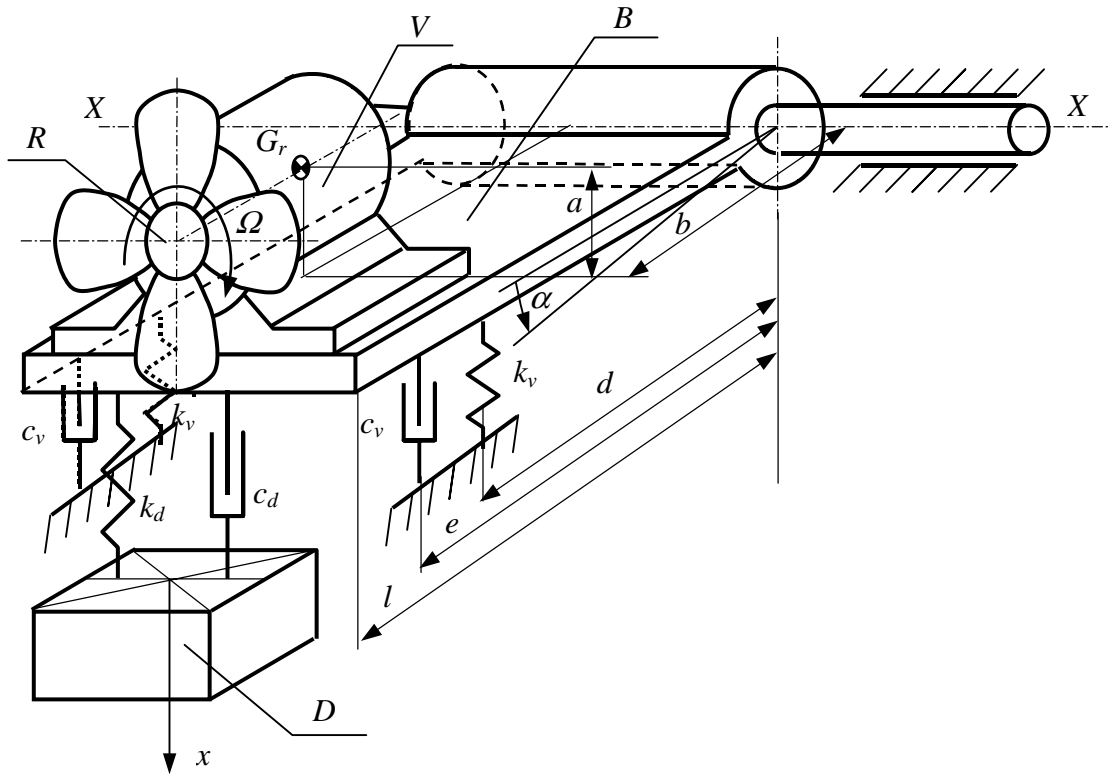

Figure 55

The assembly of the ventilator V and its base B (see Fig. 55) can be considered as a rigid body. This assembly is free to rotate about the horizontal axis $X-X$ and is kept in the horizontal position by means of two springs each of stiffness k_v and two dampers each of the damping coefficient c_v . Its moment of inertia about the axis $X-X$ is I_X . The angular displacement α defines the instantaneous position of this assembly.

The rotor R of the ventilator V possesses a mass m_R and rotates with a constant angular velocity Ω . Its centre of gravity G_r is located by the distances a and b . This rotor is unbalanced and its centre of gravity is off from its axis of rotation by μ .

This assembly is furnished with the dynamic absorber of vibrations. It is made of the block D of mass m_d , the spring of stiffness k_d and the damper of the damping coefficient c_d . The block D can translate along the inertial axis x only.

Produce:

1. The differential equation of small oscillations of the system shown in Fig.1 and present it in the following matrix form

$$\mathbf{M}\ddot{\mathbf{x}} + \mathbf{C}\dot{\mathbf{x}} + \mathbf{K}\mathbf{x} = \mathbf{F}$$

$$\mathbf{M} = \begin{matrix} \text{Answer.} \\ \begin{bmatrix} I_x & 0 \\ 0 & m \end{bmatrix}; \end{matrix} \quad \mathbf{C} = \begin{bmatrix} 2c_v e^2 + c_d l^2 & -c_d l \\ -c_d l & c_d \end{bmatrix}; \quad \mathbf{K} = \begin{bmatrix} 2k_v d^2 + k_d l^2 & -k_d l \\ -k_d l & k_d \end{bmatrix};$$

$$\mathbf{x} = \begin{bmatrix} \alpha \\ x \end{bmatrix}; \quad \mathbf{F} = \begin{bmatrix} m_R \mu \Omega^2 \sqrt{a^2 + b^2} \\ 0 \end{bmatrix} \cos \Omega t$$

2. The expression for the amplitudes of the forced vibrations of the system along the coordinates x and α
3. The expression for the force transmitted to foundation by the damper c_v .

Problem 40

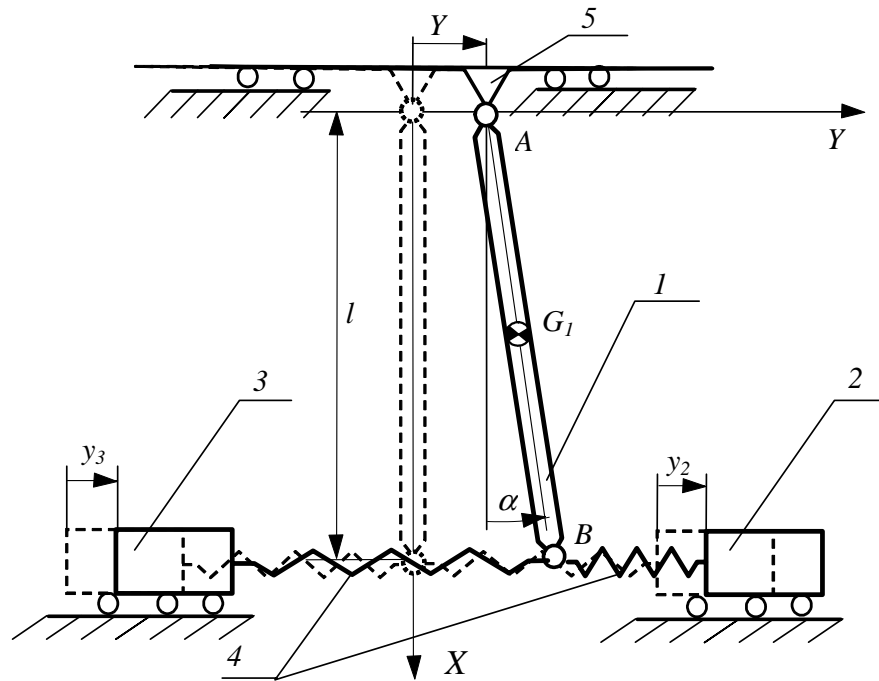

Figure 56

The uniform rod 1 of mass m and length l shown in Fig. 56 is hinged at the point A to the support 5. The support 5 moves along the horizontal axis Y according to the following function

$$Y = a \cos \omega t$$

The lower end of the rod is connected to the blocks 2 and 3 by means of two springs 4 each of stiffness k . The blocks mass is m_2 and m_3 respectively. The system performs small oscillation in the vertical plane XY . It possesses three degrees of freedom and the three independent coordinates are denoted by y_2 and y_3 .

Produce:

1. The differential equation of small oscillations of the and present it in the following matrix form.

$$\mathbf{M}\ddot{\mathbf{x}} + \mathbf{C}\dot{\mathbf{x}} + \mathbf{K}\mathbf{x} = \mathbf{F}$$

2. The expression for the amplitudes of the forced vibrations of the system.
3. The expression for the driving force that must be applied to the point A in order to assure the assumed motion $Y(t)$.

Solution

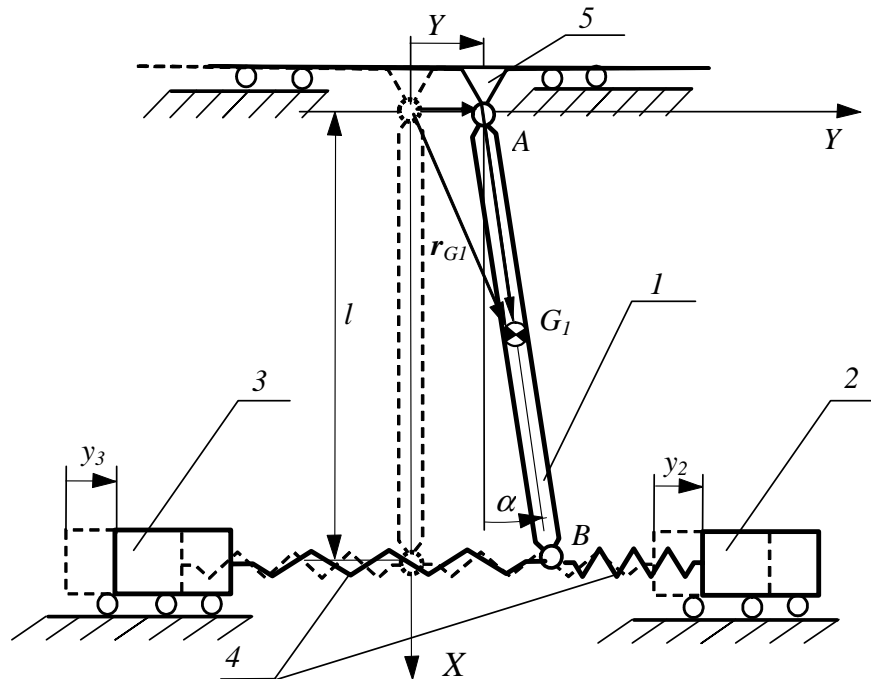

Figure 57

Motion of the system is governed by the Lagrange equations.

$$\begin{aligned} \frac{d}{dt} \frac{\partial T}{\partial \dot{\alpha}} - \frac{\partial T}{\partial \alpha} + \frac{\partial V}{\partial \alpha} &= 0 \\ \frac{d}{dt} \frac{\partial T}{\partial \dot{y}_2} - \frac{\partial T}{\partial y_2} + \frac{\partial V}{\partial y_2} &= 0 \\ \frac{d}{dt} \frac{\partial T}{\partial \dot{y}_3} - \frac{\partial T}{\partial y_3} + \frac{\partial V}{\partial y_3} &= 0 \end{aligned} \quad (2.246)$$

To produce the kinetic energy function T associated with the rod 1, let us develop the position vector of its centre of gravity G_1 .

$$\mathbf{r}_{G1} = \mathbf{J} \left(Y + \frac{l}{2} \sin \alpha \right) + \mathbf{I} \left(\frac{l}{2} \cos \alpha \right) \quad (2.247)$$

Its first derivative provide us with the absolute velocity of the centre of gravity.

$$\dot{\mathbf{r}}_{G1} = \mathbf{J} \left(\dot{Y} + \frac{l}{2} \dot{\alpha} \cos \alpha \right) + \mathbf{I} \left(-\frac{l}{2} \dot{\alpha} \sin \alpha \right) \quad (2.248)$$

Hence, the kinetic energy of the rod is

$$T_1 = \frac{1}{2} m \left(\left(\dot{Y} + \frac{l}{2} \dot{\alpha} \cos \alpha \right)^2 + \left(-\frac{l}{2} \dot{\alpha} \sin \alpha \right)^2 \right) + \frac{1}{2} I_{G1} \dot{\alpha}^2 \quad (2.249)$$

Since the kinetic energy of the blocks 2 and 3 is as follows

$$T_2 = \frac{1}{2}m_2\dot{y}_2^2 \quad T_3 = \frac{1}{2}m_3\dot{y}_3^2 \quad (2.250)$$

the total kinetic energy of the whole system is

$$T = T_1 + T_2 + T_3 = \frac{1}{2}m\dot{Y}^2 + \frac{1}{2}ml\dot{Y}\dot{\alpha}\cos\alpha + \frac{1}{8}ml^2\dot{\alpha}^2 + \frac{1}{2}I_{G1}\dot{\alpha}^2 + \frac{1}{2}m_2\dot{y}_2^2 + \frac{1}{2}m_3\dot{y}_3^2 \quad (2.251)$$

The potential energy of the springs 4 is

$$V_s = \frac{1}{2}k_2(y_2 - Y - l\sin\alpha)^2 + \frac{1}{2}k_3(-y_3 + Y + l\sin\alpha)^2 \quad (2.252)$$

The potential energy due to gravitation is

$$V_g = -mgr_{G1Y} = -mg\frac{l}{2}\cos\alpha \quad (2.253)$$

Hence, the total potential energy is

$$V = V_s + V_g = \frac{1}{2}k_2(y_2 - Y - l\sin\alpha)^2 + \frac{1}{2}k_3(-y_3 + Y + l\sin\alpha)^2 - mg\frac{l}{2}\cos\alpha \quad (2.254)$$

Introducing the expressions 2.251 and 2.254 into equations 2.246 one can get the required equation in the following matrix form.

$$\mathbf{M}\ddot{\mathbf{x}} + \mathbf{C}\dot{\mathbf{x}} + \mathbf{K}\mathbf{x} = \mathbf{F}\cos\omega t \quad (2.255)$$

where

$$\mathbf{M} = \begin{bmatrix} I_G + \frac{1}{4}ml^2 & 0 & 0 \\ 0 & m_2 & 0 \\ 0 & 0 & m_3 \end{bmatrix}; \quad \mathbf{C} = \mathbf{0}; \quad \mathbf{K} = \begin{bmatrix} \frac{1}{2}mgl + k_2l^2 + k_3l^2 & -k_2l & -k_3l \\ -k_2l & k_2 & 0 \\ -k_3l & 0 & k_3 \end{bmatrix}$$

$$\mathbf{F} = \begin{bmatrix} -\frac{1}{2}m\ddot{Y} - (k_2l + k_3l)Y \\ k_2Y \\ k_3Y \end{bmatrix} = \begin{bmatrix} +\frac{1}{2}ml\omega^2 - a(k_2l + k_3l) \\ k_2a \\ k_3a \end{bmatrix}; \quad \mathbf{x} = \begin{bmatrix} \alpha \\ y_2 \\ y_3 \end{bmatrix} \quad (2.256)$$

To verify the above equations of motion let us employ the Newton-Euler method for modeling of the system considered. The free body diagrams are shown in Fig. 58

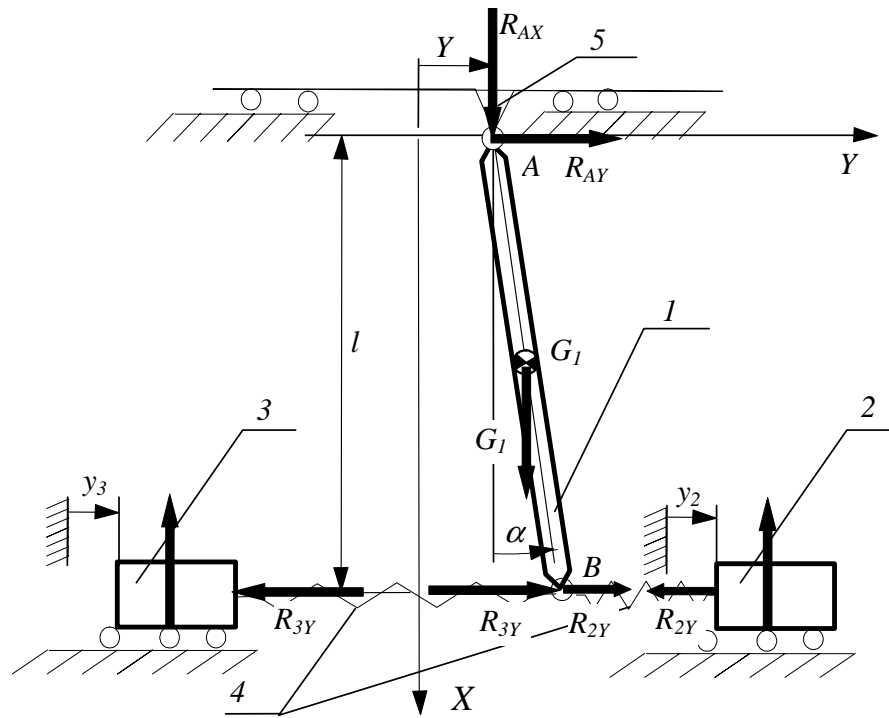

Figure 58

For the rod one can produce the following two equations

$$\begin{aligned} I_G \ddot{\alpha} &= -\frac{1}{2} R_{AY} l + \frac{1}{2} R_{2Y} l + \frac{1}{2} R_{3Y} l \\ m a_{G1Y} &= R_{AY} + R_{2Y} + R_{3Y} \end{aligned} \quad (2.257)$$

The second equation can be used for determination of the unknown interaction force R_{AY} .

$$R_{AY} = m a_{G1Y} - R_{2Y} - R_{3Y} \quad (2.258)$$

Introduction of the above expression into the first equation of 2.257 gives

$$I_G \ddot{\alpha} = -\frac{1}{2} l m a_{G1Y} + R_{2Y} l + R_{3Y} l \quad (2.259)$$

In the latest equation a_{G1Y} stands for the component Y of the absolute acceleration of the centre of gravity G_1 . It can be obtained by differentiation of the absolute velocity vector 2.247.

$$\ddot{\mathbf{r}}_{G1} = \mathbf{J}(\ddot{Y} + \frac{l}{2} \ddot{\alpha} \cos \alpha - \frac{l}{2} \dot{\alpha}^2 \sin \alpha) + \mathbf{I}(-\frac{l}{2} \ddot{\alpha} \sin \alpha - \frac{l}{2} \dot{\alpha}^2 \cos \alpha) \quad (2.260)$$

Hence

$$a_{G1Y} = \ddot{Y} + \frac{l}{2} \ddot{\alpha} \cos \alpha - \frac{l}{2} \dot{\alpha}^2 \sin \alpha \quad (2.261)$$

After linearization

$$a_{G1Y} = \ddot{Y} + \frac{l}{2} \ddot{\alpha} \quad (2.262)$$

Introduction of 2.262 into 2.259 results in the following equation

$$I_G \ddot{\alpha} = -\frac{1}{2}lm(\ddot{Y} + \frac{l}{2}\ddot{\alpha}) + R_{2Y}l + R_{3Y}l \quad (2.263)$$

The interaction forces between the rod and the springs are can be expressed as follows

$$R_{2Y} = k_2(y_2 - Y - \alpha l); \quad R_{3Y} = k_3(y_3 - Y - \alpha l) \quad (2.264)$$

Introducing them into equation 2.263 one can obtain

$$(I_G + \frac{1}{4}ml^2)\ddot{\alpha} + k_2l^2\alpha + k_3l^2\alpha - k_2ly_2 - k_3ly_3 = -\frac{1}{2}lm\ddot{Y} - k_2lY - k_3lY \quad (2.265)$$

The Newton's law if apply to the blocks 2 and 3 yields

$$\begin{aligned} m_2\ddot{y}_2 &= -R_{2Y} \\ m_3\ddot{y}_3 &= -R_{3Y} \end{aligned} \quad (2.266)$$

Since the interaction forces are defined by 2.264 we have

$$\begin{aligned} m_2\ddot{y}_2 + k_2y_2 - k_2l\alpha &= k_2Y \\ m_3\ddot{y}_3 + k_3y_3 + k_3l\alpha &= k_3Y \end{aligned} \quad (2.267)$$

Hence, the governing equations are

$$\begin{aligned} (I_G + \frac{1}{4}ml^2)\ddot{\alpha} + k_2l^2\alpha + k_3l^2\alpha - k_2ly_2 - k_3ly_3 &= -\frac{1}{2}lm\ddot{Y} - k_2lY - k_3lY \\ m_2\ddot{y}_2 + k_2y_2 - k_2l\alpha &= k_2Y \\ m_3\ddot{y}_3 + k_3y_3 + k_3l\alpha &= k_3Y \end{aligned} \quad (2.268)$$

They are identical with 2.255.

$$\mathbf{M}\ddot{\mathbf{x}} + \mathbf{K}\mathbf{x} = \mathbf{F} \cos \omega t \quad (2.269)$$

The amplitudes of the forced vibration could be obtained from the particular solution of the above equation. It can be predicted as

$$\mathbf{x} = \mathbf{A} \cos \omega t \quad (2.270)$$

Introducing it into the equation of motion we have

$$(-\omega^2\mathbf{M} + \mathbf{K})\mathbf{A} = \mathbf{F} \quad (2.271)$$

The wanted vector of the amplitudes of the system forced vibrations is

$$\mathbf{A} = (-\omega^2\mathbf{M} + \mathbf{K})^{-1}\mathbf{F} = \begin{bmatrix} A_\alpha \\ A_{y2} \\ A_{y3} \end{bmatrix} \quad (2.272)$$

Now, the interaction force R_{AY} can be produced as an explicit function of time from 2.258

$$\begin{aligned}
 R_{AY} &= ma_{G1Y} - R_{2Y} - R_{3Y} \\
 &= m \left(\ddot{Y} + \frac{l}{2} \ddot{\alpha} \right) - k_2(y_2 - Y - \alpha l) - k_3(y_3 - Y - \alpha l) \\
 &= m \left(-a\omega^2 - \frac{l}{2} A_\alpha \omega^2 \right) \cos \omega t + \\
 &\quad -k_2(A_{y2} - a - A_\alpha l) \cos \omega t - k_3(A_{y3} - a - A_\alpha l) \cos \omega t \\
 &= \left(m \left(-a - \frac{l}{2} A_\alpha \right) \omega^2 - k_2(A_{y2} - a - A_\alpha l) - k_3(A_{y3} - a - A_\alpha l) \right) \cos \omega t \\
 &= |R_{AY}| \cos \omega t
 \end{aligned}
 \tag{2.273}$$

where $|R_{AY}| = \left| m \left(-a - \frac{l}{2} A_\alpha \right) \omega^2 - k_2(A_{y2} - a - A_\alpha l) - k_3(A_{y3} - a - A_\alpha l) \right|$ is the amplitude of the interaction force.

2.3 ENGINEERING APPLICATIONS

2.3.1 Balancing of rotors

Let us consider a rigid rotor that rotates with an angular velocity ω about the axis $A - A$ (see Fig. 59).

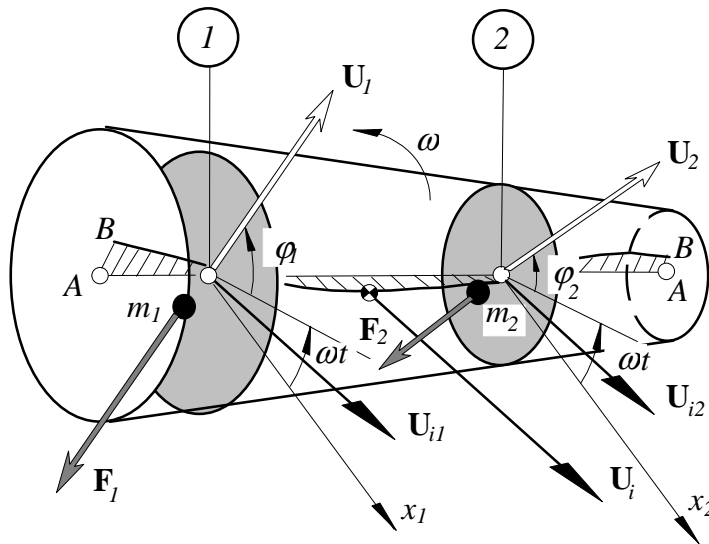

Figure 59

In a general case, due to the limited accuracy of manufacturing, the centres of gravity of the individual cross-sections do not have to coincide with this axis of rotation. They are distributed along, usually unknown, line $B - B$. It follows that due to rotation of this body at each cross-section i there exists the centrifugal force U_i (see Fig. 59). Each of these forces can be replaced by two forces U_{i1} and U_{i2} acting in

two arbitrarily chosen planes. Each of them is perpendicular to the axis of rotation, therefore their resultants \mathbf{U}_1 and \mathbf{U}_2 are perpendicular to the axis of rotation too. Hence, one can eliminate this unbalance of the rotor by means of two weights of mass m_1 and m_2 attached at such a position that the centrifugal forces \mathbf{F}_1 and \mathbf{F}_2 balance the resultant forces \mathbf{U}_1 and \mathbf{U}_2 . The process of searching for magnitude of the unbalance forces \mathbf{U}_1 and \mathbf{U}_2 and their phases φ_1 and φ_2 is called *balancing*. The balancing of a rotor can be performed with help of a specially design machines before it is installed or can be carried out after its installation 'in its own bearings'. The second approach for balancing rotors is consider in this section.

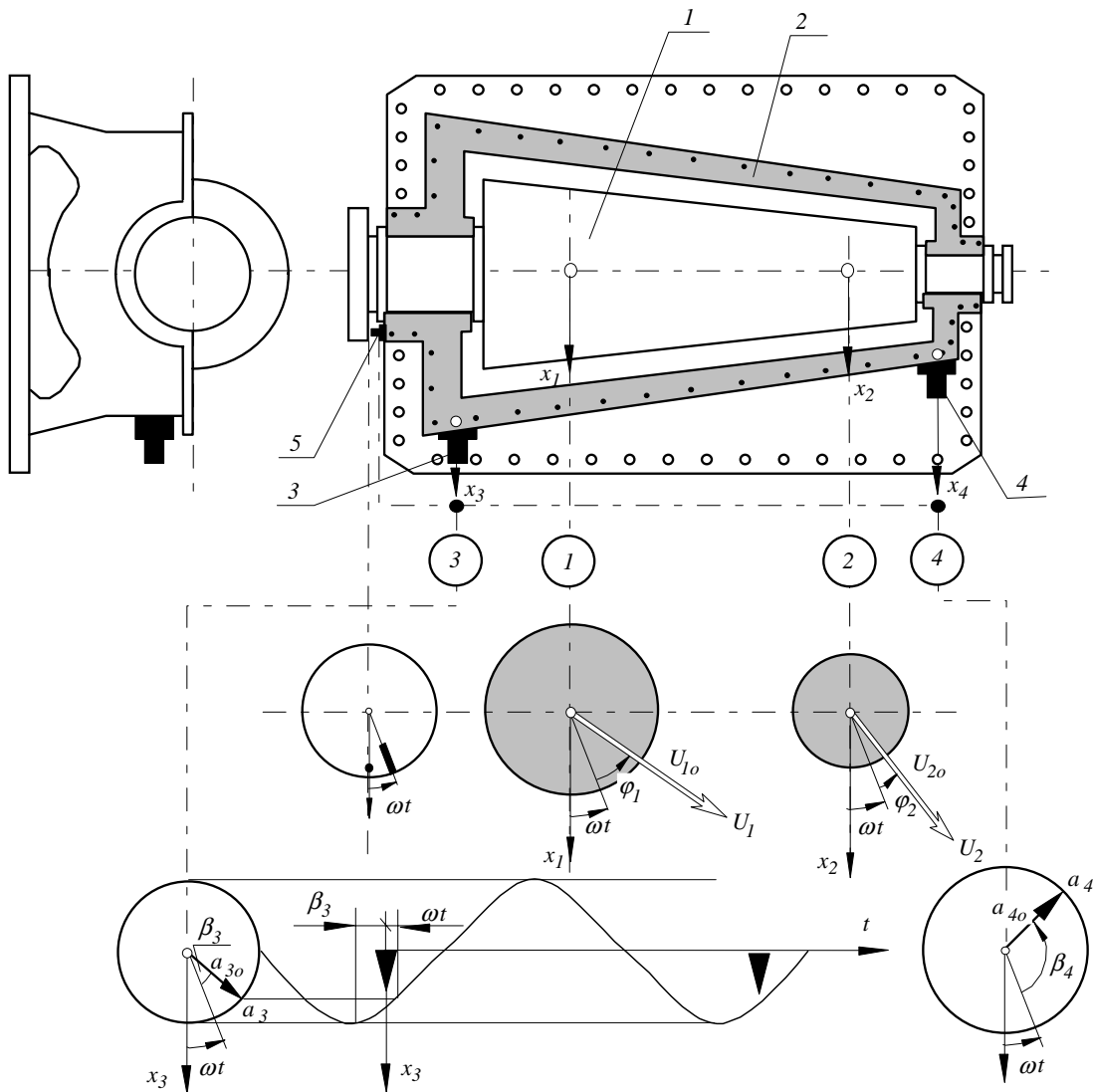

Figure 60

Let us consider the rotating machine shown in Fig. 60. According to the above discussion, if the rotor of this machine can be approximated by a rigid body, the unbalance forces can be represented by forces U_1 and U_2 in two arbitrarily chosen plane. These two arbitrarily chosen planes, denoted in Fig. 60 by numbers 1 and 2, are

called *balancing plane*. Although the selection of the balancing planes is arbitrary, there are numerous practical considerations for proper selection. For long rotors, for example, the balancing planes should be chosen as far apart as possible. Furthermore, these plane should offer an easy access and allow additional weights to be attached. These unbalance forces excite vibrations of this machine. Let us arrange for these vibrations to be recorded in two arbitrarily chosen planes. These planes, marked in Fig. 60 by numbers 3 and 4, are called *measurement planes*. Let a_3 and a_4 be the complex displacements measured in the measurement plasen along the coordinates x_3 and x_4 with help of the two transducers 3 and 4. The transducer 5, which is called *key phasor*, creates a timing reference mark on the rotor. This mark, shown in Fig. 60 by \blacktriangle , allows the phases of the unbalance forces (φ_1, φ_2) and the phases of the recorded displacements (β_1, β_2) to be measured. The equation 2.96 offers the relationship between the unknown unbalance forces U_1 and U_2 and the measured displacements a_3 and a_4 .

$$\begin{bmatrix} a_3 \\ a_4 \end{bmatrix} = \begin{bmatrix} R_{31}(i\omega) & R_{32}(i\omega) \\ R_{41}(i\omega) & R_{42}(i\omega) \end{bmatrix} \begin{bmatrix} U_1 \\ U_2 \end{bmatrix} \tag{2.274}$$

where

$$a_3 = a_{3o}e^{i\beta_3}, \quad a_4 = a_{4o}e^{i\beta_4}, \quad U_1 = U_{1o}e^{i\varphi_1}, \quad U_2 = U_{2o}e^{i\varphi_2} \tag{2.275}$$

If the transfer functions $R_{i,j}(i\omega)$ would be known, this relation would allow the unknown magnitudes of the unbalance as well as their phases to be determined. In order to identify the transfer functions two additional tests are required.

Test (1)

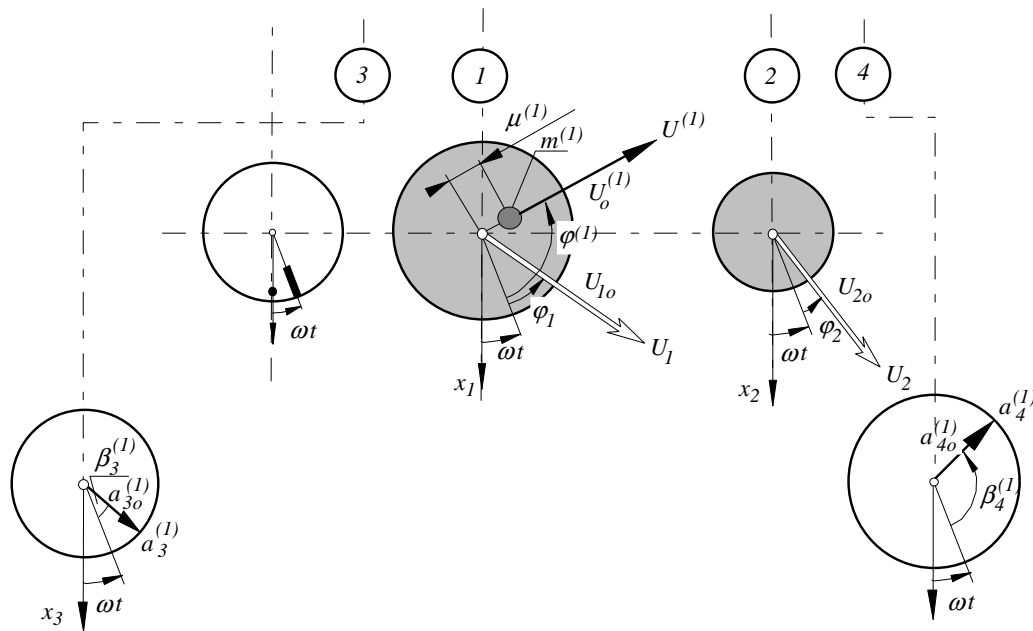

Figure 61

An additional trial weight of mass $m^{(1)}$ (see Fig 61) is attached in the balancing plane 1 at the known (with respect to the key phasor's mark) phase $\varphi^{(1)}$ and the know distance $\mu^{(1)}$. The system is now excited by both the residual unbalance forces (U_1 and U_2) and the centrifugal force produced by the trial weight $U^{(1)}$. The amplitude of this force $U^{(1)}$ is

$$U_o^{(1)} = m^{(1)}\mu^{(1)}\omega^2 \tag{2.276}$$

The response of the system is recorded in both measurement planes so the amplitudes $a_{3o}^{(1)}$ and $a_{4o}^{(1)}$ as well as the phases $\beta_3^{(1)}$ and $\beta_4^{(1)}$ can be obtained. There is the following relationship between the measured parameters and the transfer functions.

$$\begin{bmatrix} a_3^{(1)} \\ a_4^{(1)} \end{bmatrix} = \begin{bmatrix} R_{31}(i\omega) & R_{32}(i\omega) \\ R_{41}(i\omega) & R_{42}(i\omega) \end{bmatrix} \begin{bmatrix} U_1 + U^{(1)} \\ U_2 \end{bmatrix} \tag{2.277}$$

$$a_3^{(1)} = a_{3o}^{(1)} e^{i\beta_3^{(1)}}, \quad a_4^{(1)} = a_{4o}^{(1)} e^{i\beta_4^{(1)}}, \quad U_1 = U_{1o} e^{i\varphi_1}, \quad U_2 = U_{2o} e^{i\varphi_2}, \quad U^{(1)} = U_o^{(1)} e^{i\varphi^{(1)}} \tag{2.278}$$

Test (2)

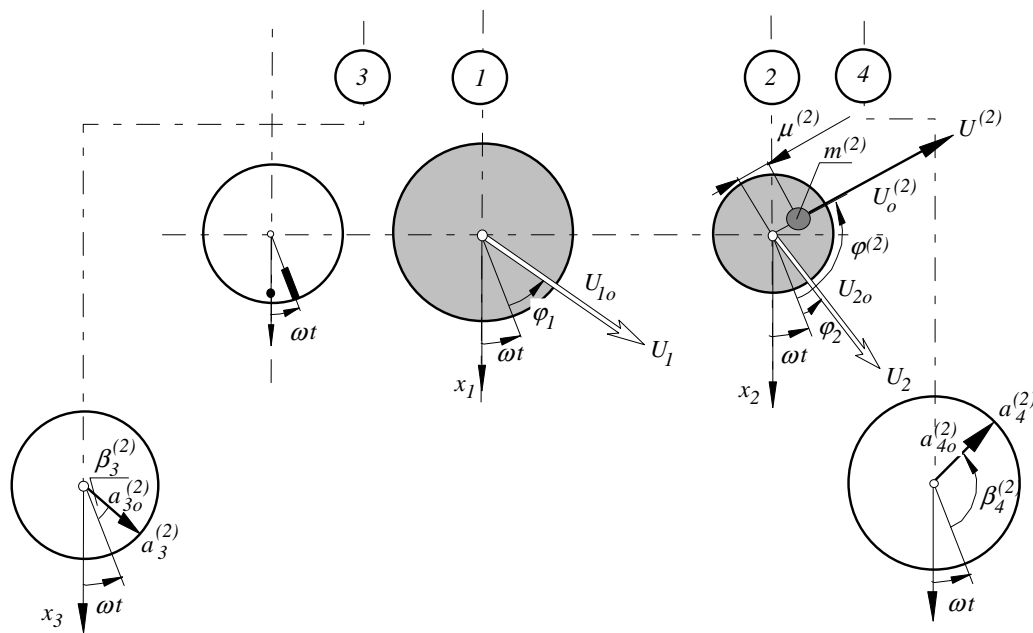

Figure 62

An additional trial weight of mass $m^{(2)}$ (see Fig 62) is attached in the balancing plane 2 at the known (with respect to the key phasor's mark) phase $\varphi^{(2)}$ and the know distance $\mu^{(2)}$. The system is now excited by both the residual unbalance forces (U_1 and U_2) and the centrifugal force produced by the trial weight $U^{(2)}$. The amplitude of this force $U^{(2)}$ is

$$U_o^{(2)} = m^{(2)}\mu^{(2)}\omega^2 \tag{2.279}$$

The response of the system is recorded in both measurement planes so the amplitudes $a_{3o}^{(2)}$ and $a_{4o}^{(2)}$ as well as the phases $\beta_3^{(2)}$ and $\beta_4^{(2)}$ can be obtained. There is the following

relationship between the measured parameters and the transfer functions.

$$\begin{bmatrix} a_3^{(2)} \\ a_4^{(2)} \end{bmatrix} = \begin{bmatrix} R_{31}(i\omega) & R_{32}(i\omega) \\ R_{41}(i\omega) & R_{42}(i\omega) \end{bmatrix} \begin{bmatrix} U_1 \\ U_2 + U^{(2)} \end{bmatrix} \quad (2.280)$$

$$a_3^{(2)} = a_{3o}^{(2)} e^{i\beta_3^{(2)}}, \quad a_4^{(2)} = a_{4o}^{(2)} e^{i\beta_4^{(2)}}, \quad U_1 = U_{1o} e^{i\varphi_1}, \quad U_2 = U_{2o} e^{i\varphi_2}, \quad U^{(2)} = U_o^{(2)} e^{i\varphi^{(2)}} \quad (2.281)$$

The formulated equations 2.274, 2.277 and 2.280 allow the unknown transfer functions and the wanted unbalances U_1 and U_2 to be computed. To achieve that let us subtract the equations 2.274 from 2.277

$$\begin{aligned} \left(\begin{bmatrix} a_3^{(1)} \\ a_4^{(1)} \end{bmatrix} - \begin{bmatrix} a_3 \\ a_4 \end{bmatrix} \right) &= \begin{bmatrix} R_{31}(i\omega) & R_{32}(i\omega) \\ R_{41}(i\omega) & R_{42}(i\omega) \end{bmatrix} \left(\begin{bmatrix} U_1 + U^{(1)} \\ U_2 \end{bmatrix} - \begin{bmatrix} U_1 \\ U_2 \end{bmatrix} \right) \\ \begin{bmatrix} a_3^{(1)} - a_3 \\ a_4^{(1)} - a_4 \end{bmatrix} &= \begin{bmatrix} R_{31}(i\omega) & R_{32}(i\omega) \\ R_{41}(i\omega) & R_{42}(i\omega) \end{bmatrix} \begin{bmatrix} U^{(1)} \\ 0 \end{bmatrix} \\ \begin{bmatrix} a_3^{(1)} - a_3 \\ a_4^{(1)} - a_4 \end{bmatrix} &= \begin{bmatrix} R_{31}(i\omega)U^{(1)} \\ R_{41}(i\omega)U^{(1)} \end{bmatrix} \\ R_{31}(i\omega) &= \frac{a_3^{(1)} - a_3}{U^{(1)}} = \frac{a_{3o}^{(1)} e^{i\beta_3^{(1)}} - a_{3o} e^{i\beta_3}}{U_o^{(1)} e^{i\varphi^{(1)}}} \\ R_{41}(i\omega) &= \frac{a_4^{(1)} - a_4}{U^{(1)}} = \frac{a_{4o}^{(1)} e^{i\beta_4^{(1)}} - a_{4o} e^{i\beta_4}}{U_o^{(1)} e^{i\varphi^{(1)}}} \end{aligned} \quad (2.282)$$

Similarly, if one subtracts equations 2.274 from 2.280 one can get

$$\begin{aligned} R_{32}(i\omega) &= \frac{a_3^{(2)} - a_3}{U^{(2)}} = \frac{a_{3o}^{(2)} e^{i\beta_3^{(2)}} - a_{3o} e^{i\beta_3}}{U_o^{(2)} e^{i\varphi^{(2)}}} \\ R_{42}(i\omega) &= \frac{a_4^{(2)} - a_4}{U^{(2)}} = \frac{a_{4o}^{(2)} e^{i\beta_4^{(2)}} - a_{4o} e^{i\beta_4}}{U_o^{(2)} e^{i\varphi^{(2)}}} \end{aligned} \quad (2.283)$$

Now, the wanted complex imbalances U_1 and U_2 in the plane 1 and 2 may be computed from the equation 2.274

$$\begin{bmatrix} U_1 \\ U_2 \end{bmatrix} = \begin{bmatrix} R_{31}(i\omega) & R_{32}(i\omega) \\ R_{41}(i\omega) & R_{42}(i\omega) \end{bmatrix}^{-1} \begin{bmatrix} a_3 \\ a_4 \end{bmatrix} \quad (2.284)$$

where a_3 and a_4 represent the know response of the system without the additional weights.

$$\begin{bmatrix} U_1 \\ U_2 \end{bmatrix} = \begin{bmatrix} R_{31}(i\omega) & R_{32}(i\omega) \\ R_{41}(i\omega) & R_{42}(i\omega) \end{bmatrix}^{-1} \begin{bmatrix} a_{3o} e^{i\beta_3} \\ a_{4o} e^{i\beta_4} \end{bmatrix} = \begin{bmatrix} U_{1o} e^{i\varphi_1} \\ U_{2o} e^{i\varphi_2} \end{bmatrix} \quad (2.285)$$

The amplitudes U_{1o} and U_{2o} determine the weights m_1 and m_2 that should be attached in the balancing planes

$$m_1 = \frac{U_1}{r_1 \omega^2}$$

$$m_2 = \frac{U_2}{r_2 \omega^2} \tag{2.286}$$

These weights, to balance the rotor, should be placed at angular position (see Fig. 63)

$$\beta_1 = 180^\circ + \varphi_1$$

$$\beta_2 = 180^\circ + \varphi_2 \tag{2.287}$$

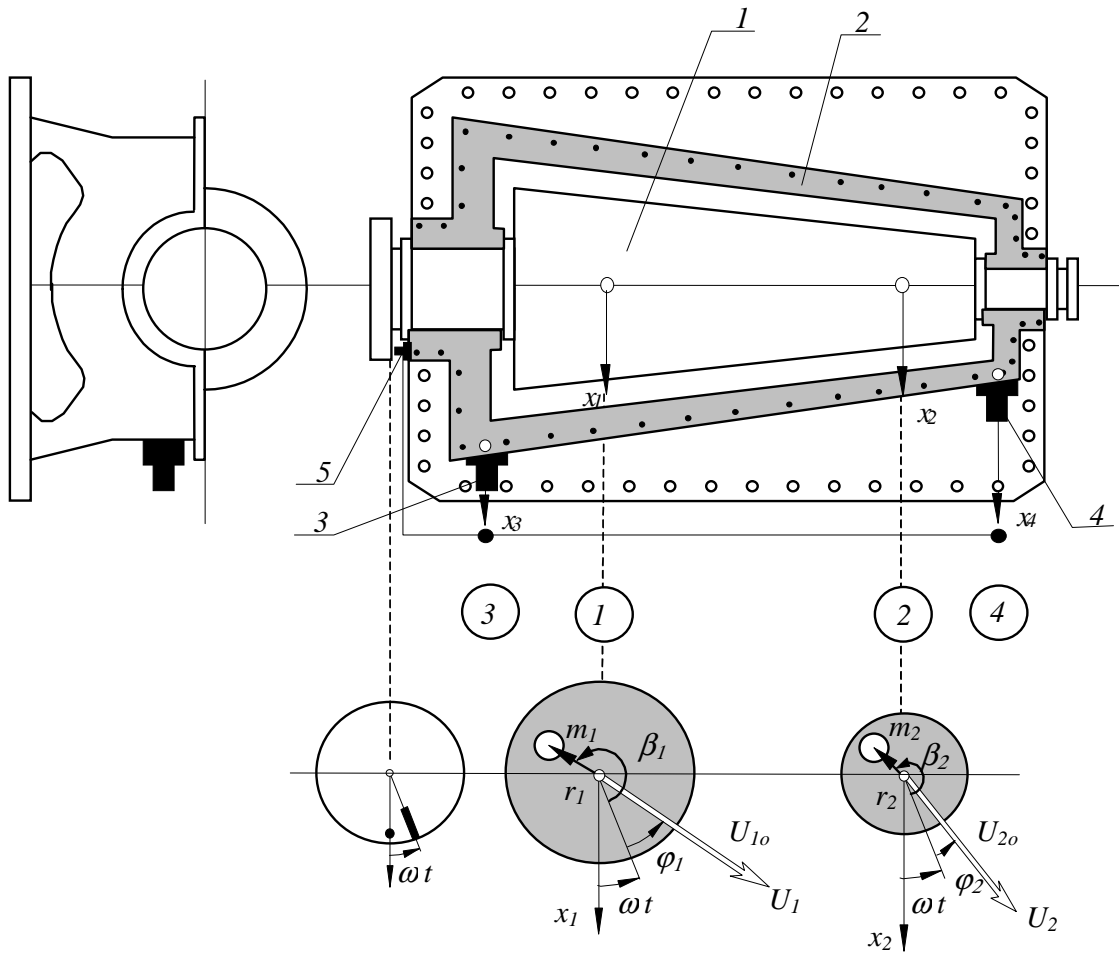

Figure 63

2.3.2 Dynamic absorber of vibrations

Let us consider vibration of the ventilator shown in Fig. 64a). Vibration of this ventilator are due to the imbalance u if its rotor.

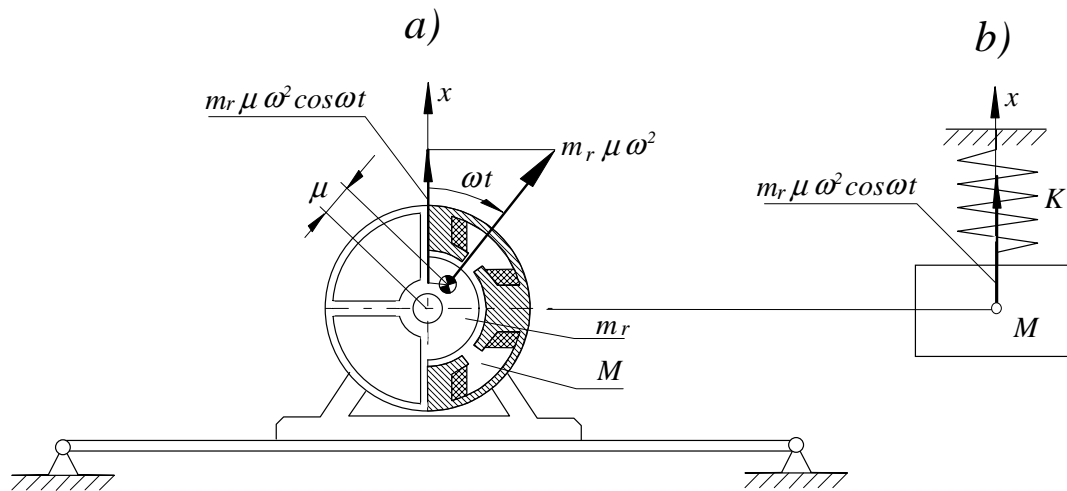

Figure 64

Let us assume that the system has the following parameters:

$M = 100$ kg - total mass of the ventilator

$m_r = 20$ kg - mass of rotor of the ventilator

$K = 9000000$ N/m - stiffness of the supporting beam

$\omega = 314$ rad/s the ventilator's operating speed

$\mu = .0001$ m - distance between the axis of rotation and the centre of gravity

$u = m_r \mu = 20 \cdot .0001 = .002$ kgm - imbalance of the rotor

The natural frequency of the system is

$$\omega_n = \sqrt{\frac{K}{M}} = \sqrt{\frac{9000000}{100}} = 300 \quad (2.288)$$

Hence, within the range of the rotor angular speed $0 < \omega < 500$ the system can be approximated by system with one degree of freedom. Its physical model is shown in Fig. 64b). The following mathematical model

$$M\ddot{x} + Kx = m_r \mu \omega^2 \cos \omega t \quad (2.289)$$

$$\ddot{x} + \omega_n^2 x = q \cos \omega t \quad (2.290)$$

$$q = \frac{u}{M} \omega^2 = \frac{0.002}{100} \omega^2 = .00002 \omega^2 \quad (2.291)$$

allows the amplitude of the forced vibrations of the ventilator A to be predicted.

$$A = \left| \frac{q}{\omega_n^2 - \omega^2} \right| = \left| \frac{.00002 \omega^2}{300^2 - \omega^2} \right| \quad (2.292)$$

Its values, as a function of the angular speed of the rotor is shown in Fig. 65

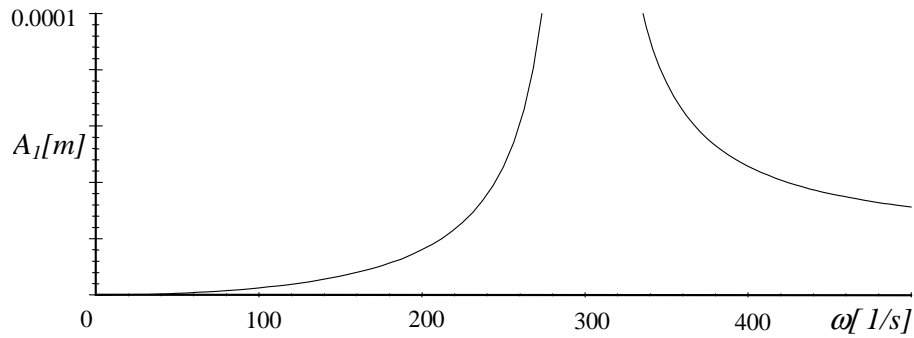

Figure 65

As it can be seen from this diagram, the ventilator develops large vibration in vicinity of its working speed $\omega = 314$ rad/s and has to pass the critical speed during the run up. Such a solution is not acceptable. One of a possible way of reducing these vibration is to furnish the ventilator with the absorber of vibration shown in fig 66

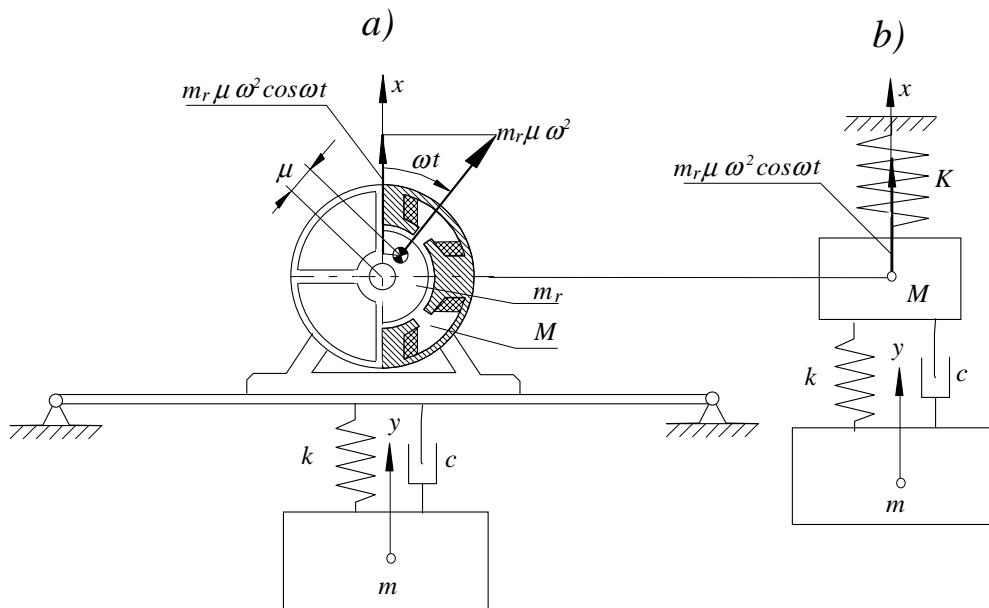

Figure 66

It comprises block of mass m , elastic element of stiffness k and damper of the damping coefficient c . Application of the Newton's - Euler's method, results in the following mathematical model.

$$\begin{aligned} M\ddot{x} + (K + k)x - ky + c\dot{x} - c\dot{y} &= u\omega^2 \cos \omega t \\ m\ddot{y} - kx + ky - c\dot{x} + c\dot{y} &= 0 \end{aligned} \tag{2.293}$$

Its matrix form is

$$\begin{bmatrix} M & 0 \\ 0 & m \end{bmatrix} \begin{bmatrix} \ddot{x} \\ \ddot{y} \end{bmatrix} + \begin{bmatrix} +c & -c \\ -c & +c \end{bmatrix} \begin{bmatrix} \dot{x} \\ \dot{y} \end{bmatrix} + \begin{bmatrix} K+k & -k \\ -k & +k \end{bmatrix} \begin{bmatrix} x \\ y \end{bmatrix} = \begin{bmatrix} u\omega^2 \cos \omega t \\ 0 \end{bmatrix} \quad (2.294)$$

To analyze the forced vibrations let us introduce the complex excitation

$$\begin{aligned} & \begin{bmatrix} M & 0 \\ 0 & m \end{bmatrix} \begin{bmatrix} \ddot{x} \\ \ddot{y} \end{bmatrix} + \begin{bmatrix} +c & -c \\ -c & +c \end{bmatrix} \begin{bmatrix} \dot{x} \\ \dot{y} \end{bmatrix} + \begin{bmatrix} K+k & -k \\ -k & +k \end{bmatrix} \begin{bmatrix} x \\ y \end{bmatrix} = \\ & = \begin{bmatrix} u\omega^2 \cos \omega t + iu\omega^2 \sin \omega t \\ 0 \end{bmatrix} = \begin{bmatrix} u\omega^2 e^{i\omega t} \\ 0 \end{bmatrix} = \begin{bmatrix} u\omega^2 \\ 0 \end{bmatrix} e^{i\omega t} \end{aligned} \quad (2.295)$$

Introducing notations

$$\mathbf{m} = \begin{bmatrix} M & 0 \\ 0 & m \end{bmatrix}; \quad \mathbf{c} = \begin{bmatrix} +c & -c \\ -c & +c \end{bmatrix}; \quad \mathbf{k} = \begin{bmatrix} K+k & -k \\ -k & +k \end{bmatrix}; \quad \mathbf{q} = \begin{bmatrix} u\omega^2 \\ 0 \end{bmatrix}; \quad \mathbf{x} = \begin{bmatrix} x \\ y \end{bmatrix} \quad (2.296)$$

The above equations takes form

$$\mathbf{m}\ddot{\mathbf{x}} + \mathbf{c}\dot{\mathbf{x}} + \mathbf{k}\mathbf{x} = \mathbf{q}e^{i\omega t} \quad (2.297)$$

If one predicts the particular solution as

$$\mathbf{x} = \mathbf{A}e^{i\omega t} \quad (2.298)$$

and than introduces it into the equation 2.297 one obtains the formula for the amplitude of the forced vibration

$$\mathbf{A} = |(-\omega^2\mathbf{m} + i\omega\mathbf{c} + \mathbf{k})^{-1}\mathbf{q}| \quad (2.299)$$

Remarkable results we are getting if parameters k and m of the absorber fulfill the following relationship

$$\sqrt{\frac{k}{m}} = \omega = 314 \quad (2.300)$$

To show it let us assume

$$m = 25 \text{ kg}$$

and compute the value of the stiffness k from the formula 2.300

$$k = m\omega^2 = 25 \cdot 314^2 = 2.4649 \times 10^6 \text{ N/m}$$

Introduction of this data into equation 2.299 and the zero damping results in the following response A_1 and A_2 of the system along the coordinates x and y respectively.

$$\begin{aligned} \mathbf{A} &= \begin{bmatrix} A_1 \\ A_2 \end{bmatrix} = \\ & \left| \left(-\omega^2 \begin{bmatrix} 100 & 0 \\ 0 & 25 \end{bmatrix} + i\omega \begin{bmatrix} 0 & 0 \\ 0 & 0 \end{bmatrix} + \begin{bmatrix} 11.5 & -2.46 \\ -2.46 & 2.46 \end{bmatrix} 10^6 \right)^{-1} \begin{bmatrix} 0.002 \cdot \omega^2 \\ 0 \end{bmatrix} \right| \end{aligned} \quad (2.301)$$

Amplitude A_1 , representing vibrations of the ventilator, as a function of the angular speed of its rotor is presented in Fig. 67:

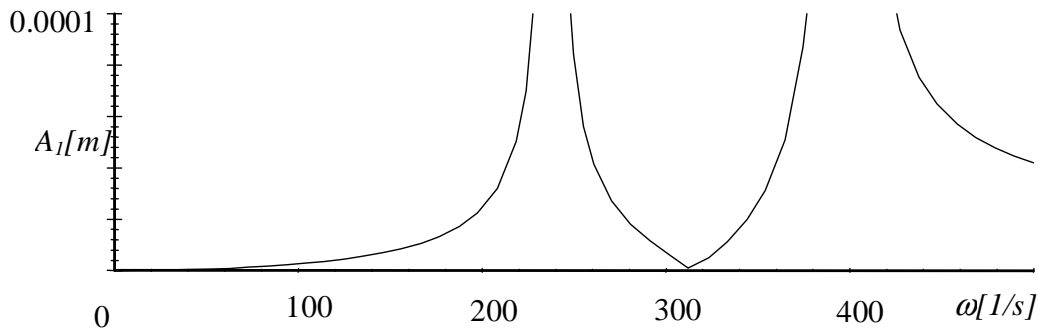

Figure 67

One can notice that the amplitude of vibration for the working speed $\omega = 314$ rad/s is equal to zero. But the ventilator still has to pass resonance in vicinity of $\omega = 240$ rad/s. To improve the dynamic response, let us analyze the influence of the damping coefficient c .

$$\begin{aligned} & \begin{bmatrix} A_1 \\ A_2 \end{bmatrix} = \\ & = \left(-\omega^2 \begin{bmatrix} 100 & 0 \\ 0 & 25 \end{bmatrix} + i\omega \begin{bmatrix} c & c \\ c & c \end{bmatrix} 10^3 + \begin{bmatrix} 11.5 & -2.46 \\ -2.46 & 2.46 \end{bmatrix} 10^6 \right)^{-1} \begin{bmatrix} 0.002 \cdot \omega^2 \\ 0 \end{bmatrix} \end{aligned} \quad (2.302)$$

The amplitudes of the forced vibration of the ventilator for different values of the damping coefficient c , computed according to the formula 2.302 are collected in the Table 1. It can be noticed, that by increasing the damping coefficient c one can lower amplitude of vibrations in all region of frequency. The best results of attenuation of vibrations can be achieved if the two local maxima are equal to each other. This case is shown in the last row of the table 1. Application of the absorber of vibrations offers a safe operation in region of the angular speed $0 < \omega < 500$ rad/s. The amplitude is less than 0.00004 m. Damping coefficient larger then 5000 results in increment of the amplitude of the ventilator's forced vibrations. If the damping tends to infinity, The relative motion is ceased and the system behaves like the undamped system with one degree of freedom.

Table 1	
$m = 25$ $k = 2.46 \times 10^6$ $c = 0$	
$m = 25$ $k = 2.46 \times 10^6$ $c = 1000$	
$m = 25$ $k = 2.46 \times 10^6$ $c = 2500$	
$m = 25$ $k = 2.46 \times 10^6$ $c = 5000$	
$m = 25$ $k = 1.75 \times 10^6$ $c = 5000$	

Chapter 3
VIBRATION OF CONTINUOUS SYSTEMS

3.1 MODELLING OF CONTINUOUS SYSTEMS

3.1.1 Modelling of strings, rods and shafts

Modelling of stings

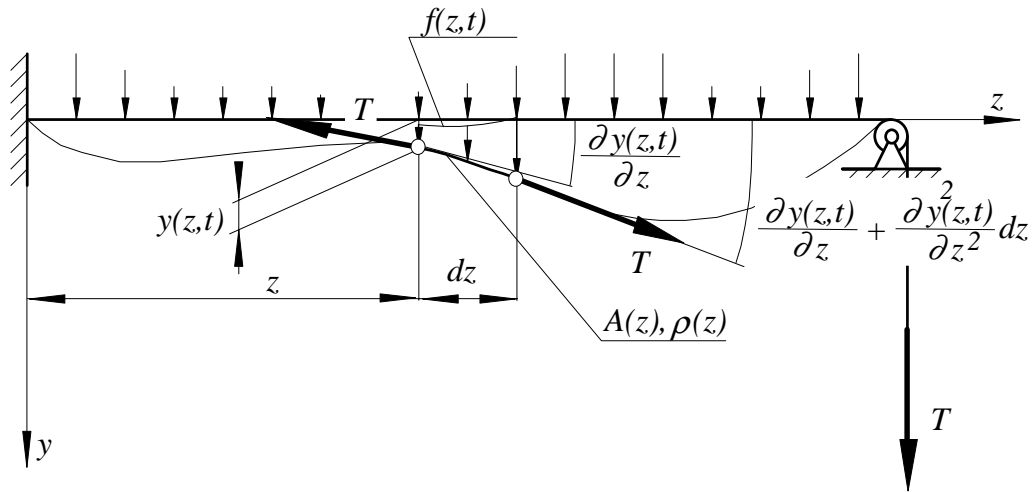

Figure 1

Strings are elastic elements that are subjected to tensile forces (see Fig. 1). It is assumed that the tensile force T is large enough to neglect its variations due to small motion of the string around its equilibrium position. In the Fig. 1 $A(z)$ stands for area of cross-section of the string and $\rho(z)$ is its density. Motion of the string is caused by the unit vertical load $f(z,t)$ that in a general case can be a function of time t and the position z . Let us consider element dz of the sting. Its position is determined by the coordinate z and its mass dm is

$$dm = A(z)\rho(z)dz \quad (3.1)$$

The free body diagram of this element is shown in Fig. 1. According to the second Newton's law

$$dm \frac{\partial^2 y(z,t)}{\partial t^2} = -T \frac{\partial y(z,t)}{\partial z} + T \left(\frac{\partial y(z,t)}{\partial z} + \frac{\partial^2 y(z,t)}{\partial z^2} dz \right) + f(z,t)dz \quad (3.2)$$

Introduction of Eq. 3.1 into Eq. 3.2 and its simplification yields

$$A(z)\rho(z)\frac{\partial^2 y(z,t)}{\partial t^2} dz - T\frac{\partial^2 y(z,t)}{\partial z^2} dz = f(z,t) dz \tag{3.3}$$

If one divide this equation by $A(z)\rho(z)dz$ it takes form

$$\frac{\partial^2 y(z,t)}{\partial t^2} - \frac{T}{A(z)\rho(z)} \frac{\partial^2 y(z,t)}{\partial z^2} = \frac{f(z,t)}{A(z)\rho(z)} \tag{3.4}$$

If the string is uniform (A and ρ are independent of z) the equation of motion is

$$\frac{\partial^2 y(z,t)}{\partial t^2} - \lambda^2 \frac{\partial^2 y(z,t)}{\partial z^2} = q(z,t) \tag{3.5}$$

where

$$\lambda^2 = \frac{T}{A\rho}; \quad q(z,t) = \frac{f(z,t)}{A\rho} \tag{3.6}$$

Modelling of rods

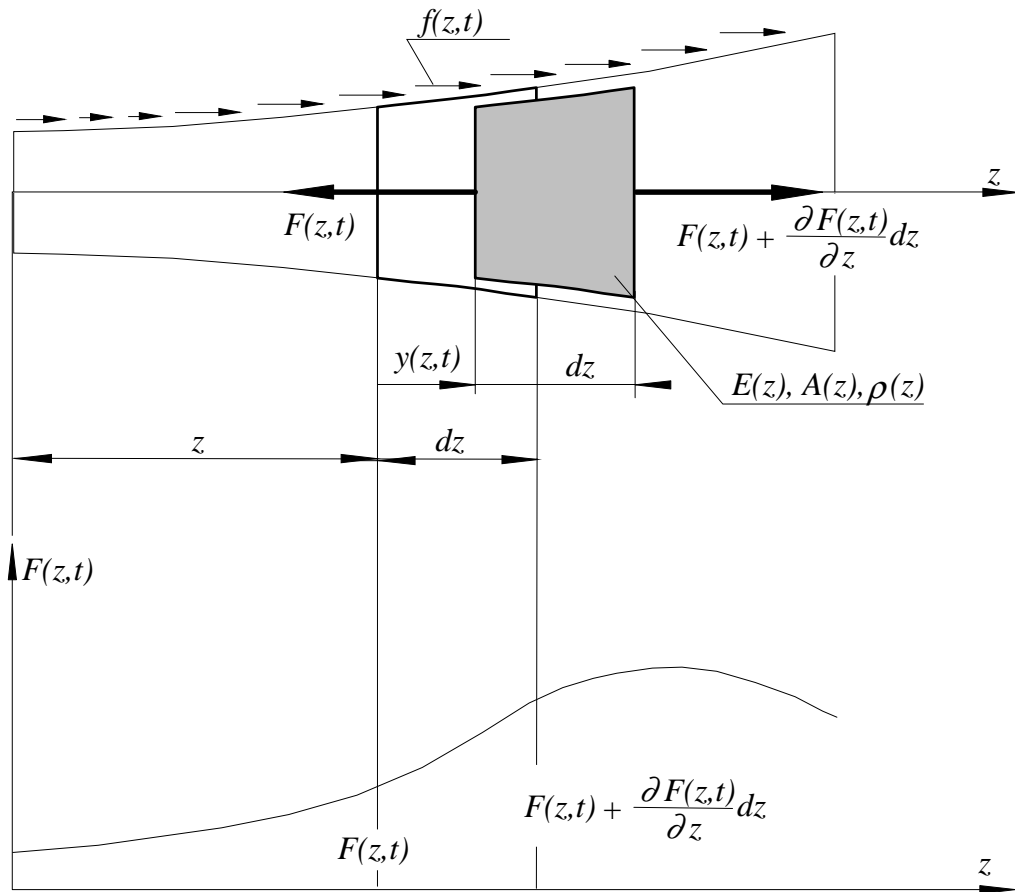

Figure 2

Rods are elastic elements that are subjected to the axial forces. Let us consider a rod of the cross-section $A(z)$, Young's modulus $E(z)$ and the density $\rho(z)$. Motion of the rod is excited by the axial force $f(z, t)$ that, in a general case, can be a function of position z and time t . Let us consider the highlighted in Fig. 2 element dz . Its instantaneous position is determined by the displacement $y(z, t)$. Application of the second Newton's law to the free body diagram of the element yields.

$$dm \frac{\partial^2 y(z, t)}{\partial t^2} = -F(z, t) + F(z, t) + \frac{\partial F(z, t)}{\partial z} dz + f(z, t) dz \quad (3.7)$$

The axial force $F(z, t)$ is related to the elongation of the element by Hooke's law

$$F(z, t) = A(z)E(z) \frac{\partial y(z, t)}{\partial z} dz = A(z)E(z) \frac{\partial y(z, t)}{\partial z} \quad (3.8)$$

Upon introducing the above expression into Eq. 3.7 one may obtain

$$dm \frac{\partial^2 y(z, t)}{\partial t^2} - \frac{\partial}{\partial z} \left(A(z)E(z) \frac{\partial y(z, t)}{\partial z} \right) dz = f(z, t) dz \quad (3.9)$$

Since mass of the element is

$$dm = A(z)\rho(z) dz \quad (3.10)$$

the equation of motion of the element is

$$A(z)\rho(z) \frac{\partial^2 y(z, t)}{\partial t^2} - \frac{\partial}{\partial z} \left(A(z)E(z) \frac{\partial y(z, t)}{\partial z} \right) = f(z, t) \quad (3.11)$$

If the rod is uniform (A, E, ρ are constant) one can get

$$\frac{\partial^2 y(z, t)}{\partial t^2} - \lambda^2 \frac{\partial^2 y(z, t)}{\partial z^2} = q(z, t) \quad (3.12)$$

where

$$\lambda^2 = \frac{E}{\rho}; \quad q(z, t) = \frac{f(z, t)}{A\rho} \quad (3.13)$$

Modelling of shafts

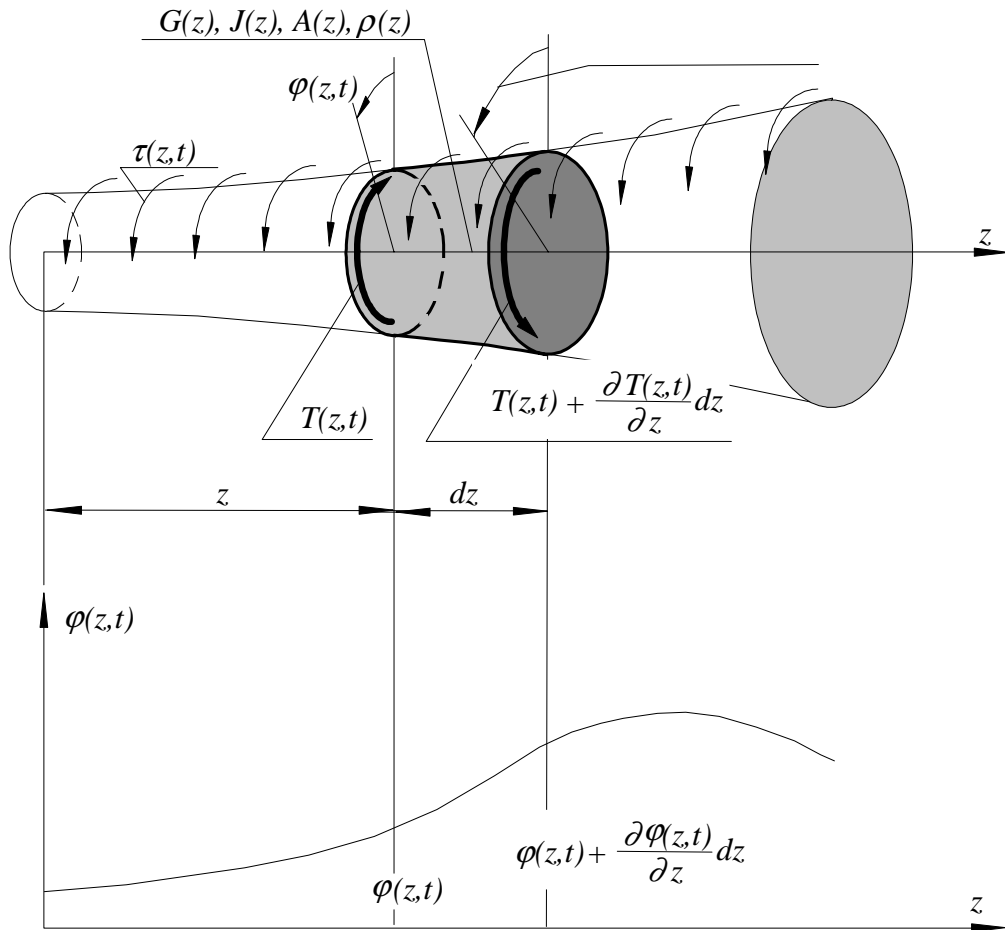

Figure 3

Shafts are elastic elements that are subjected to torques. Let us assume that the torque $\tau(z, t)$ is distributed along the axis z and is a function of time t (see Fig. 3). The shaft has the shear modulus $G(z)$, the density $\rho(z)$, the cross-section area $A(z)$ and the second moment of area $J(z)$. Due to the moment $\tau(z, t)$, the shaft performs the torsional vibrations and the instantaneous angular position of the cross-section at z is $\varphi(z, t)$. The angular position at the distance $z + dz$ is by the total differential $\frac{\partial \varphi(z, t)}{\partial z} dz$ greater. Let us consider the element dz of the shaft. Its moment of inertia about the axis z is

$$dI = \int_A r^2 dA \rho(z) dz = \rho(z) dz \int_A r^2 dA = J(z) \rho(z) dz \quad (3.14)$$

Owing to the generalized Newton's law we can write the following equation

$$dI \frac{\partial^2 \varphi(z, t)}{\partial t^2} = -T(z, t) + T(z, t) + \frac{\partial T(z, t)}{\partial z} dz + \tau(z, t) dz \quad (3.15)$$

After introduction of Eq. 3.14 and an elementary simplification the equation 3.15 takes form

$$J(z)\varrho(z)\frac{\partial^2\varphi(z,t)}{\partial t^2} - \frac{\partial T(z,t)}{\partial z} = \tau(z,t) \quad (3.16)$$

If we introduce the relationship between the torque $T(z,t)$ and the deflection $\varphi(z,t)$

$$\frac{\partial\varphi(z,t)}{\partial z}dz = \frac{T(z,t)dz}{G(z)J(z)} \quad (3.17)$$

into Eq. 3.16 we are getting

$$J(z)\varrho(z)\frac{\partial^2\varphi(z,t)}{\partial t^2} - \frac{\partial}{\partial z}G(z)J(z)\left(\frac{\partial\varphi(z,t)}{\partial z}\right) = \tau(z,t) \quad (3.18)$$

If $J(z)$, $\varrho(z)$ and $G(z)$ are constant, the equation of motion takes form.

$$\frac{\partial^2\varphi(z,t)}{\partial t^2} - \lambda^2\frac{\partial^2\varphi(z,t)}{\partial z^2} = q(z,t) \quad (3.19)$$

where

$$\lambda^2 = \frac{G}{\varrho}; \quad q(z,t) = \frac{\tau(z,t)}{J\varrho} \quad (3.20)$$

3.1.2 Modelling of beams

Beams are elastic elements that are subjected to lateral loads (forces or moments that have their vectors perpendicular to the centre line of a beam). Let us consider a beam of the second moment of area $J(z)$, cross-section $A(z)$, density $\varrho(z)$ and the Young's modulus $E(z)$. The beam performs vibrations due to the external distributed unit load $f(z,t)$. The instantaneous position of the element dz is highlighted in Fig. 4. The equation of motion of the beam in the z direction is

$$dm\frac{\partial^2y(z,t)}{\partial t^2} = +V(z,t) - V(z,t) - \frac{\partial V(z,t)}{\partial z}dz + f(z,t)dz \quad (3.21)$$

If one neglect the inertia moment associated with rotation of the element dz , sum of the moments about the point G has to be equal to zero

$$V(z,t)\frac{dz}{2} + \left(V(z,t) + \frac{\partial V(z,t)}{\partial z}dz\right)\frac{dz}{2} + M(z,t) - \left(M(z,t) + \frac{\partial M(z,t)}{\partial z}dz\right) = 0 \quad (3.22)$$

Simplification of the above equation and omission of the terms of order higher than one with respect to dz , yields the relationship between the bending moment M and the shearing force V .

$$V(z,t) = \frac{\partial M(z,t)}{\partial z} \quad (3.23)$$

Since mass of the element dz is

$$dm = A(z)\varrho(z)dz \quad (3.24)$$

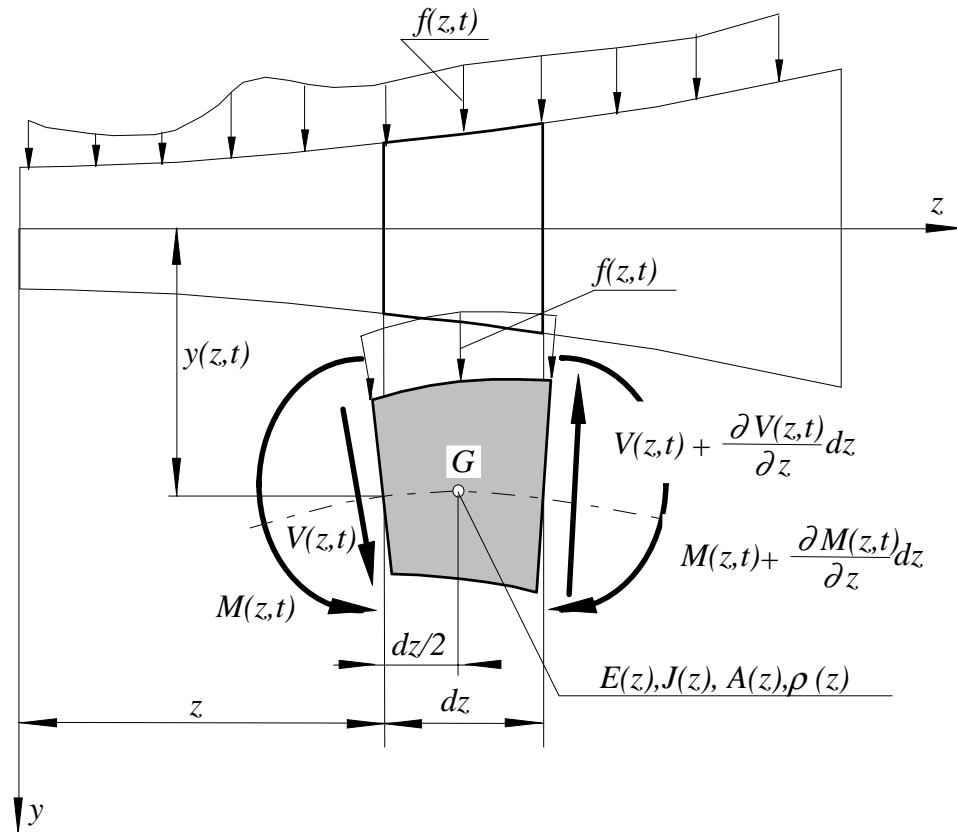

Figure 4

and taking into account Eq. 3.23, one can get the equation of motion in the following form

$$A(z)\rho(z)\frac{\partial^2 y(z, t)}{\partial t^2} + \frac{\partial M^2(z, t)}{\partial z^2} = f(z, t) \tag{3.25}$$

The mechanics of solids offers the following relationship between the deflection of the beam $y(z, t)$ and the bending moment $M(z, t)$.

$$M(z, t) = E(z)J(z)\frac{\partial^2 y(z, t)}{\partial z^2} \tag{3.26}$$

Introduction of equation 3.26 into equation 3.25 yields

$$A(z)\rho(z)\frac{\partial^2 y(z, t)}{\partial t^2} + \frac{\partial^2}{\partial z^2} \left(E(z)J(z)\frac{\partial^2 y(z, t)}{\partial z^2} \right) = f(z, t) \tag{3.27}$$

If the following parameters of the beam A , J , E and ρ are constant, motion of the beam is governed by the following equation

$$\frac{\partial^2 y(z, t)}{\partial t^2} + \lambda^2 \frac{\partial^4 y(z, t)}{\partial z^4} = q(z, t) \tag{3.28}$$

where

$$\lambda^2 = \frac{EJ}{A\rho}; \quad q(z, t) = \frac{f(z, t)}{A\rho} \tag{3.29}$$

3.2 ANALYSIS OF CONTINUOUS SYSTEMS

As could be seen from the previous section, vibrations of strings, rods and shafts are described by the same mathematical model. Therefore, its analysis can be discussed simultaneously. The strict solution can be produced only if parameters of the system considered are constant. In this case the governing equation

$$\frac{\partial^2 y(z, t)}{\partial t^2} - \lambda^2 \frac{\partial^2 y(z, t)}{\partial z^2} = q(z, t) \quad (3.30)$$

is classified as linear partial differential equation of two variables (z and t) with constant coefficients (λ^2). The general solution, a function of two variables, is sum of the general solution of the homogeneous equation and the particular solution of the non-homogeneous equation. If the external excitation $q(z, t) = 0$, the equation 3.30 describes the free vibration of the system due to a non-zero initial excitation determined by the initial conditions.

3.2.1 Free vibration of strings, rods and shafts

The free vibrations (natural vibrations) are governed by the homogeneous equation of Eq. 3.30

$$\frac{\partial^2 y(z, t)}{\partial t^2} - \lambda^2 \frac{\partial^2 y(z, t)}{\partial z^2} = 0 \quad (3.31)$$

Boundary conditions - natural frequencies and natural modes

Let us predict the particular solution of the above equation in a form of the product of two functions. One of them is a function of the position z and the other one is a function of time t .

$$y(z, t) = Y(z) \sin \omega_n t \quad (3.32)$$

Introduction of the predicted solution 3.32 into equation 3.31 yields the following ordinary differential equation

$$-\omega_n^2 Y(z) - \lambda^2 Y''(z) = 0 \quad (3.33)$$

or

$$Y''(z) + \beta_n^2 Y(z) = 0 \quad (3.34)$$

where

$$\beta_n = \frac{\omega_n}{\lambda} \quad (3.35)$$

The general solution of this equation is

$$Y_n(z) = S_n \sin \beta_n z + C_n \cos \beta_n z \quad (3.36)$$



where

$$\beta_n = \omega_n \sqrt{\frac{A\rho}{T}} \quad \text{for strings} \quad (3.37)$$

$$\beta_n = \omega_n \sqrt{\frac{\rho}{E}} \quad \text{for rods} \quad (3.38)$$

$$\beta_n = \omega_n \sqrt{\frac{\rho}{G}} \quad \text{for shafts} \quad (3.39)$$

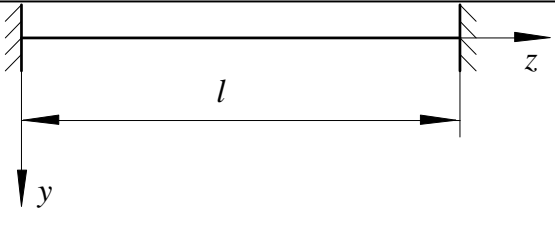
The values for the parameter β_n as well as the constants S_n and C_n should be chosen to fulfill the boundary conditions. Some of the boundary conditions for strings, rods and shafts are shown in the following table.

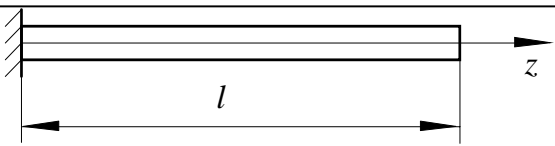
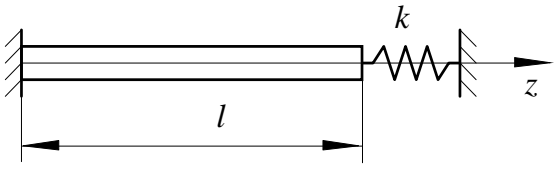
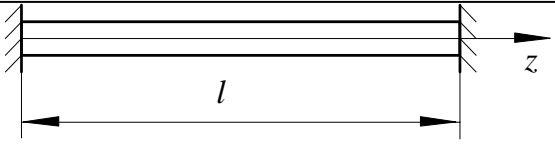
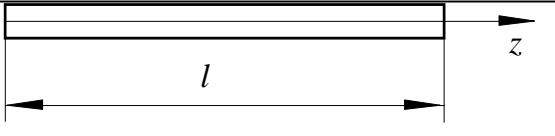
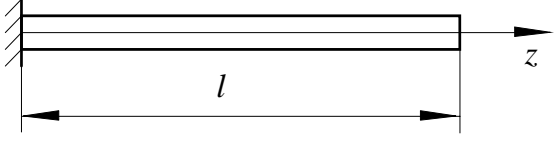
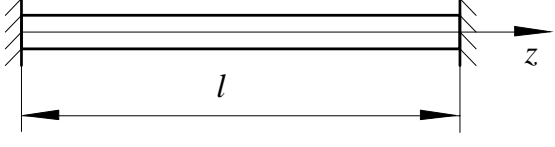
Table 3.1	
 <p style="text-align: center;">string</p>	for $z = 0$ $Y_n = 0$ for $z = l$ $Y_n = 0$
 <p style="text-align: center;">free-free rod</p>	for $z = 0$ $F = AEY_n^I = 0$ for $z = l$ $F = AEY_n^I = 0$
 <p style="text-align: center;">fixed-free rod</p>	for $z = 0$ $Y_n = 0$ for $z = l$ $F = AEY_n^I = 0$
 <p style="text-align: center;">fixed-elastically supported rod</p>	for $z = 0$ $Y_n = 0$ for $z = l$ $F = AEY_n^I = -kY_n$
 <p style="text-align: center;">fixed-fixed rod</p>	for $z = 0$ $Y_n = 0$ for $z = l$ $Y_n = 0$
 <p style="text-align: center;">free-free shaft</p>	for $z = 0$ $T = GJY_n^I = 0$ for $z = l$ $T = GJY_n^I = 0$
 <p style="text-align: center;">fixed free shaft</p>	for $z = 0$ $Y_n = 0$ for $z = l$ $T = GJY_n^I = 0$
 <p style="text-align: center;">fixed-fixed shaft</p>	for $z = 0$ $Y_n = 0$ for $z = l$ $Y_n = 0$

To demonstrate the way of the determination of the natural frequencies and the corresponding natural modes, let us consider the fixed on both ends shaft (last row of the above Table). For this case the boundary conditions are

$$\begin{aligned} \text{for } z &= 0 & Y_n &= 0 \\ \text{for } z &= l & Y_n &= 0 \end{aligned} \quad (3.40)$$

Introduction of this boundary conditions into the solution 3.36, results in a set of two homogeneous algebraic equations linear with respect to the constants S_n and C_n .

$$\begin{aligned} 0 &= 0 \cdot S_n + 1 \cdot C_n \\ 0 &= (\sin \beta_n l) S_n + (\cos \beta_n l) C_n \end{aligned} \quad (3.41)$$

Its matrix form is

$$\begin{bmatrix} 0 & 1 \\ \sin \beta_n l & \cos \beta_n l \end{bmatrix} \begin{bmatrix} S_n \\ C_n \end{bmatrix} = \begin{bmatrix} 0 \\ 0 \end{bmatrix} \quad (3.42)$$

This set of equations has non-zero solutions if and only if its characteristic determinant is equal to zero.

$$\begin{vmatrix} 0 & 1 \\ \sin \beta_n l & \cos \beta_n l \end{vmatrix} = 0 \quad (3.43)$$

Hence, in this particular case we have

$$\sin \beta_n l = 0 \quad (3.44)$$

This equation is called *characteristic equation* and has infinite number of solution. Since β_n and l are always positive, only positive roots of the above equation has the physical meaning

$$\beta_1 = \frac{\pi}{l}, \quad \beta_2 = \frac{2\pi}{l}, \dots, \quad \beta_n = \frac{n\pi}{l}, \dots, \quad n = 1, 2, \dots, \infty \quad (3.45)$$

Taking advantage of equation 3.39 one can compute the natural frequencies to be $\beta_n = \omega_n \sqrt{\frac{\rho}{G}}$

$$\omega_n = \beta_n \sqrt{\frac{G}{\rho}} = \frac{n\pi}{l} \sqrt{\frac{G}{\rho}} \quad n = 1, 2, \dots, \infty \quad (3.46)$$

For each of this natural frequencies the set of equations 3.41 becomes linearly dependant and one of the constants can be chosen arbitrarily. If one choose arbitrarily S_n , say $S_n = 1$, according to the first equation of the set 3.41, C_n has to be equal to 0. Therefore we can conclude that the predicted solution, according to 3.36, in the case considered is

$$Y_n(z) = \sin \beta_n z = \sin \frac{n\pi}{l} z \quad n = 1, 2, \dots, \infty \quad (3.47)$$

The functions $Y_n(z)$ are called *eigenfunctions* or *natural modes* and the corresponding roots ω_n are called *eigenvalues* or *natural frequencies*. The above analysis allows to conclude that a continuous system possesses infinite number of the natural frequencies and infinite number of the corresponding natural modes. The first mode is called *fundamental mode* and the corresponding frequency is called *fundamental natural frequency*. In the case of free vibrations of the shaft, the natural modes determine the angular positions of the cross-section of the shaft $\varphi(z)$. A few first of them are shown in Fig. 5

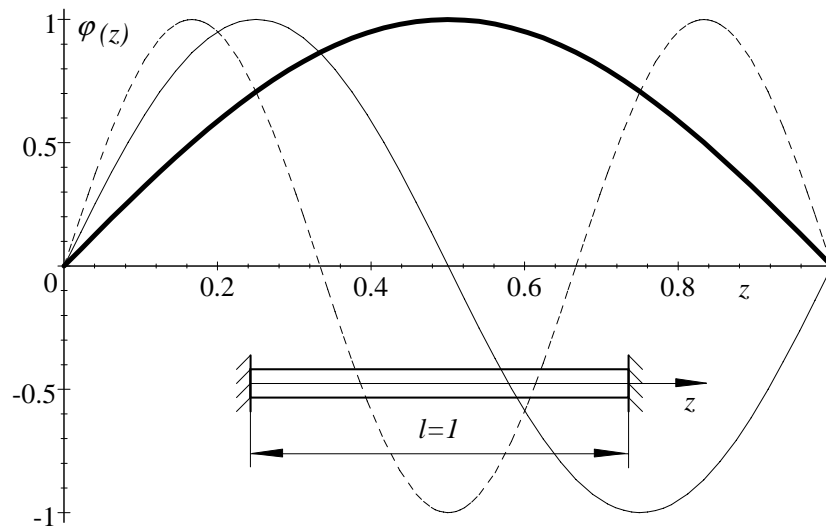

Figure 5

Orthogonality of the natural modes

Let us consider two arbitrarily chosen natural modes $Y_i(z)$ and $Y_j(z)$. Both of them must fulfill the equation 3.33

$$-\omega_n^2 Y(z) - \lambda^2 Y''(z) = 0$$

Hence

$$-\omega_i^2 Y_i(z) - \lambda^2 Y_i''(z) = 0 \quad (3.48)$$

$$-\omega_j^2 Y_j(z) - \lambda^2 Y_j''(z) = 0 \quad (3.49)$$

Premultiplying the equation 3.48 by $Y_j(z)$ and the equation 3.49 by $Y_i(z)$ and then integrating them side by side one can get

$$\begin{aligned} \omega_i^2 \int_0^l Y_i(z) Y_j(z) dz + \lambda^2 \int_0^l Y_i''(z) Y_j(z) dz &= 0 \\ \omega_j^2 \int_0^l Y_j(z) Y_i(z) dz + \lambda^2 \int_0^l Y_j''(z) Y_i(z) dz &= 0 \end{aligned} \quad (3.50)$$

The second integrals can be integrated by parts. Hence

$$\begin{aligned} \omega_i^2 \int_0^l Y_i(z) Y_j(z) dz + \lambda^2 \left(Y_i'(z) Y_j(z) \Big|_0^l \right) - \lambda^2 \int_0^l Y_i'(z) Y_j'(z) dz &= 0 \\ \omega_j^2 \int_0^l Y_j(z) Y_i(z) dz + \lambda^2 \left(Y_j'(z) Y_i(z) \Big|_0^l \right) - \lambda^2 \int_0^l Y_i'(z) Y_j'(z) dz &= 0 \end{aligned} \quad (3.51)$$

Substraction of the second equation from the first one yields

$$(\omega_i^2 - \omega_j^2) \int_0^l Y_j(z) Y_i(z) dz + \lambda^2 \left((Y_i'(z) Y_j(z)) \Big|_0^l - (Y_j'(z) Y_i(z)) \Big|_0^l \right) = 0 \quad (3.52)$$

It is easy to show that for any boundary conditions the second expression is equal to zero

$$(Y_i^I(z)Y_j(z))\Big|_0^l - (Y_j^I(z)Y_i(z))\Big|_0^l = Y_i^I(l)Y_j(l) - Y_i^I(0)Y_j(0) - Y_j^I(l)Y_i(l) + Y_j^I(0)Y_i(0) = 0 \quad (3.53)$$

Hence,

$$\int_0^l Y_j(z)Y_i(z)dz = 0 \quad (3.54)$$

The above property of the eigenfunctions is called *orthogonality condition*.

General solution of the homogeneous equation

According to 3.32 one of the particular solution of the equation 3.31 can be adopted in the following form

$$y(z, t) = Y(z) \sin \omega_n t \quad (3.55)$$

At this stage of consideration the function $Y(z)$ is known and we are able to produce infinite number of such particular solutions.

$$y_n(z, t) = Y_n(z) \sin \omega_n t \quad n = 1, 2, 3, \dots, \infty \quad (3.56)$$

Since the equation 3.31 is of second order with respect to time, to fulfill initial conditions we need second set of linearly independent solution. In the same manner as it was done in the previous section one may prove that the following functions form the required linearly independent set of solution.

$$y_n(z, t) = Y_n(z) \cos \omega_n t \quad n = 1, 2, 3, \dots, \infty \quad (3.57)$$

Hence, the general solution of the equation 3.31 eventually may be adopted in the following form.

$$y(z, t) = \sum_{n=1}^{\infty} S_n Y_n(z) \sin \omega_n t + C_n Y_n(z) \cos \omega_n t \quad (3.58)$$

This solution has to fulfill the initial conditions. The initial conditions determine the *initial position* $Y_0(z)$ and the *initial velocity* $V_0(z)$ of the system considered for the time t equal to zero.

$$y(z, 0) = Y_0(z) \quad \frac{\partial}{\partial t} y(z, 0) = V_0(z) \quad (3.59)$$

To produce the constant S_n and C_n let us introduce the solution 3.58 into the above initial conditions. This operation results in the following two equations.

$$\begin{aligned} Y_0(z) &= \sum_{n=1}^{\infty} C_n Y_n(z) \\ V_0(z) &= \sum_{n=1}^{\infty} S_n \omega_n Y_n(z) \end{aligned} \quad (3.60)$$

To determine the unknown constants S_n and C_n , let us multiply the above equations by $Y_m(z)$ and then integrate them side by side

$$\begin{aligned}\int_0^l Y_0(z)Y_m(z)dz &= \sum_{n=1}^{\infty} C_n \int_0^l Y_n(z)Y_m(z)dz \\ \int_0^l V_0(z)Y_m(z)dz &= \sum_{n=1}^{\infty} S_n \omega_n \int_0^l Y_n(z)Y_m(z)dz\end{aligned}\quad (3.61)$$

Taking advantage of the developed orthogonality conditions 3.54 the wanted constants S_n and C_n are

$$\begin{aligned}C_n &= \frac{\int_0^l Y_0(z)Y_n(z)dz}{\int_0^l Y_n^2(z)dz} \\ S_n &= \frac{1}{\omega_n} \frac{\int_0^l V_0(z)Y_n(z)dz}{\int_0^l Y_n^2(z)dz}\end{aligned}\quad (3.62)$$

For the example considered in the previous section the above formulae, according to 3.47, take form

$$\begin{aligned}C_n &= \frac{\int_0^l Y_0(z) \sin \frac{n\pi}{l} z dz}{\int_0^l (\sin \frac{n\pi}{l} z)^2 dz} \\ S_n &= \frac{1}{\omega_n} \frac{\int_0^l V_0(z) \sin \frac{n\pi}{l} z dz}{\int_0^l (\sin \frac{n\pi}{l} z)^2 dz}\end{aligned}\quad (3.63)$$

3.2.2 Free vibrations of beams

For the uniform beam the equation of motion was derived to be

$$\frac{\partial^2 y(z, t)}{\partial t^2} + \lambda^2 \frac{\partial^4 y(z, t)}{\partial z^4} = q(z, t)\quad (3.64)$$

This equation can be classified as linear partial differential equation of two variables (z and t) with constant coefficients (λ^2). Its order with respect to time is 2 and with respect to z is equal to 4. The general solution, a function of two variables, is sum of the general solution of the homogeneous equation and the particular solution of the non-homogeneous equation. If the external excitation $q(z, t) = 0$, the equation 3.64 describes the free vibration of the beam due to a non-zero initial conditions.

The free vibrations (natural vibrations) are governed by the homogeneous equation of 3.64.

$$\frac{\partial^2 y(z, t)}{\partial t^2} + \lambda^2 \frac{\partial^4 y(z, t)}{\partial z^4} = 0\quad (3.65)$$

Boundary conditions - natural frequencies and natural modes

Similarly to the analysis of strings and shafts, let us predict the solution of the above equation in the form of a product of two functions. One of them is a function of the position z and the other is the function of time t .

$$y(z, t) = Y(z) \sin \omega_n t\quad (3.66)$$

Introduction of the predicted solution 3.66 into equation 3.65 yields the following ordinary differential equation

$$-\omega_n^2 Y(z) + \lambda^2 Y^{IV}(z) = 0 \quad (3.67)$$

or

$$Y^{IV}(z) - \beta_n^4 Y(z) = 0 \quad (3.68)$$

where

$$\beta_n^4 = \frac{\omega_n^2}{\lambda^2} = \frac{A\rho}{EJ} \omega_n^2 \quad (3.69)$$

The standard form of its particular solution is

$$Y(z) = e^{rz} \quad (3.70)$$

Introduction of this solution into the equation 3.68 yields the characteristic equation

$$r^4 = \beta_n^4 \quad (3.71)$$

Its roots

$$r_1 = \beta_n \quad r_2 = -\beta_n \quad r_3 = i\beta_n \quad r_4 = -i\beta_n \quad (3.72)$$

determine the set of the linearly independent particular solution.

$$Y_1(z) = e^{\beta_n z} \quad Y_2(z) = e^{-\beta_n z} \quad Y_3(z) = e^{i\beta_n z} \quad Y_4(z) = e^{-i\beta_n z} \quad (3.73)$$

Alternatively, one can choose their combinations as the set of the independent solutions

$$\begin{aligned} Y_1(z) &= \frac{e^{\beta_n z} - e^{-\beta_n z}}{2} = \sinh \beta_n z & Y_2(z) &= \frac{e^{\beta_n z} + e^{-\beta_n z}}{2} = \cosh \beta_n z \\ Y_3(z) &= \frac{e^{i\beta_n z} - e^{-i\beta_n z}}{2} = \sin \beta_n z & Y_4(z) &= \frac{e^{i\beta_n z} + e^{-i\beta_n z}}{2} = \cos \beta_n z \end{aligned} \quad (3.74)$$

A graphical interpretation of these functions for $\beta_n = 1$ is given in Fig. 6.

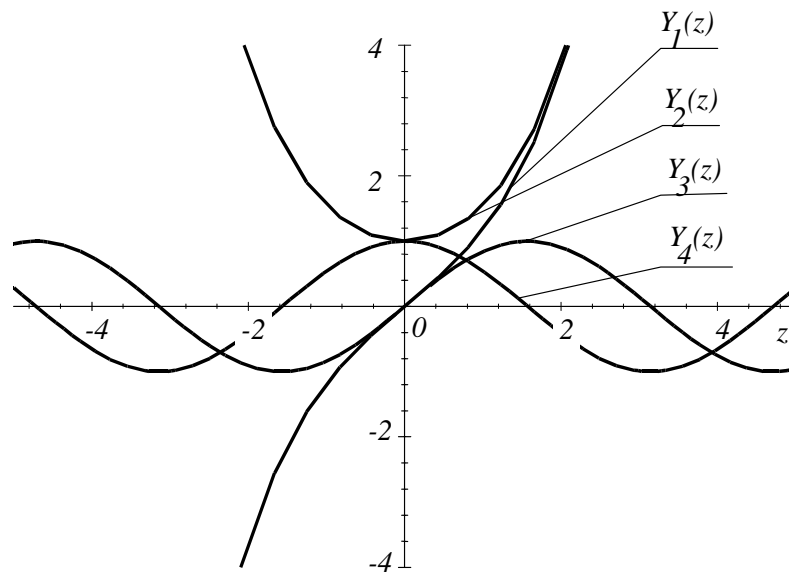

Figure 6

The general solution of the equation 3.68, as a linear combination of these particular solutions is

$$Y_n(z) = A_n \sinh \beta_n z + B_n \cosh \beta_n z + C_n \sin \beta_n z + D_n \cos \beta_n z \tag{3.75}$$

Values for the parameter β_n as well as for the constants A_n, B_n, C_n and D_n should be chosen to fulfill boundary conditions. Since this equation is of fourth order, one has to produce four boundary conditions reflecting the conditions at both ends of the beam. They involve the function $Y(z)$ and its first three derivatives with respect to z .

$$Y_n(z) = A_n \sinh \beta_n z + B_n \cosh \beta_n z + C_n \sin \beta_n z + D_n \cos \beta_n z \tag{3.76}$$

$$Y_n^I(z) = A_n \beta_n \cosh \beta_n z + B_n \beta_n \sinh \beta_n z + C_n \beta_n \cos \beta_n z - D_n \beta_n \sin \beta_n z \tag{3.77}$$

$$Y_n^{II}(z) = A_n \beta_n^2 \sinh \beta_n z + B_n \beta_n^2 \cosh \beta_n z - C_n \beta_n^2 \sin \beta_n z - D_n \beta_n^2 \cos \beta_n z \tag{3.78}$$

$$Y_n^I(z) = A_n \beta_n^3 \cosh \beta_n z + B_n \beta_n^3 \sinh \beta_n z - C_n \beta_n^3 \cos \beta_n z - D_n \beta_n^3 \sin \beta_n z \tag{3.79}$$

The boundary conditions for some cases of beams are shown in Table 3.2.

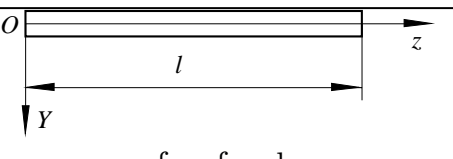
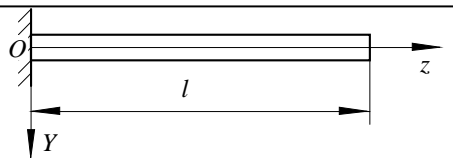
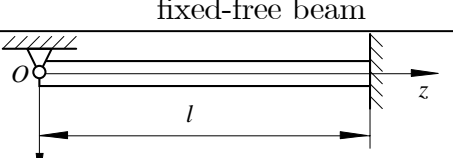
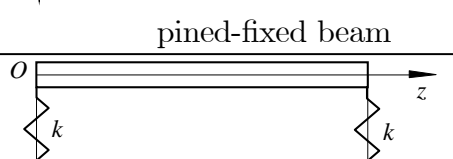
Table 3.2	
 <p style="text-align: center;">free-free beam</p>	for $z = 0$ $M(0) = EJY^{II}(0) = 0$ for $z = 0$ $V(0) = EJY^{III}(0) = 0$ for $z = l$ $M(l) = EJY^{II}(l) = 0$ for $z = l$ $V(l) = EJY^{III}(l) = 0$
 <p style="text-align: center;">fixed-free beam</p>	for $z = 0$ $Y(0) = 0$ for $z = 0$ $Y^I(0) = 0$ for $z = l$ $M(l) = EJY^{II}(l) = 0$ for $z = l$ $V(l) = EJY^{III}(l) = 0$
 <p style="text-align: center;">pined-fixed beam</p>	for $z = 0$ $Y(0) = 0$ for $z = 0$ $M(0) = EJY^{II}(0) = 0$ for $z = l$ $Y(l) = 0$ for $z = l$ $Y^I(l) = 0$
 <p style="text-align: center;">elastically supported beam</p>	for $z = 0$ $M(0) = EJY^{II}(0) = 0$ for $z = 0$ $V(0) = EJY^{III}(0) = -kY(0)$ for $z = l$ $M(l) = EJY^{II}(l) = 0$ for $z = l$ $V(l) = EJY^{III}(l) = +kY(l)$

Let us take advantage of the boundary conditions corresponding to the free-free beam in order to determine the natural frequencies and the natural modes.

$$\begin{aligned} \text{for } z = 0 \quad M(0) &= EJY''(0) = 0 \\ \text{for } z = 0 \quad V(0) &= EJY'''(0) = 0 \\ \text{for } z = l \quad M(l) &= EJY''(l) = 0 \\ \text{for } z = l \quad V(l) &= EJY'''(l) = 0 \end{aligned} \quad (3.80)$$

Introduction of the functions 3.78 and 3.79 into the above boundary conditions results in the following set of algebraic equations that are linear with respect to the constants A_n , B_n , C_n and D_n .

$$\begin{bmatrix} 0 & \beta_n^2 & 0 & -\beta_n^2 \\ \beta_n^3 & 0 & -\beta_n^3 & 0 \\ \beta_n^2 \sinh \beta_n l & \beta_n^2 \cosh \beta_n l & -\beta_n^2 \sin \beta_n l & -\beta_n^2 \cos \beta_n l \\ \beta_n^3 \cosh \beta_n l & \beta_n^3 \sinh \beta_n l & -\beta_n^3 \cos \beta_n l & \beta_n^3 \sin \beta_n l \end{bmatrix} \begin{bmatrix} A_n \\ B_n \\ C_n \\ D_n \end{bmatrix} = \begin{bmatrix} 0 \\ 0 \\ 0 \\ 0 \end{bmatrix} \quad (3.81)$$

They have a non-zero solution if and only if their characteristic determinant is equal to zero. This condition forms the characteristic equation

$$\begin{vmatrix} 0 & 1 & 0 & -1 \\ 1 & 0 & -1 & 0 \\ \sinh \beta_n l & \cosh \beta_n l & -\sin \beta_n l & -\cos \beta_n l \\ \cosh \beta_n l & \sinh \beta_n l & -\cos \beta_n l & \sin \beta_n l \end{vmatrix} = 0 \quad (3.82)$$

that, after simplification, takes the following form

$$\cosh \beta_n l \cos \beta_n l - 1 = 0 \quad (3.83)$$

This characteristic equation is transcendental and therefore has infinite number of roots. Solution of this equation, within a limited range of the parameter $\beta_n l$ is shown in Fig. 7

The first few roots are

$$\beta_0 l = 0 \quad \beta_1 l = 4.73 \quad \beta_2 l = 7.85 \quad \beta_3 l = 11 \dots \dots \dots \quad (3.84)$$

As one can see from the diagram 7, the characteristic equation has double root of zero magnitude. Since the beam considered is free-free in space, this root is associated with the possible translation and rotation of the beam as a rigid body. These two modes, corresponding to the zero root are shown in Fig. 8a) and b). Modes corresponding to the non-zero roots can be produced according to the following procedure.

For any root of the characteristic equation the set of equations 3.81, since its characteristic determinant is zero, becomes linearly dependant. Therefore, it is possible to choose arbitrarily one of the constants (for example A_n) and the other can be obtained from three arbitrarily chosen equations 3.81. If we take advantage of the second, third and fourth equation we are getting

$$\begin{bmatrix} 0 & -1 & 0 \\ \cosh \beta_n l & -\sin \beta_n l & -\cos \beta_n l \\ \sinh \beta_n l & -\cos \beta_n l & \sin \beta_n l \end{bmatrix} \begin{bmatrix} B_n \\ C_n \\ D_n \end{bmatrix} = - \begin{bmatrix} 1 \\ \sinh \beta_n l \\ \cosh \beta_n l \end{bmatrix} A_n \quad (3.85)$$

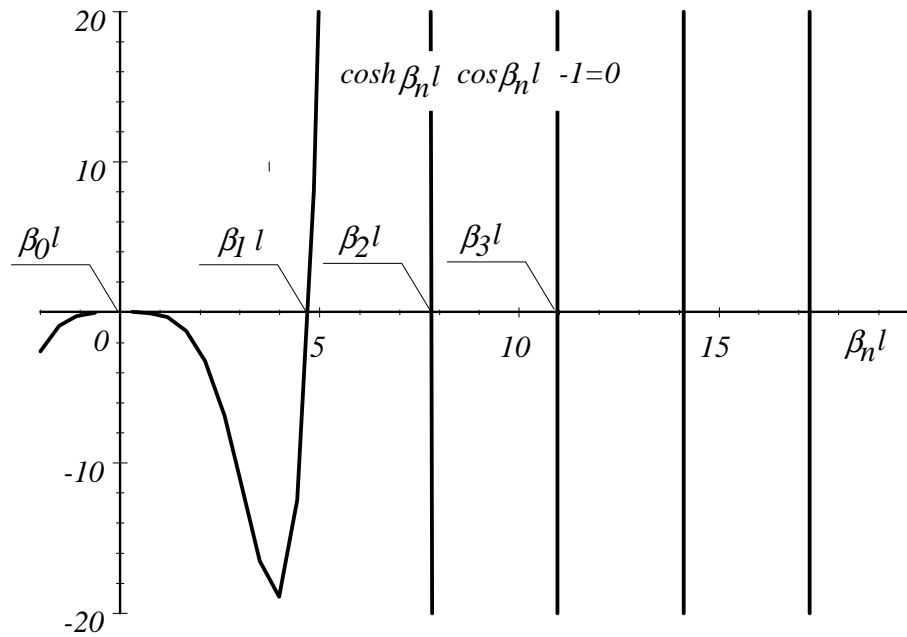

Figure 7

Hence, for $A_n = -1$ we have

$$\begin{bmatrix} B_n \\ C_n \\ D_n \end{bmatrix} = \begin{bmatrix} 0 & -1 & 0 \\ \cosh \beta_n l & -\sin \beta_n l & -\cos \beta_n l \\ \sinh \beta_n l & -\cos \beta_n l & \sin \beta_n l \end{bmatrix}^{-1} \begin{bmatrix} 1 \\ \sinh \beta_n l \\ \cosh \beta_n l \end{bmatrix} \quad (3.86)$$

For the first non-zero root $\beta_1 l = 4.73$ the above set of equations yields values for constants B_1 , C_1 and D_1

$$\begin{bmatrix} B_1 \\ C_1 \\ D_1 \end{bmatrix} = \begin{bmatrix} 0 & -1 & 0 \\ \cosh 4.73 & -\sin 4.73 & -\cos 4.73 \\ \sinh 4.73 & -\cos 4.73 & \sin 4.73 \end{bmatrix}^{-1} \begin{bmatrix} 1 \\ \sinh 4.73 \\ \cosh 4.73 \end{bmatrix} = \begin{bmatrix} 1.0178 \\ -1.0 \\ 1.0177 \end{bmatrix} \quad (3.87)$$

Hence, the corresponding mode, according to Eq. 3.75 is

$$Y_1(z) = -1.0 \sinh 4.73z + 1.0178 \cosh 4.73z - 1.0 \sin 4.73z + 1.0177 \cos 4.73z \quad (3.88)$$

Its graphical representation is shown in Fig. 8c).

In the same manner one can produce modes for all the other characteristic roots. Modes for $\beta_2 l = 7.85$ and $\beta_3 l = 11$ are shown in Fig. 8d) and e) respectively. The formula 3.69 allows the natural frequencies to be computed.

$$\omega_n = \beta_n^2 \sqrt{\frac{EJ}{A\rho}} = \frac{(\beta_n l)^2}{l^2} \sqrt{\frac{EJ}{A\rho}} \quad (3.89)$$

Eventually, taking into account the predicted solution 3.66, the particular solution is

$$y(z, t) = S_n Y_n(z) \sin \omega_n t \quad (3.90)$$

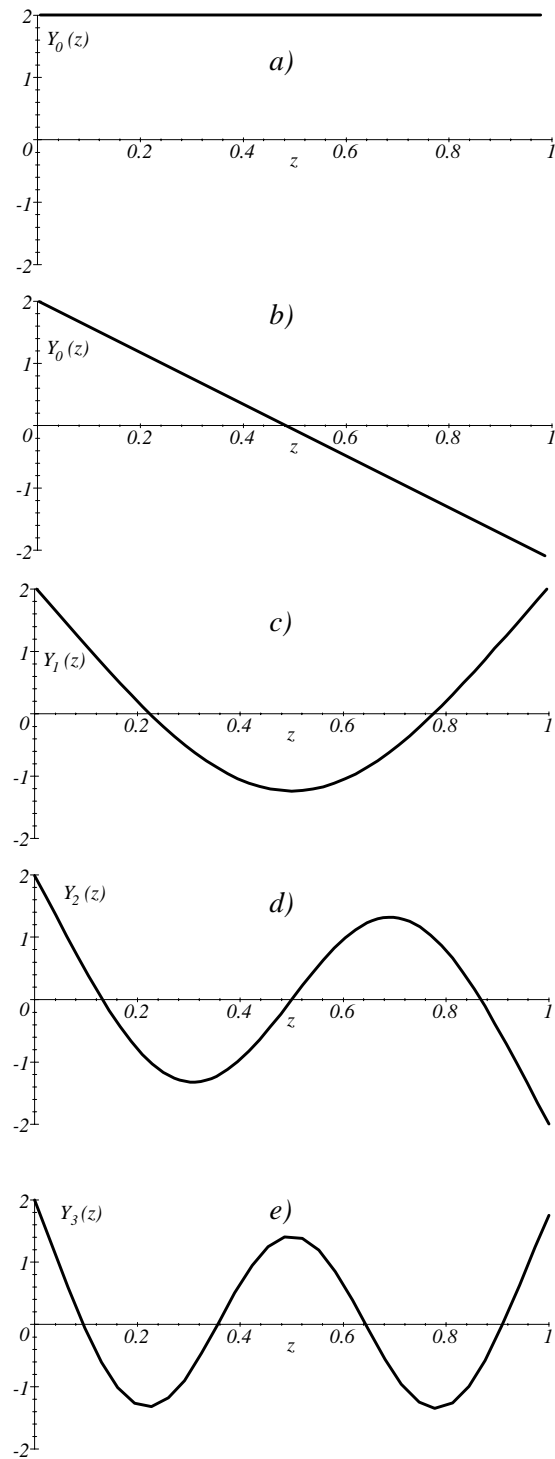

Figure 8

where $Y_n(z)$ and ω_n are uniquely determined and S_n is an arbitrarily chosen constant.

In the same manner we can show that the function

$$y(z, t) = C_n Y_n(z) \cos \omega_n t \quad (3.91)$$

is the linearly independent particular solution too. It follows that the following linear combination

$$\sum_{n=1}^{n=\infty} Y_n(z) (S_n \sin \omega_n t + C_n \cos \omega_n t) \quad (3.92)$$

where

$$\begin{aligned} Y_1(z) &= -1.0 \sinh 4.73z + 1.0178 \cosh 4.73z - 1.0 \sin 4.73z + 1.0177 \cos 4.73z \\ Y_2(z) &= \dots\dots\dots \\ &\dots\dots\dots \end{aligned} \quad (3.93)$$

is the general solution of the equation 3.65. The constants S_n and C_n should be chosen to fulfill the initial conditions.

Orthogonality of the natural modes Let us consider two arbitrarily chosen natural modes $Y_i(z)$ and $Y_j(z)$. Both of them must fulfill the equation 3.67

$$-\omega_n^2 Y(z) + \lambda^2 Y^{IV}(z) = 0$$

Hence

$$-\omega_i^2 Y_i(z) + \lambda^2 Y_i^{IV}(z) = 0 \quad (3.94)$$

$$-\omega_j^2 Y_j(z) + \lambda^2 Y_j^{IV}(z) = 0 \quad (3.95)$$

Premultiplying the equation 3.94 by $Y_j(z)$ and the equation 3.95 by $Y_i(z)$ and then integrating them side by side one can get

$$\begin{aligned} -\omega_i^2 \int_0^l Y_i(z) Y_j(z) dz + \lambda^2 \int_0^l Y_i^{IV}(z) Y_j(z) dz &= 0 \\ -\omega_j^2 \int_0^l Y_j(z) Y_i(z) dz + \lambda^2 \int_0^l Y_j^{IV}(z) Y_i(z) dz &= 0 \end{aligned} \quad (3.96)$$

The second integrals can be integrated by parts. Hence

$$\begin{aligned} -\omega_i^2 \int_0^l Y_i(z) Y_j(z) dz + \lambda^2 \left(Y_i^{III}(z) Y_j(z) \Big|_0^l \right) - \lambda^2 \int_0^l Y_i^{III}(z) Y_j^I(z) dz &= 0 \\ -\omega_j^2 \int_0^l Y_j(z) Y_i(z) dz + \lambda^2 \left(Y_j^{III}(z) Y_i(z) \Big|_0^l \right) - \lambda^2 \int_0^l Y_j^{III}(z) Y_i^I(z) dz &= 0 \end{aligned} \quad (3.97)$$

*3.2.3 Problems***Problem 41**

Figure 9

For the shaft shown in Fig. 9 produce equation for its natural frequencies.

Solution

For

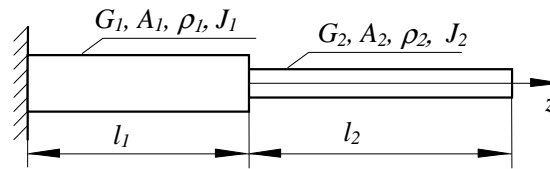
$$0 < z < l_1 \quad (3.102)$$

motion of the system, according to 3.19, is governed by the following equation

$$\frac{\partial^2 \varphi_1(z, t)}{\partial t^2} - \lambda_1^2 \frac{\partial^2 \varphi_1(z, t)}{\partial z^2} = 0 \quad (3.103)$$

where

$$\lambda_1^2 = \frac{G_1}{\rho_1} \quad (3.104)$$

Similarly, one may say that within range

$$l_1 < z < l_1 + l_2 \quad (3.105)$$

motion of the shaft is governed by

$$\frac{\partial^2 \varphi_2(z, t)}{\partial t^2} - \lambda_2^2 \frac{\partial^2 \varphi_2(z, t)}{\partial z^2} = 0 \quad (3.106)$$

where

$$\lambda_2^2 = \frac{G_2}{\rho_2} \quad (3.107)$$

Both parts of the shaft must have the same natural frequencies. Therefore the particular solution of the above equations must be of the following form

$$\varphi_1(z, t) = \Phi_1(z) \sin \omega_n t \quad (3.108)$$

$$\varphi_2(z, t) = \Phi_2(z) \sin \omega_n t \quad (3.109)$$

Introduction of these solutions into the equations of motion yields, according to 3.34,

$$\Phi_1^{II}(z) + \beta_{n1}^2 \Phi_1(z) = 0 \quad (3.110)$$

$$\Phi_2^{II}(z) + \beta_{n2}^2 \Phi_2(z) = 0 \quad (3.111)$$

where

$$\beta_{n1} = \frac{\omega_n}{\lambda_1} \quad \beta_{n2} = \frac{\omega_n}{\lambda_2} \quad (3.112)$$

These two equations are coupled together by the following boundary conditions

$$\begin{aligned} \text{for } z &= 0 & \Phi_1(0) &= 0 \\ \text{for } z &= l_1 & \Phi_1(l_1) &= \Phi_2(l_1) \\ \text{for } z &= l_1 & G_1 J_1 \Phi_1^I(l_1) &= G_2 J_2 \Phi_2^I(l_1) \\ \text{for } z &= l_1 + l_2 & \Phi_2^I(l_1 + l_2) &= 0 \end{aligned} \quad (3.113)$$

The first boundary condition reflects the fact that the left hand end of the shaft is fixed. The second and the third condition represent the continuity of the angular

displacement and continuity of the torque. The last condition says that the torque at the free end is zero. Since the general solution of equation 3.110 and 3.111 are

$$\Phi_1(z) = S_{n1} \sin \frac{\omega_n}{\lambda_1} z + C_{n1} \cos \frac{\omega_n}{\lambda_1} z \quad (3.114)$$

$$\Phi_2(z) = S_{n2} \sin \frac{\omega_n}{\lambda_2} z + C_{n2} \cos \frac{\omega_n}{\lambda_2} z \quad (3.115)$$

the formulated boundary conditions results in the following set of equations

$$\begin{aligned} C_{n1} &= 0 \\ S_{n1} \sin \frac{\omega_n}{\lambda_1} l_1 + C_{n1} \cos \frac{\omega_n}{\lambda_1} l_1 - S_{n2} \sin \frac{\omega_n}{\lambda_2} l_2 - C_{n2} \cos \frac{\omega_n}{\lambda_2} l_2 &= 0 \\ S_{n1} G_1 J_1 \frac{\omega_n}{\lambda_1} \cos \frac{\omega_n}{\lambda_1} l_1 - C_{n1} G_1 J_1 \frac{\omega_n}{\lambda_1} \sin \frac{\omega_n}{\lambda_1} l_1 + \\ &\quad - S_{n2} G_2 J_2 \frac{\omega_n}{\lambda_2} \cos \frac{\omega_n}{\lambda_2} l_1 + C_{n2} G_2 J_2 \frac{\omega_n}{\lambda_2} \sin \frac{\omega_n}{\lambda_2} l_1 = 0 \\ + S_{n2} \frac{\omega_n}{\lambda_2} \cos \frac{\omega_n}{\lambda_2} (l_1 + l_2) - C_{n2} \frac{\omega_n}{\lambda_2} \sin \frac{\omega_n}{\lambda_2} (l_1 + l_2) &= 0 \end{aligned} \quad (3.116)$$

Its matrix for is

$$[A] \begin{bmatrix} S_{n1} \\ C_{n1} \\ S_{n2} \\ C_{n2} \end{bmatrix} = 0 \quad (3.117)$$

where

$$[A] = \begin{bmatrix} 0 & 1 & 0 & 0 \\ \sin \frac{\omega_n}{\lambda_1} l_1 & \cos \frac{\omega_n}{\lambda_1} l_1 & -\sin \frac{\omega_n}{\lambda_2} l_2 & -\cos \frac{\omega_n}{\lambda_2} l_2 \\ G_1 J_1 \frac{\omega_n}{\lambda_1} \cos \frac{\omega_n}{\lambda_1} l_1 & -G_1 J_1 \frac{\omega_n}{\lambda_1} \sin \frac{\omega_n}{\lambda_1} l_1 & -G_2 J_2 \frac{\omega_n}{\lambda_2} \cos \frac{\omega_n}{\lambda_2} l_1 & G_2 J_2 \frac{\omega_n}{\lambda_2} \sin \frac{\omega_n}{\lambda_2} l_1 \\ 0 & 0 & \frac{\omega_n}{\lambda_2} \cos \frac{\omega_n}{\lambda_2} (l_1 + l_2) & -\frac{\omega_n}{\lambda_2} \sin \frac{\omega_n}{\lambda_2} (l_1 + l_2) \end{bmatrix}$$

This homogeneous set of equations has the non-zero solutions if and only if its characteristic determinant is equal to zero.

$$\begin{vmatrix} 0 & 1 & 0 & 0 \\ \sin \frac{\omega_n}{\lambda_1} l_1 & \cos \frac{\omega_n}{\lambda_1} l_1 & -\sin \frac{\omega_n}{\lambda_2} l_2 & -\cos \frac{\omega_n}{\lambda_2} l_2 \\ G_1 J_1 \frac{\omega_n}{\lambda_1} \cos \frac{\omega_n}{\lambda_1} l_1 & -G_1 J_1 \frac{\omega_n}{\lambda_1} \sin \frac{\omega_n}{\lambda_1} l_1 & -G_2 J_2 \frac{\omega_n}{\lambda_2} \cos \frac{\omega_n}{\lambda_2} l_1 & G_2 J_2 \frac{\omega_n}{\lambda_2} \sin \frac{\omega_n}{\lambda_2} l_1 \\ 0 & 0 & \frac{\omega_n}{\lambda_2} \cos \frac{\omega_n}{\lambda_2} (l_1 + l_2) & -\frac{\omega_n}{\lambda_2} \sin \frac{\omega_n}{\lambda_2} (l_1 + l_2) \end{vmatrix} = 0 \quad (3.118)$$

Solution of this equation for the roots ω_n yields the wanted natural frequencies of the shaft.

Problem 42

Figure 10

The uniform rod 1 , shown in Fig. 10, is connected to the block 2 of mass m . Compute the natural frequencies and the corresponding natural modes of this assembly.

Solution

The equation of motion of the rod, according to Eq. 3.12, is

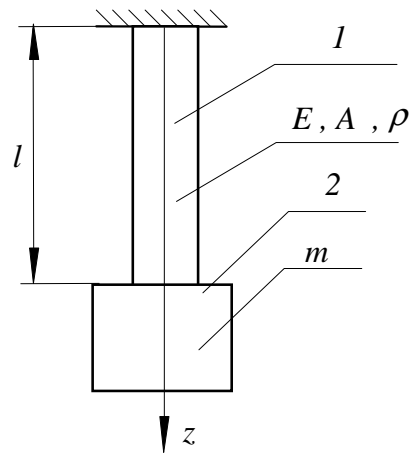
$$\frac{\partial^2 y(z, t)}{\partial t^2} - \lambda^2 \frac{\partial^2 y(z, t)}{\partial z^2} = 0 \quad (3.119)$$

where

$$\lambda^2 = \frac{E}{\rho} \quad (3.120)$$

To produce the boundary conditions let us consider the block 2 with the adjusted infinitesimal element (see Fig. 11).

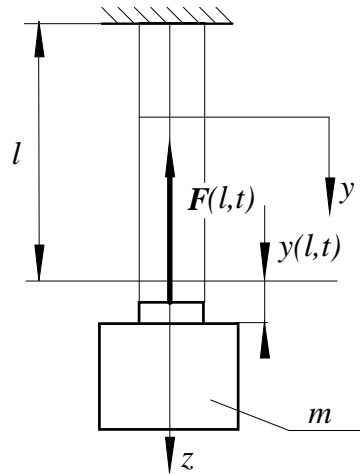

Figure 11

Equation of motion of the block, according to the Newton's law, is

$$m \frac{\partial^2 y(l, t)}{\partial t^2} = -F(l, t) \quad (3.121)$$

or, taking advantage of the relationship 3.8

$$m \left. \frac{\partial^2 y(z, t)}{\partial t^2} \right|_{z=l} = -AE \left. \frac{\partial y(z, t)}{\partial z} \right|_{z=l} \quad (3.122)$$

This equation together with the condition corresponding to the upper end of the rod

$$y(0, t) = 0 \quad (3.123)$$

forms boundary conditions for the equation 3.119.

$$\begin{cases} y(0, t) = 0 \\ m \left. \frac{\partial^2 y(z, t)}{\partial t^2} \right|_{z=l} = -AE \left. \frac{\partial y(z, t)}{\partial z} \right|_{z=l} \end{cases} \quad (3.124)$$

Introduction of the particular solution (see Eq. 3.32)

$$y(z, t) = Y(z) \sin \omega_n t \quad (3.125)$$

into the equation of motion 3.119 and the boundary conditions 3.124 yields the ordinary differential equation

$$Y''(z) + \beta_n^2 Y(z) = 0; \quad \beta_n = \frac{\omega_n}{\lambda} \quad (3.126)$$

with boundary conditions

$$\begin{cases} Y(0) = 0 \\ m\omega_n^2 Y(l) - AEY'(l) = 0 \end{cases} \quad (3.127)$$

The general solution of the equation 3.126, according to 3.36, is

$$Y_n(z) = S_n \sin \beta_n z + C_n \cos \beta_n z \quad (3.128)$$

Introduction of this solution into boundary conditions yields

$$\begin{cases} C_n = 0 \\ m\omega_n^2 (S_n \sin \beta_n z + C_n \cos \beta_n z) - AE (S_n \beta_n \cos \beta_n z - C_n \beta_n \sin \beta_n z) = 0 \end{cases} \quad (3.129)$$

or

$$(m\omega_n^2 \sin \beta_n z - AE\beta_n \cos \beta_n z) S_n = 0 \quad (3.130)$$

Hence, the characteristic equation, after taking advantage of 3.126, is

$$m\omega_n^2 \sin \frac{\omega_n}{\lambda} z - AE \frac{\omega_n}{\lambda} \cos \frac{\omega_n}{\lambda} z = 0 \quad (3.131)$$

or after simplification

$$\tan \frac{\omega_n}{\lambda} l - \frac{AE}{\lambda \omega_n m} = 0 \quad (3.132)$$

For the following numerical data

$$l = 1m$$

$$E = 2.1 \times 10^{11} N/m^2$$

$$A = 25 \times 10^{-4} m^2$$

$$\rho = 7800 kg/m^3$$

$$\lambda = \sqrt{\frac{E}{\rho}} = 5188.7 m/s$$

$$m_r = A \times l \times \rho = 19.5 kg - \text{mass of the rod}$$

$$m = 20 kg - \text{mass of the block}$$

the characteristic equation takes the following form

$$f(\omega_n) = \tan \left(\frac{\omega_n}{5188.7} \right) - \frac{5059.0}{\omega_n} = 0 \quad (3.133)$$

Its solution $f(\omega = 0)$ is shown in Fig. 12.

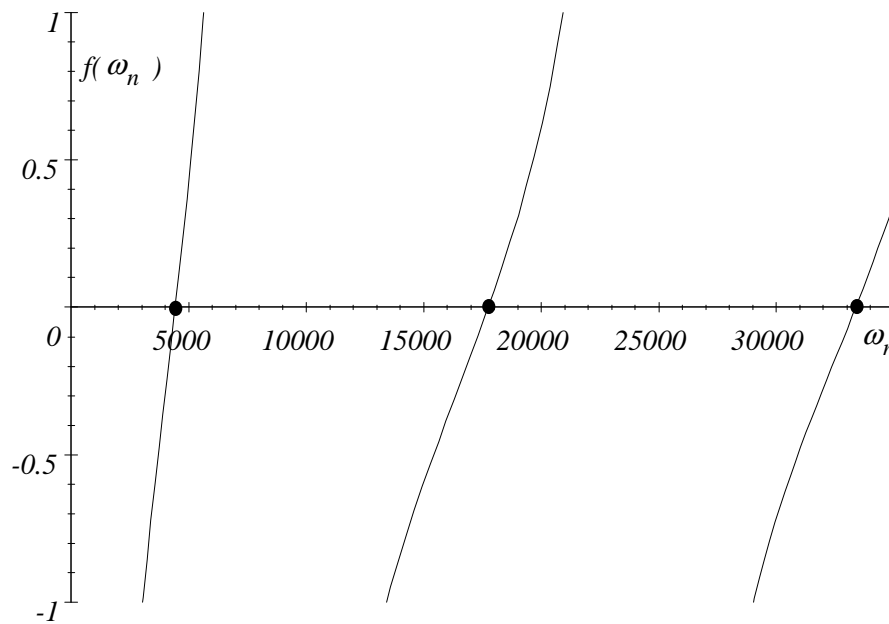

Figure 12

The first three natural frequencies, according to the diagram 12 are

$$\omega_1 = 4400, \quad \omega_2 = 17720, \quad \omega_3 = 33400 \text{ s}^{-1} \quad (3.134)$$

The corresponding natural modes, according to 3.128, are

$$Y_n(z) = S_n \sin \beta_n z = S_n \sin \frac{\omega_n}{\lambda} z = S_n \sin \frac{\omega_n}{5188.7} z \quad (3.135)$$

For the first three natural frequencies the corresponding natural modes

$$Y_1(z) = \sin \frac{4400}{5188.7} z \quad Y_2(z) = \sin \frac{17720}{5188.7} z \quad Y_3(z) = \sin \frac{33400}{5188.7} z \quad (3.136)$$

are presented in Fig. 13, 14 and 15 respectively. If we neglect the mass of the rod, the system becomes of one degree of freedom and its the only one natural frequency is

$$\omega_1 = \sqrt{\frac{k}{m}} = \sqrt{\frac{EA}{lm}} = \sqrt{\frac{2.1 \times 10^{11} \times 25 \times 10^{-4}}{20}} = 5123 \text{ s}^{-1} \quad (3.137)$$

and the corresponding mode is a straight line.

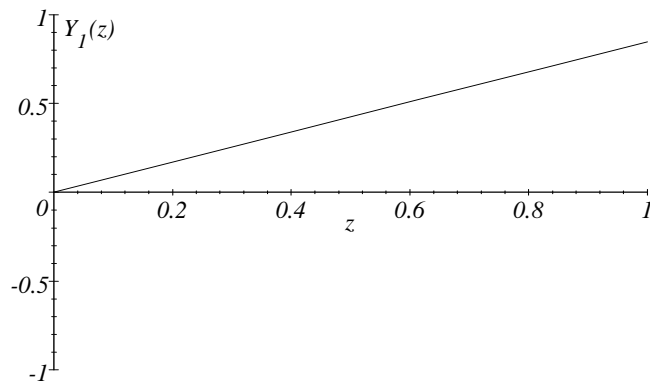

Figure 13

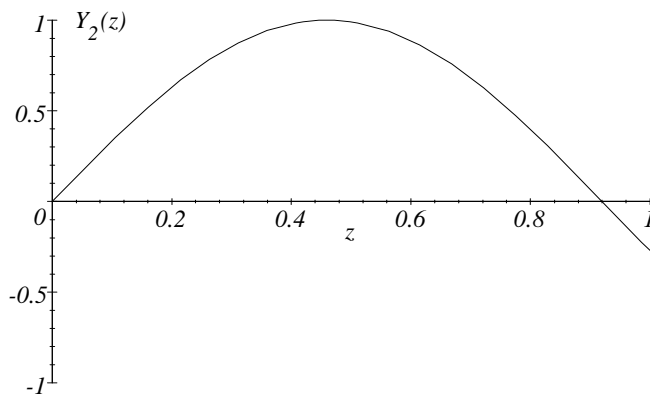

Figure 14

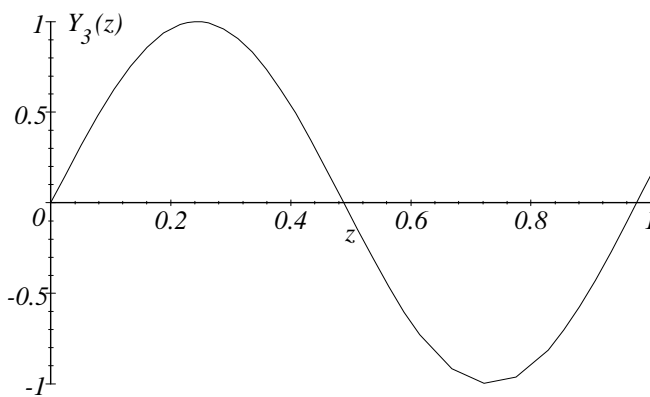

Figure 15

Problem 43

Produce natural frequencies and the corresponding natural modes for the fixed-
elastically supported beam shown in Fig. 16

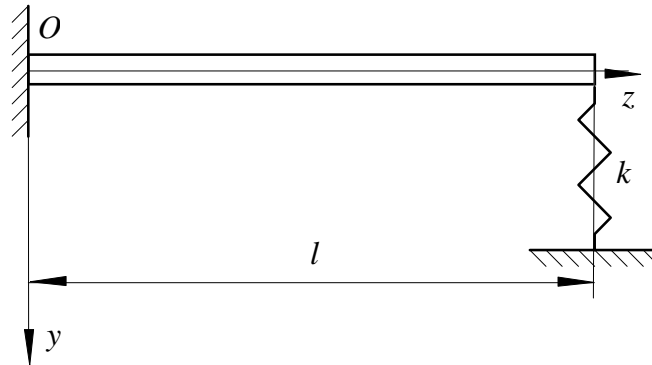

Figure 16

Solution

According to the equation 3.65, the equation of motion of the beam is

$$\frac{\partial^2 y(z, t)}{\partial t^2} + \lambda^2 \frac{\partial^4 y(z, t)}{\partial z^4} = 0 \quad (3.138)$$

Its particular solution can be sought in the following form

$$y(z, t) = Y_n(z) \sin \omega_n t \quad (3.139)$$

the above solution has to fulfill boundary conditions. At the left hand end the displacement and gradient of the beam have to be equal to zero. Hence,

$$y(z, t)|_{z=0} = 0 \quad (3.140)$$

$$\frac{\partial y(z, t)}{\partial z} \Big|_{z=0} = 0 \quad (3.141)$$

The right hand end, with the forces acting on it, is shown in Fig. 17. Equilibrium

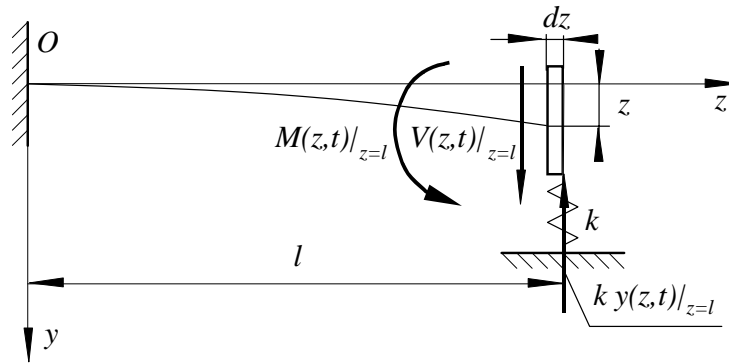

Figure 17

conditions for the element dz which have to be fulfilled for any instant of time, forms the boundary conditions associated with the right hand end

$$M(z, t)|_{z=l} = E(z)J(z) \frac{\partial^2 y(z, t)}{\partial z^2} \Big|_{z=l} = 0 \quad (3.142)$$

$$V(z, t)|_{z=l} = \frac{\partial M(z, t)}{\partial z} \Big|_{z=l} = \frac{\partial}{\partial z} EJ \frac{\partial^2 y(z, t)}{\partial z^2} \Big|_{z=l} = ky(z, t)|_{z=l} \quad (3.143)$$

Introduction of the solution 3.139 into the above boundary conditions yields

$$\begin{aligned} Y_n(z)|_{z=0} &= 0 \\ Y_n^I(z)|_{z=0} &= 0 \\ Y_n^{II}(z)|_{z=l} &= 0 \\ \alpha Y_n^{III}(z)|_{z=l} - Y_n(z)|_{z=l} &= 0 \end{aligned} \quad (3.144)$$

where

$$\alpha = \frac{EJ}{k} \quad (3.145)$$

According to the equations 3.76 to 3.79 the expressions for the natural modes $Y_n(z)$ and their derivatives are

$$\begin{aligned} Y_n(z) &= A_n \sinh \beta_n z + B_n \cosh \beta_n z + C_n \sin \beta_n z + D_n \cos \beta_n z \\ Y_n^I(z) &= A_n \beta_n \cosh \beta_n z + B_n \beta_n \sinh \beta_n z + C_n \beta_n \cos \beta_n z - D_n \beta_n \sin \beta_n z \\ Y_n^{II}(z) &= A_n \beta_n^2 \sinh \beta_n z + B_n \beta_n^2 \cosh \beta_n z - C_n \beta_n^2 \sin \beta_n z - D_n \beta_n^2 \cos \beta_n z \\ Y_n^{III}(z) &= A_n \beta_n^3 \cosh \beta_n z + B_n \beta_n^3 \sinh \beta_n z - C_n \beta_n^3 \cos \beta_n z + D_n \beta_n^3 \sin \beta_n z \end{aligned} \quad (3.146)$$

where (see Eq. 3.69)

$$\beta_n^4 = \frac{\omega_n^2}{\lambda^2} = \frac{A\rho}{EJ} \omega_n^2 \quad (3.147)$$

Introduction of the above expressions into the boundary conditions 3.144 results in the following set of algebraic equations that is linear with respect to the constants A_n , B_n , C_n and D_n .

$$\begin{aligned} B_n + D_n &= 0 \\ A_n + C_n &= 0 \\ A_n \beta_n^2 \sinh \beta_n l + B_n \beta_n^2 \cosh \beta_n l - C_n \beta_n^2 \sin \beta_n l - D_n \beta_n^2 \cos \beta_n l &= 0 \\ A_n \beta_n^3 \alpha \cosh \beta_n l + B_n \beta_n^3 \alpha \sinh \beta_n l - C_n \beta_n^3 \alpha \cos \beta_n l + D_n \beta_n^3 \alpha \sin \beta_n l \\ - (A_n \sinh \beta_n l + B_n \cosh \beta_n l + C_n \sin \beta_n l + D_n \cos \beta_n l) &= 0 \end{aligned} \quad (3.148)$$

The matrix form of these equations is presented below

$$\begin{bmatrix} 0 & 1 & 0 & 1 \\ 1 & 0 & 1 & 0 \\ \sinh \beta_n l & \cosh \beta_n l & -\sin \beta_n l & -\cos \beta_n l \\ \beta_n^3 \alpha \cosh \beta_n l & \beta_n^3 \alpha \sinh \beta_n l & -\beta_n^3 \alpha \cos \beta_n l & \beta_n^3 \alpha \sin \beta_n l \\ -\sinh \beta_n l & -\cosh \beta_n l & -\sin \beta_n l & -\cos \beta_n l \end{bmatrix} \begin{bmatrix} A_n \\ B_n \\ C_n \\ D_n \end{bmatrix} = \begin{bmatrix} 0 \\ 0 \\ 0 \\ 0 \end{bmatrix} \quad (3.149)$$

The non-zero solution of this set of equations exists if and only if its characteristic determinant is equal to zero.

$$\begin{vmatrix} 0 & 1 & 0 & 1 \\ 1 & 0 & 1 & 0 \\ \sinh \beta_n l & \cosh \beta_n l & -\sin \beta_n l & -\cos \beta_n l \\ \beta_n^3 \alpha \cosh \beta_n l & \beta_n^3 \alpha \sinh \beta_n l & -\beta_n^3 \alpha \cos \beta_n l & \beta_n^3 \alpha \sin \beta_n l \\ -\sinh \beta_n l & -\cosh \beta_n l & -\sin \beta_n l & -\cos \beta_n l \end{vmatrix} = 0 \quad (3.150)$$

For the following data

$$E = 2.1 \times 10^{11} \text{ N/m}^2$$

$$\rho = 7800 \text{ kg/m}^3$$

$$A = 0.03 \times 0.01 = 0.0003 \text{ m}^2$$

$$J = \frac{0.03 \times 0.01^3}{12} = 2.5 \times 10^{-9} \text{ m}^4$$

$$k = 10000 \text{ N/m}$$

$$l = 1 \text{ m}$$

$$\alpha = \frac{EJ}{k} = \frac{2.1 \times 10^{11} \times 2.5 \times 10^{-9}}{10000} = 0.0525$$

the characteristic equation takes form

0	1	0	1	= 0
1	0	1	0	
$\sinh \beta_n$	$\cosh \beta_n$	$-\sin \beta_n$	$-\cos \beta_n$	
$.0525 \beta_n^3 \cosh \beta_n$	$.0525 \beta_n^3 \sinh \beta_n$	$-.0525 \beta_n^3 \cos \beta_n$	$.0525 \beta_n^3 \sin \beta_n$	
$-\sinh \beta_n$	$-\cosh \beta_n$	$-\sin \beta_n$	$-\cos \beta_n$	(3.151)

Solution of this equation for its roots β_n is presented in Fig.18

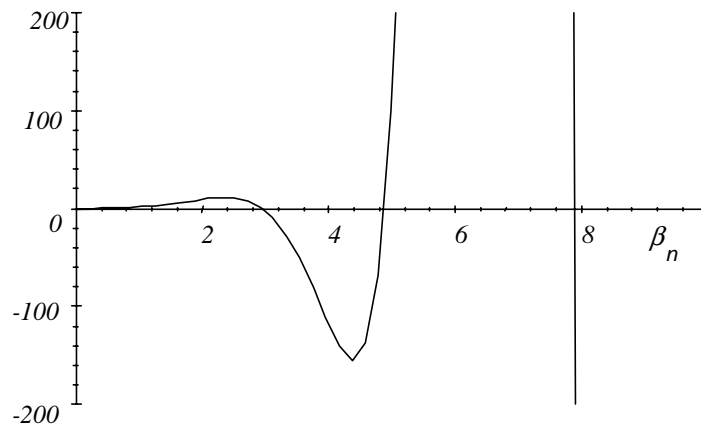

Figure 18

From this diagram the first three roots are

$$\begin{aligned} \beta_1 &= 2.942 \text{ m}^{-1} \\ \beta_2 &= 4.884 \text{ m}^{-1} \\ \beta_3 &= 7.888 \text{ m}^{-1} \end{aligned} \quad (3.152)$$

The relationship 3.147

$$\beta_n^4 = \frac{A\rho}{EJ} \omega_n^2$$

offers values for the wanted natural frequencies

$$\begin{aligned}\omega_1 &= \sqrt{\frac{\beta_1^4 EJ}{A\rho}} = 129.6s^{-1} \\ \omega_2 &= \sqrt{\frac{\beta_2^4 EJ}{A\rho}} = 357.3s^{-1} \\ \omega_3 &= \sqrt{\frac{\beta_3^4 EJ}{A\rho}} = 932.0s^{-1}\end{aligned}\quad (3.153)$$

For each of these roots the set of equations 3.149 becomes linearly dependant. Hence one of the unknown constants can be chosen arbitrarily (e.g. $D_n = 1$) and the last equation can be crossed out. The three remaining equations allow the constants A_n , B_n , and C_n to be computed.

$$\begin{bmatrix} 0 & 1 & 0 & 1 \\ 1 & 0 & 1 & 0 \\ \sinh \beta_n l & \cosh \beta_n l & -\sin \beta_n l & -\cos \beta_n l \end{bmatrix} \begin{bmatrix} A_n \\ B_n \\ C_n \\ 1 \end{bmatrix} = \begin{bmatrix} 0 \\ 0 \\ 0 \end{bmatrix}\quad (3.154)$$

$$\begin{bmatrix} 0 & 1 & 0 \\ 1 & 0 & 1 \\ \sinh \beta_n l & \cosh \beta_n l & -\sin \beta_n l \end{bmatrix} \begin{bmatrix} A_n \\ B_n \\ C_n \end{bmatrix} + \begin{bmatrix} 1 \\ 0 \\ -\cos \beta_n l \end{bmatrix} = \begin{bmatrix} 0 \\ 0 \\ 0 \end{bmatrix}\quad (3.155)$$

$$\begin{bmatrix} A_n \\ B_n \\ C_n \end{bmatrix} = - \begin{bmatrix} 0 & 1 & 0 \\ 1 & 0 & 1 \\ \sinh \beta_n l & \cosh \beta_n l & -\sin \beta_n l \end{bmatrix}^{-1} \begin{bmatrix} 1 \\ 0 \\ -\cos \beta_n l \end{bmatrix}\quad (3.156)$$

For the first three roots the numerical values of these constants are

$$\begin{bmatrix} A_1 \\ B_1 \\ C_1 \end{bmatrix} = \begin{bmatrix} .883 \\ -1.0 \\ -.883 \end{bmatrix}; \quad \begin{bmatrix} A_2 \\ B_2 \\ C_2 \end{bmatrix} = \begin{bmatrix} 1.02 \\ -1.0 \\ -1.02 \end{bmatrix}; \quad \begin{bmatrix} A_3 \\ B_3 \\ C_3 \end{bmatrix} = \begin{bmatrix} 1.0 \\ -1.0 \\ -1.0 \end{bmatrix}\quad (3.157)$$

Introducing them into the first function of 3.146 and remembering that $D_n = 1$, we are getting the corresponding natural modes

$$Y_1(z) = .883 \sinh 2.942z - 1.0 \cosh 2.942z - .883 \sin 2.942z + 1 \cos 2.942z$$

$$Y_2(z) = 1.02 \sinh 4.884z - 1.0 \cosh 4.884z - 1.02 \sin 4.884z + 1 \cos 4.884z$$

$$Y_3(z) = 1.0 \sinh 7.888z - 1.0 \cosh 7.888z - 1.0 \sin 7.888z + 1 \cos 7.888z \quad (3.158)$$

The graphical interpretation of these natural modes is given in Fig. 19

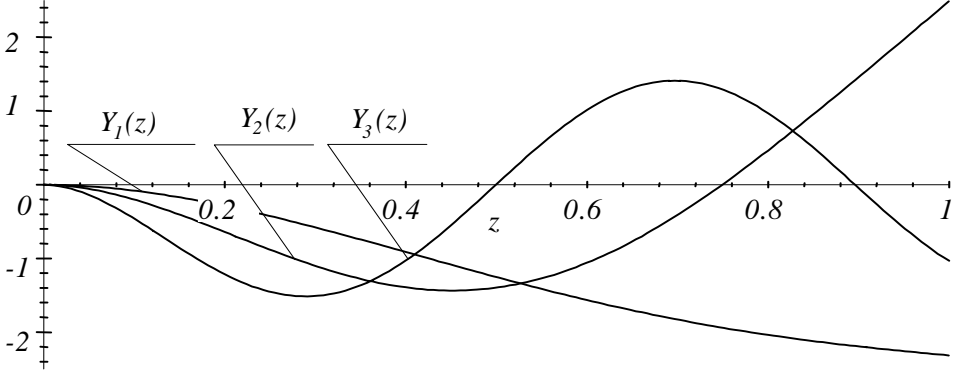

Figure 19

Problem 44

Figure 20

The left hand end of the shaft 1 shown in Fig. 20 is fixed. Its right hand end is supported by means of the massless and rigid beam 2 of length L that is connected to two springs each of the stiffness k . Produce the equation for the natural frequencies of the shaft.

Answer:

$$2 \frac{GJ_o}{kL^2} \frac{\omega_n}{\lambda} \cot \frac{\omega_n l}{\lambda} + 1 = 0 \quad \text{where } \lambda^2 = \frac{G}{\rho}$$

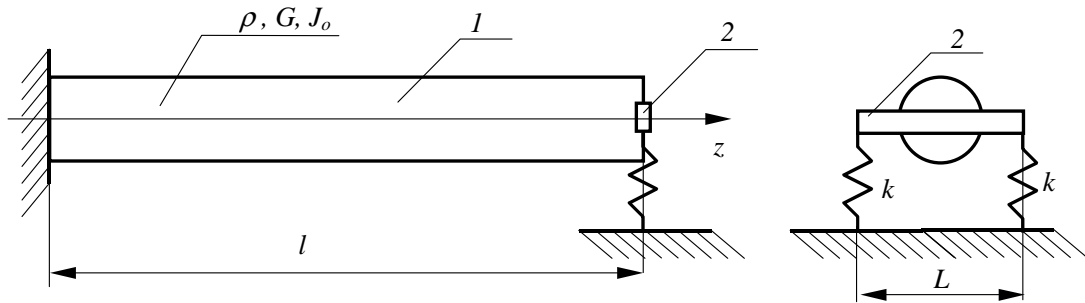
Problem 45

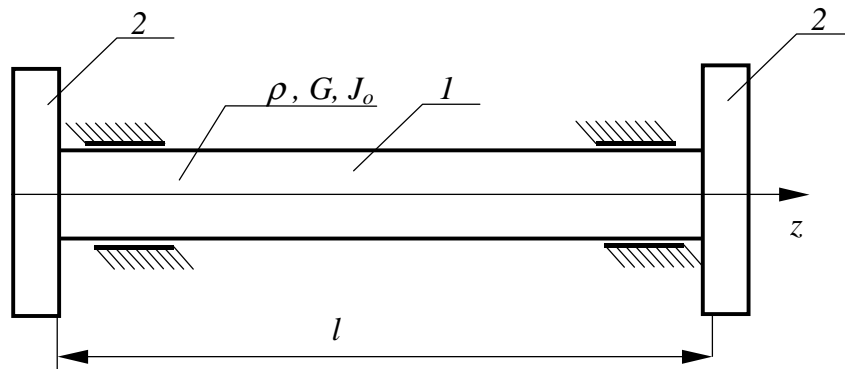

Figure 21

Two rigid discs 2 (see Fig. 21) are joined together by means of the shaft 1 of the length l . The moment of inertia of each disc about the axis z is I .

Produce the equation for the natural frequencies of the assembly.

Answer:

$$\begin{vmatrix} \beta_n & \alpha_n \\ \beta_n \cos \beta_n l - \alpha_n \sin \beta_n l & -\beta_n \sin \beta_n l - \alpha_n \cos \beta_n l \end{vmatrix} = 0$$

where $\beta_n = \omega_n \sqrt{\frac{\rho}{G}}$ $\alpha_n = \frac{I\omega_n^2}{GJ_o}$

Problem 46

Figure 22

The uniform beam is supported as shown in Fig. 22.

Produce the equations for the natural frequencies of this beam

Answer:

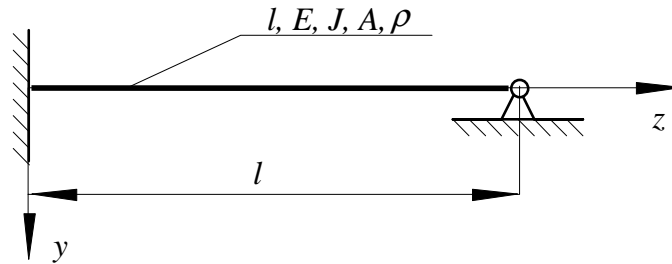
$$\sinh \beta_n l \cos \beta_n l - \sin \beta_n l \cosh \beta_n l = 0 \quad \beta_n = \sqrt{\frac{\omega_n}{\lambda}} \quad \lambda = \frac{EJ}{A\rho}$$

Solution

According to the equation 3.65, the equation of motion of the beam is

$$\frac{\partial^2 y(z, t)}{\partial t^2} + \lambda^2 \frac{\partial^4 y(z, t)}{\partial z^4} = 0 \quad (3.159)$$

Its particular solution can be sought in the following form

$$y(z, t) = Y_n(z) \sin \omega_n t \quad (3.160)$$

the above solution has to fulfill boundary conditions. At the left hand end the displacement and gradient of the beam have to be equal to zero. Hence,

$$y(z, t)|_{z=0} = 0 \quad (3.161)$$

$$\left. \frac{\partial y(z, t)}{\partial z} \right|_{z=0} = 0 \quad (3.162)$$

The right hand end The displacement and the bending moment has to be equal to zero. Hence,

$$y(z, t)|_{z=l} = 0 \quad (3.163)$$

$$M(z, t)|_{z=l} = E(z)J(z) \left. \frac{\partial^2 y(z, t)}{\partial z^2} \right|_{z=l} = 0 \quad (3.164)$$

Introduction of the solution 3.160 into the above boundary conditions yields

$$\begin{aligned} Y_n(z)|_{z=0} &= 0 \\ Y_n^I(z)|_{z=0} &= 0 \\ Y_n(z)|_{z=l} &= 0 \\ Y_n^{II}(z)|_{z=l} &= 0 \end{aligned} \quad (3.165)$$

According to the equations 3.76 to 3.79 the expressions for the natural modes $Y_n(z)$ and their derivatives are

$$\begin{aligned}
 Y_n(z) &= A_n \sinh \beta_n z + B_n \cosh \beta_n z + C_n \sin \beta_n z + D_n \cos \beta_n z \\
 Y_n^I(z) &= A_n \beta_n \cosh \beta_n z + B_n \beta_n \sinh \beta_n z + C_n \beta_n \cos \beta_n z - D_n \beta_n \sin \beta_n z \\
 Y_n^{II}(z) &= A_n \beta_n^2 \sinh \beta_n z + B_n \beta_n^2 \cosh \beta_n z - C_n \beta_n^2 \sin \beta_n z - D_n \beta_n^2 \cos \beta_n z \\
 Y_n^{III}(z) &= A_n \beta_n^3 \cosh \beta_n z + B_n \beta_n^3 \sinh \beta_n z - C_n \beta_n^3 \cos \beta_n z + D_n \beta_n^3 \sin \beta_n z
 \end{aligned} \tag{3.166}$$

where (see Eq. 3.69)

$$\beta_n^4 = \frac{\omega_n^2}{\lambda^2} = \frac{A\rho}{EJ} \omega_n^2 \tag{3.167}$$

Introduction of the above expressions into the boundary conditions 3.165 results in the following set of algebraic equations that is linear with respect to the constants A_n , B_n , C_n and D_n .

$$\begin{aligned}
 B_n + D_n &= 0 \\
 A_n + C_n &= 0 \\
 A_n \sinh \beta_n l + B_n \cosh \beta_n l + C_n \sin \beta_n l + D_n \cos \beta_n l &= 0 \\
 A_n \beta_n^2 \sinh \beta_n l + B_n \beta_n^2 \cosh \beta_n l - C_n \beta_n^2 \sin \beta_n l - D_n \beta_n^2 \cos \beta_n l &= 0
 \end{aligned} \tag{3.168}$$

The matrix form of these equations is presented below

$$\begin{bmatrix} 0 & 1 & 0 & 1 \\ 1 & 0 & 1 & 0 \\ \sinh \beta_n l & \cosh \beta_n l & \sin \beta_n l & \cos \beta_n l \\ \sinh \beta_n l & \cosh \beta_n l & -\sin \beta_n l & -\cos \beta_n l \end{bmatrix} \begin{bmatrix} A_n \\ B_n \\ C_n \\ D_n \end{bmatrix} = \begin{bmatrix} 0 \\ 0 \\ 0 \\ 0 \end{bmatrix} \tag{3.169}$$

The non-zero solution of this set of equations exists if and only if its characteristic determinant is equal to zero.

$$\begin{vmatrix} 0 & 1 & 0 & 1 \\ 1 & 0 & 1 & 0 \\ \sinh \beta_n l & \cosh \beta_n l & \sin \beta_n l & \cos \beta_n l \\ \sinh \beta_n l & \cosh \beta_n l & -\sin \beta_n l & -\cos \beta_n l \end{vmatrix} = 0 \tag{3.170}$$

A development of the above determinant results in the following equation for the unknown parameter $\beta_n l$

$$\beta_n l \sinh \beta_n l \cos \beta_n l - \sin \beta_n l \cosh \beta_n l = 0 \tag{3.171}$$

where:

$$\beta_n = \sqrt{\frac{\omega_n}{\lambda}} \quad \lambda = \frac{EJ}{A\rho} \quad (3.172)$$

The roots $\beta_n l$ of the equation 3.171 allows the natural frequencies to be produced

$$\omega_n = \lambda \beta_n^2 = \lambda \frac{(\beta_n l)^2}{l^2} = \frac{EJ}{A\rho l^2} (\beta_n l)^2 \quad (3.173)$$

Problem 47

Figure 23

The uniform rod 1 shown in Fig. 23 is supported by means of the massless spring of stiffness k .

Produce the equation for the natural frequencies.

Problem 48

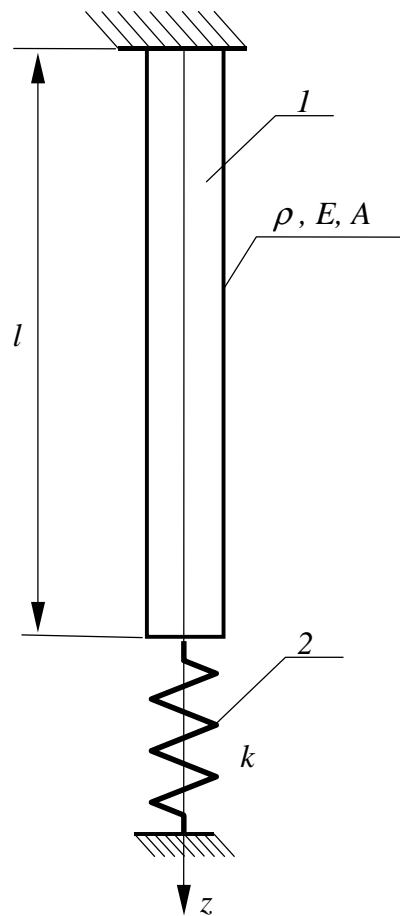
Figure 24

The uniform beam is supported as shown in Fig. 24.

Produce:

1. the boundary conditions for the equation (1)

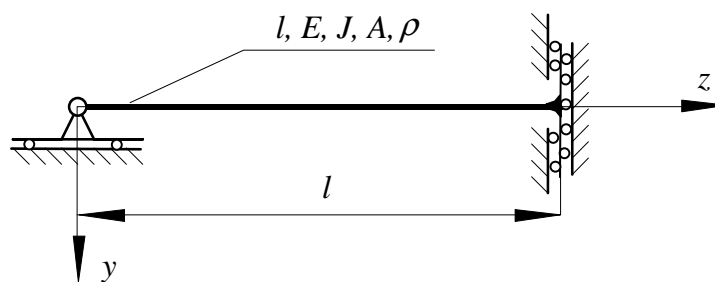
Answer:

$$\text{for } z = 0 \quad (1) Y = 0 \quad (2) Y'' = 0$$

$$\text{for } z = l \quad (3) Y' = 0 \quad (4) Y''' = 0$$

2. the equations for the natural frequencies of this beam

Answer:

$$\cos \beta l = 0$$

$$\text{where } \beta = \sqrt[4]{\frac{EJ}{A\rho\omega^2}}$$

Problem 49

Figure 25

The left hand ends of the two shafts (1 and 2) depicted in the Fig. 25 are welded to a motionless wall. Their right hand ends are welded to the plate 3. The moment of inertia of the plate about the axis z is I_z . This assembly performs the torsional vibration about axis z . The dynamic properties of the shafts are defined by their density ρ_1 and ρ_2 , their shear modulus G_1 and G_2 and the second polar moment of area J_{O1} and J_{O2} respectively.

Produce the equation for the natural frequencies of the assembly described.

The differential equation of motion of a shaft is.

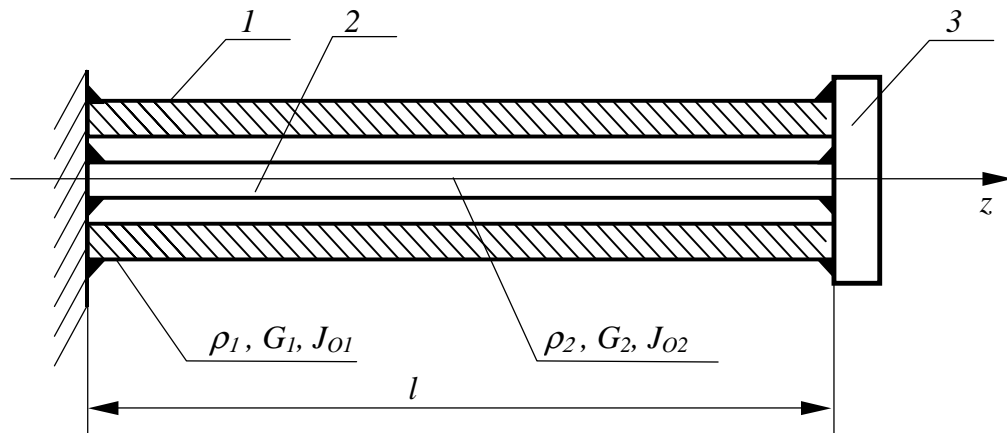
$$\frac{\partial^2 \varphi(z, t)}{\partial t^2} - \lambda^2 \frac{\partial^2 \varphi(z, t)}{\partial z^2} = 0$$

where

$$\lambda^2 = \frac{G}{\rho}$$

G - shear modulus

ρ - density

Answer:

$$\beta_1 \cot \frac{\omega_n l}{\lambda_1} + \beta_2 \cot \frac{\omega_n l}{\lambda_2} = 1; \quad \text{where; } \beta_1 = \frac{J_{O1} \rho_1}{I_z}; \quad \beta_2 = \frac{J_{O2} \rho_2}{I_z}; \quad \lambda_1 = \sqrt{\frac{G_1}{\rho_1}}; \quad \lambda_2 = \sqrt{\frac{G_2}{\rho_2}}$$

Problem 50

Figure 26

The string 1 shown in Fig.26 of length l , density ρ and area of its cross-section A is under the constant tension T . At the position defined by the distance a the element 2 is attached. This element can be treated as a particle of mass m .

Produce the equation for the natural frequencies of the system described.

Solution

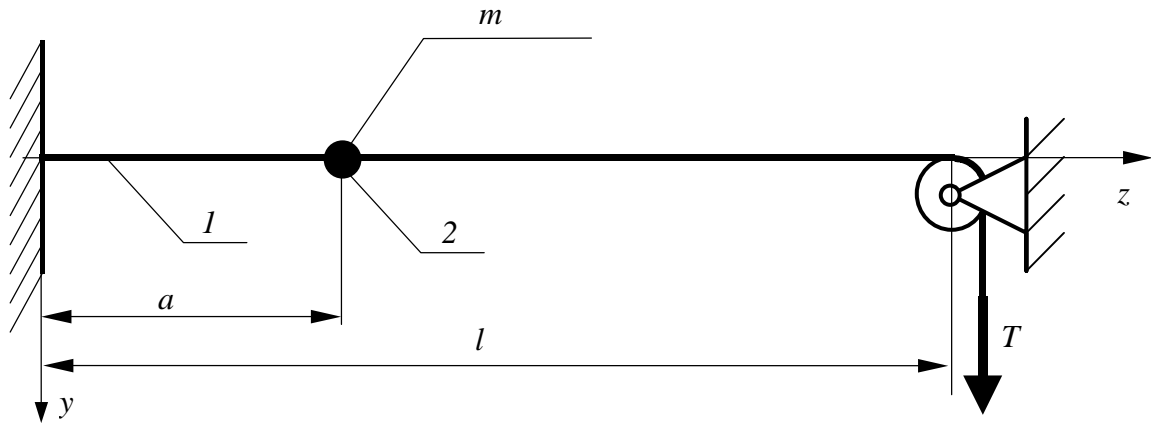
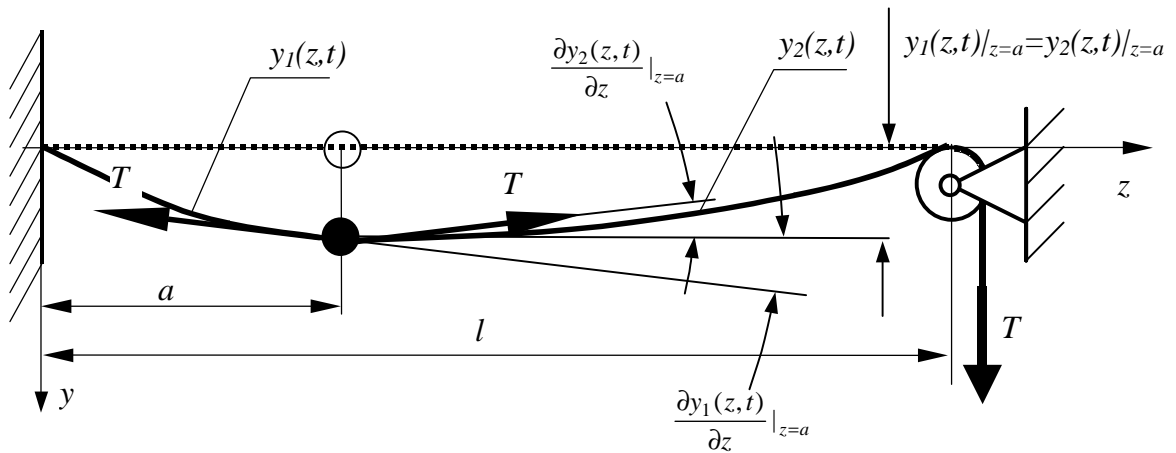

Figure 27

Let the differential equation of motion of the uniform string in the region

$$0 < z < a \quad (3.174)$$

be

$$\frac{\partial^2 y_1(z, t)}{\partial t^2} - \lambda^2 \frac{\partial^2 y_1(z, t)}{\partial z^2} = 0 \quad (3.175)$$

where

$$\lambda^2 = \frac{T}{A\rho} \quad (3.176)$$

Similarly, in the region

$$a < z < l \quad (3.177)$$

the equation of motion is

$$\frac{\partial^2 y_2(z, t)}{\partial t^2} - \lambda^2 \frac{\partial^2 y_2(z, t)}{\partial z^2} = 0 \quad (3.178)$$

where

$$\lambda^2 = \frac{T}{A\rho} \quad (3.179)$$

Solutions of the above equations are of the following form

$$y_{1n}(z, t) = Y_{1n}(z) \sin \omega_n t \quad (3.180)$$

$$y_{2n}(z, t) = Y_{2n}(z) \sin \omega_n t \quad (3.181)$$

where ω_n stands for the natural frequency that is common for both parts of the string.

These solutions must fulfil boundary conditions ($z = 0, z = l$) and compatibility conditions at $z = a$. They are

$$y_{1n}(z, t) |_{z=0} = 0 \quad (3.182)$$

$$y_{1n}(z, t) |_{z=a} = y_{2n}(z, t) |_{z=a} \quad (3.183)$$

$$m \frac{\partial^2 y_1(z, t)}{\partial t^2} \Big|_{z=a} = -T \frac{\partial y_1(z, t)}{\partial z} \Big|_{z=a} + T \frac{\partial y_2(z, t)}{\partial z} \Big|_{z=a} \quad (3.184)$$

$$y_{2n}(z, t) |_{z=l} = 0 \quad (3.185)$$

Introduction of the solutions 3.180 and 3.181 into the equations 3.175 and 3.178 results in the following set of differential equations

$$Y_{1n}''(z) + \beta_n^2 Y_{1n}(z) = 0 \quad (3.186)$$

$$Y_{2n}''(z) + \beta_n^2 Y_{2n}(z) = 0 \quad (3.187)$$

where

$$\beta_n^2 = \frac{\omega_n^2}{\lambda^2} = \frac{A\rho\omega_n^2}{T} \quad (3.188)$$

The general solution of these equations can be predicted as follows

$$Y_{1n}(z) = S_{1n} \sin \beta_n z + C_{1n} \cos \beta_n z \quad (3.189)$$

$$Y_{2n}(z) = S_{2n} \sin \beta_n z + C_{2n} \cos \beta_n z \quad (3.190)$$

Introduction of the solutions 3.180 into the conditions 3.181 yields

$$Y_{1n}(z) |_{z=0} = 0 \quad (3.191)$$

$$Y_{1n}(z) |_{z=a} = Y_{2n}(z) |_{z=a} \quad (3.192)$$

$$-m\omega_n^2 Y_{1n}(z) |_{z=a} = -TY_{1n}'(z) |_{z=a} + TY_{2n}'(z) |_{z=a} \quad (3.193)$$

$$Y_{2n}(z) |_{z=l} = 0 \quad (3.194)$$

Introduction of the solutions 3.189 and 3.190 into the conditions above one can get the following set of homogeneous linear equations

$$\begin{aligned} (0) S_{1n} + (1) C_{1n} + (0) S_{2n} + (0) C_{2n} &= 0 \\ (\sin \beta_n a) S_{1n} + (\cos \beta_n a) C_{1n} - (\sin \beta_n a) S_{2n} - (\cos \beta_n a) C_{2n} &= 0 \\ (-m\omega_n^2 \sin \beta_n a + T\beta_n \cos \beta_n a) S_{1n} + (-m\omega_n^2 \sin \beta_n a - T\beta_n \sin \beta_n a) C_{1n} + \\ &\quad - (T\beta_n \cos \beta_n a) S_{2n} + (T\beta_n \sin \beta_n a) C_{2n} = 0 \\ (0) S_{1n} + (0) C_{1n} + (\sin \beta_n l) S_{2n} + (\cos \beta_n l) C_{2n} &= 0 \end{aligned} \quad (3.195)$$

This set of equations possesses non-trivial solutions if and only if its characteristic determinant is equal to zero.

$$\begin{vmatrix} 0 & 1 & 0 & 0 \\ \sin \beta_n a & \cos \beta_n a & -\sin \beta_n a & -\cos \beta_n a \\ -m\omega_n^2 \sin \beta_n a + T\beta_n \cos \beta_n a & -m\omega_n^2 \sin \beta_n a - T\beta_n \sin \beta_n a & -T\beta_n \cos \beta_n a & T\beta_n \sin \beta_n a \\ 0 & 0 & \sin \beta_n l & \cos \beta_n l \end{vmatrix} = 0 \quad (3.196)$$

Roots β_n of the above equation, with help of the relationship 3.188 allow the natural frequencies to be produced

$$\omega_n = \beta_n \sqrt{\frac{T}{A\rho}}$$

Problem 51

Figure 28

Two strings of length l_1 and l_2 are loaded with tension T . Their dynamic properties are determined by the density ρ and the area of their cross-section A .

Produce the natural frequencies of the system described and the corresponding natural modes

Solution

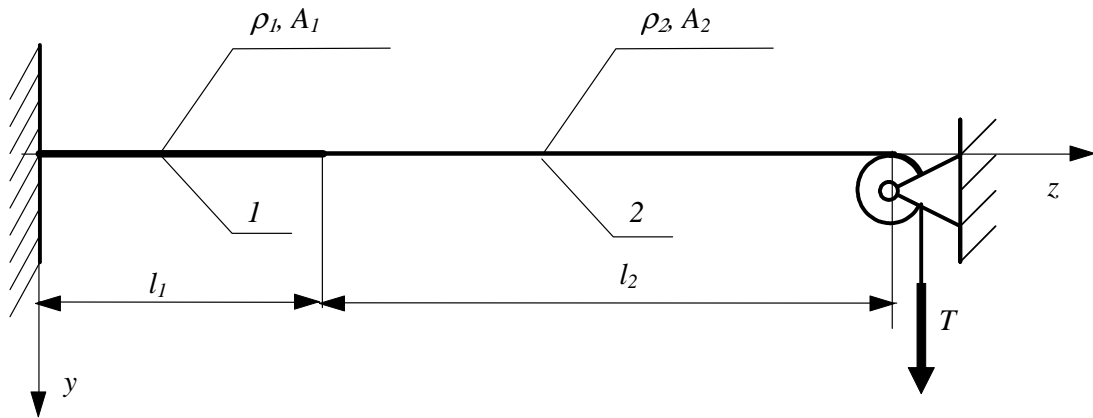
Let the differential equation of motion of the uniform string in the region

$$0 < z < l_1 \quad (3.197)$$

be

$$\frac{\partial^2 y_1(z, t)}{\partial t^2} - \lambda^2 \frac{\partial^2 y_1(z, t)}{\partial z^2} = 0 \quad (3.198)$$

where

$$\lambda_1^2 = \frac{T}{A_1 \rho_1} \quad (3.199)$$

Similarly, in the region

$$l_1 < z < l_1 + l_2 \quad (3.200)$$

the equation of motion is

$$\frac{\partial^2 y_2(z, t)}{\partial t^2} - \lambda^2 \frac{\partial^2 y_2(z, t)}{\partial z^2} = 0 \quad (3.201)$$

where

$$\lambda_2^2 = \frac{T}{A_2 \rho_2} \quad (3.202)$$

Solutions of the above equations are of the following form

$$\begin{aligned} y_{1n}(z, t) &= Y_{1n}(z) \sin \omega_n t \\ y_{2n}(z, t) &= Y_{2n}(z) \sin \omega_n t \end{aligned} \quad (3.203)$$

These solutions must fulfil boundary conditions ($z = 0$, $z = l_1 + l_2$) and compatibility conditions at $z = l_1$. They are

$$\begin{aligned} y_{1n}(z, t) \Big|_{z=0} &= 0 \\ y_{1n}(z, t) \Big|_{z=l_1} &= y_{2n}(z, t) \Big|_{z=l_1+l_2} \\ dm \frac{\partial^2 y_1(z, t)}{\partial t^2} \Big|_{z=l_1} &= -T \frac{\partial y_1(z, t)}{\partial z} \Big|_{z=l_1} + T \frac{\partial y_2(z, t)}{\partial z} \Big|_{z=l_1} \\ y_{2n}(z, t) \Big|_{z=l_1+l_2} &= 0 \end{aligned} \quad (3.204)$$

The third condition we are getting by application of the Newton law to the element of the string associated with $z = l_1$. Since dm stands for an infinitesimal mass of this element, the above conditions can be rewritten as follows

$$\begin{aligned} y_{1n}(z, t) \Big|_{z=0} &= 0 \\ y_{1n}(z, t) \Big|_{z=l_1} &= y_{2n}(z, t) \Big|_{z=l_1+l_2} \\ - \frac{\partial y_1(z, t)}{\partial z} \Big|_{z=l_1} + \frac{\partial y_2(z, t)}{\partial z} \Big|_{z=l_1} &= 0 \\ y_{2n}(z, t) \Big|_{z=l_1+l_2} &= 0 \end{aligned} \quad (3.205)$$

Introduction of the solutions 3.203 into the equations 3.198 and 3.201 results in the following set of differential equations

$$Y_{1n}''(z) + \beta_{n1}^2 Y_{1n}(z) = 0 \quad (3.206)$$

$$Y_{2n}''(z) + \beta_{n2}^2 Y_{2n}(z) = 0 \quad (3.207)$$

where

$$\beta_{1n}^2 = \frac{\omega_n^2}{\lambda_1^2} = \frac{A_1 \rho_1 \omega_n^2}{T}; \quad \beta_{2n}^2 = \frac{\omega_n^2}{\lambda_2^2} = \frac{A_2 \rho_2 \omega_n^2}{T} \quad (3.208)$$

The general solution of these equations can be predicted as follows

$$Y_{1n}(z) = S_{1n} \sin \beta_{1n} z + C_{1n} \cos \beta_{1n} z \quad (3.209)$$

$$Y_{2n}(z) = S_{2n} \sin \beta_{2n} z + C_{2n} \cos \beta_{2n} z \quad (3.210)$$

Introduction of the solutions 3.203 into the conditions 3.205 yields

$$\begin{aligned} Y_{1n}(z) \Big|_{z=0} &= 0 \\ Y_{1n}(z) \Big|_{z=l_1} &= Y_{2n}(z) \Big|_{z=l_1} \\ -Y_{1n}'(z) \Big|_{z=l_1} + Y_{2n}'(z) \Big|_{z=l_1} &= 0 \\ Y_{2n}(z) \Big|_{z=l_1+l_2} &= 0 \end{aligned} \quad (3.211)$$

Introduction of the solutions 3.209 and 3.210 into the conditions above one can get the following set of homogeneous linear equations

$$\begin{aligned} (0) S_{1n} + (1) C_{1n} + (0) S_{2n} + (0) C_{2n} &= 0 \\ (\sin \beta_{1n} l_1) S_{1n} + (\cos \beta_{1n} l_1) C_{1n} - (\sin \beta_{2n} l_1) S_{2n} - (\cos \beta_{2n} l_1) C_{2n} &= 0 \\ (\beta_{1n} \cos \beta_{1n} l_1) S_{1n} - (\beta_{1n} \sin \beta_{1n} l_1) C_{1n} - (\beta_{2n} \cos \beta_{2n} l_1) S_{2n} + (\beta_{2n} \sin \beta_{2n} l_1) C_{2n} &= 0 \\ (0) S_{1n} + (0) C_{1n} + (\sin \beta_{2n} (l_1 + l_2)) S_{2n} + (\cos \beta_{2n} (l_1 + l_2)) C_{2n} &= 0 \end{aligned} \quad (3.212)$$

This set of equations possesses non-trivial solutions if and only if its characteristic determinant is equal to zero.

$$\begin{vmatrix} 0 & 1 & 0 & 0 \\ \sin \beta_{1n} l_1 & \cos \beta_{1n} l_1 & -\sin \beta_{2n} l_1 & -\cos \beta_{2n} l_1 \\ \beta_{1n} \cos \beta_{1n} l_1 & -\beta_{1n} \sin \beta_{1n} l_1 & -\beta_{2n} \cos \beta_{2n} l_1 & +\beta_{2n} \sin \beta_{2n} l_1 \\ 0 & 0 & \sin \beta_{2n} (l_1 + l_2) & \cos \beta_{2n} (l_1 + l_2) \end{vmatrix} = 0 \quad (3.213)$$

Introducing 3.208 into the above equation we have $\beta_{1n} = \frac{\omega_n}{\lambda_1}$

$$\begin{vmatrix} 0 & 1 & 0 & 0 \\ \sin \frac{\omega_n}{\lambda_1} l_1 & \cos \frac{\omega_n}{\lambda_1} l_1 & -\sin \frac{\omega_n}{\lambda_2} l_1 & -\cos \frac{\omega_n}{\lambda_2} l_1 \\ \frac{\omega_n}{\lambda_1} \cos \frac{\omega_n}{\lambda_1} l_1 & -\frac{\omega_n}{\lambda_1} \sin \frac{\omega_n}{\lambda_1} l_1 & -\frac{\omega_n}{\lambda_2} \cos \frac{\omega_n}{\lambda_2} l_1 & +\frac{\omega_n}{\lambda_2} \sin \frac{\omega_n}{\lambda_2} l_1 \\ 0 & 0 & \sin \frac{\omega_n}{\lambda_2} (l_1 + l_2) & \cos \frac{\omega_n}{\lambda_2} (l_1 + l_2) \end{vmatrix} = 0 \quad (3.214)$$

Now, the equation can be solved for the natural frequencies of the string. The solution is presented for the following set of numerical data.

$$l_1 = .5m, l_2 = 1.m, \rho_1 = \rho_2 = 7800kg/m^3, A_1 = 2 \cdot 10^{-6}m^2, A_2 = 1 \cdot 10^{-6}m^2, T = 500N.$$

$$\lambda_1 = \sqrt{\frac{T}{A_1\rho_1}} \sqrt{\frac{500}{2 \cdot 10^{-6} \cdot 7800}} = 179.03m/s, \lambda_2 = \sqrt{\frac{T}{A_2\rho_2}} = \sqrt{\frac{500}{1 \cdot 10^{-6} \cdot 7800}} = 253.18m/s$$

$$\begin{vmatrix} 0 & 1 & 0 & 0 \\ \sin\left(\frac{.5}{179}\omega_n\right) & \cos\left(\frac{.5}{179}\omega_n\right) & -\sin\left(\frac{.5}{253}\omega_n\right) & -\cos\left(\frac{.5}{253}\omega_n\right) \\ \frac{1}{179}\cos\left(\frac{.5}{179}\omega_n\right) & -\frac{1}{179}\sin\left(\frac{.5}{179}\omega_n\right) & -\frac{1}{253}\cos\left(\frac{.5}{253}\omega_n\right) & +\frac{1}{253}\sin\left(\frac{.5}{253}\omega_n\right) \\ 0 & 0 & \sin\left(\frac{1}{253}(.5 + 1.)\omega_n\right) & \cos\left(\frac{1}{253}(.5 + 1.)\omega_n\right) \end{vmatrix} = 0 \quad (3.215)$$

The magnitude of the determinant as a function of the frequency ω_n is presented in Fig. 29

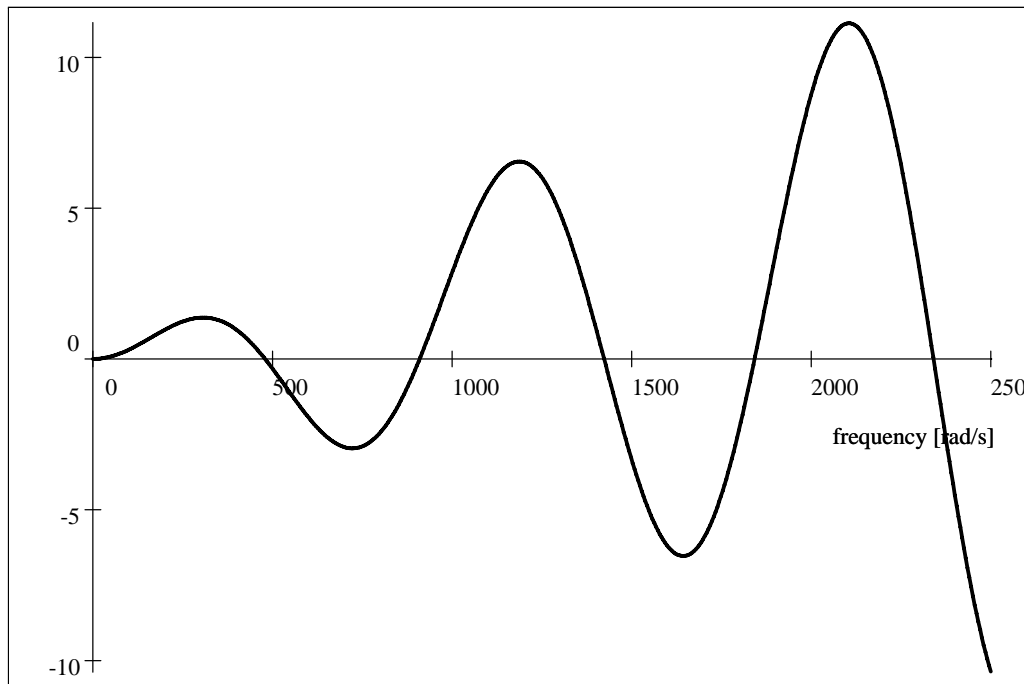

Figure 29

It allows the natural frequencies to be determined. They are

$$\omega_1 = 483; \quad \omega_2 = 920; \quad \omega_3 = 1437; \quad \omega_4 = 1861; \quad \omega_5 = 2344[rad/s] \quad (3.216)$$

The so far unknown constants $S_{1n}, C_{1n}, S_{2n}, C_{2n}$ can be computed from the homogeneous set of linear equations 3.212. From the first equation one can see that the constant C_{1n} must be equal to zero

$$C_{1n} = 0$$

$$\begin{aligned} (\sin \beta_{1n} l_1) S_{1n} - (\sin \beta_{2n} l_1) S_{2n} - (\cos \beta_{2n} l_1) C_{2n} &= 0 \\ (\beta_{1n} \cos \beta_{1n} l_1) S_{1n} - (\beta_{2n} \cos \beta_{2n} l_1) S_{2n} + (\beta_{2n} \sin \beta_{2n} l_1) C_{2n} &= 0 \\ (0) S_{1n} + (\sin \beta_{2n} (l_1 + l_2)) S_{2n} + (\cos \beta_{2n} (l_1 + l_2)) C_{2n} &= 0 \end{aligned} \quad (3.217)$$

Since the equations is linearly dependent for roots of its characteristic determinant, one of them must be crossed out and one of the constant can be assumed arbitrarily. Hence let us crossed out the second equation and assume $C_{2n} = 1$.

$$C_{2n} = 1$$

The set of equations for determination of the remaining constants S_{1n} and S_{2n} is

$$\begin{aligned} (\sin \beta_{1n} l_1) S_{1n} - (\sin \beta_{2n} l_1) S_{2n} &= \cos \beta_{2n} l_1 \\ (0) S_{1n} + (\sin \beta_{2n} (l_1 + l_2)) S_{2n} &= -\cos \beta_{2n} (l_1 + l_2) \end{aligned}$$

Hence

$$\begin{aligned} S_{2n} &= \frac{-\cos \beta_{2n} (l_1 + l_2)}{\sin \beta_{2n} (l_1 + l_2)} \\ S_{1n} &= \frac{\cos \beta_{2n} l_1 - (\sin \beta_{2n} l_1) \frac{\cos \beta_{2n} (l_1 + l_2)}{\sin \beta_{2n} (l_1 + l_2)}}{(\sin \beta_{1n} l_1)} \end{aligned}$$

For $n = 1, 2, 3$ the constants S_{1n} and S_{2n} are

$$n = 1$$

$$\begin{aligned} \omega_1 &= 483; \beta_{11} = \frac{\omega_1}{\lambda_1} = \frac{483}{179.03} = 2.697 \quad \beta_{21} = \frac{\omega_1}{\lambda_2} = \frac{483}{253.18} = 1.91 \\ S_{11} &= \frac{\cos \beta_{21} l_1 - (\sin \beta_{21} l_1) \frac{\cos \beta_{21} (l_1 + l_2)}{\sin \beta_{21} (l_1 + l_2)}}{(\sin \beta_{11} l_1)} = \frac{\cos 1.907 \cdot 0.5 - (\sin 1.907 \cdot 0.5) \frac{\cos 1.907 \cdot 1.5}{\sin 1.907 \cdot 1.5}}{(\sin 2.697 \cdot 0.5)} = 3.48 \\ S_{21} &= \frac{-\cos \beta_{21} (l_1 + l_2)}{\sin \beta_{21} (l_1 + l_2)} = \frac{-\cos 1.907 \cdot 1.5}{\sin 1.907 \cdot 1.5} = 3.46 Y_{11}(z) \\ Y_{11}(z) &= S_{11} \sin \beta_{11} z = 3.48 \sin 2.697 z \quad \text{for } 0 < z < 0.5 \\ Y_{21}(z) &= S_{21} \sin \beta_{21} z + 1 \cos \beta_{21} z = 3.46 \sin 1.91 z + 1 \cos 1.91 z \quad \text{for } 0.5 < z < 1.5 \end{aligned}$$

$$n = 2$$

$$\begin{aligned} \omega_2 &= 920; \beta_{12} = \frac{\omega_2}{\lambda_1} = \frac{920}{179.03} = 5.13 \quad \beta_{22} = \frac{\omega_2}{\lambda_2} = \frac{920}{253.18} = 3.63 \\ S_{12} &= \frac{\cos \beta_{22} l_1 - (\sin \beta_{22} l_1) \frac{\cos \beta_{22} (l_1 + l_2)}{\sin \beta_{22} (l_1 + l_2)}}{(\sin \beta_{12} l_1)} = \frac{\cos 3.63 \cdot 0.5 - (\sin 3.63 \cdot 0.5) \frac{\cos 3.63 \cdot 1.5}{\sin 3.63 \cdot 1.5}}{(\sin 5.13 \cdot 0.5)} = 1.15 \\ S_{22} &= \frac{-\cos \beta_{22} (l_1 + l_2)}{\sin \beta_{22} (l_1 + l_2)} = \frac{-\cos 3.63 \cdot 1.5}{\sin 3.63 \cdot 1.5} = 0.899 \\ Y_{12}(z) &= S_{12} \sin \beta_{12} z = 1.15 \sin 5.13 z \quad \text{for } 0 < z < 0.5 \\ Y_{22}(z) &= S_{22} \sin \beta_{22} z + 1 \cos \beta_{22} z = 0.899 \sin 3.63 z + 1 \cos 3.63 z \quad \text{for } 0.5 < z < 1.5 \end{aligned}$$

$$n = 3$$

$$\begin{aligned} \omega_3 &= 1437; \beta_{13} = \frac{\omega_3}{\lambda_1} = \frac{1437}{179.03} = 8.026 \quad \beta_{23} = \frac{\omega_3}{\lambda_2} = \frac{1437}{253.18} = 5.67 \\ S_{13} &= \frac{\cos \beta_{23} l_1 - (\sin \beta_{23} l_1) \frac{\cos \beta_{23} (l_1 + l_2)}{\sin \beta_{23} (l_1 + l_2)}}{(\sin \beta_{13} l_1)} = \frac{\cos 5.675 \cdot 0.5 - (\sin 5.675 \cdot 0.5) \frac{\cos 5.675 \cdot 1.5}{\sin 5.675 \cdot 1.5}}{(\sin 8.026 \cdot 0.5)} = 0.944 \\ S_{23} &= \frac{-\cos \beta_{23} (l_1 + l_2)}{\sin \beta_{23} (l_1 + l_2)} = \frac{-\cos 5.675 \cdot 1.5}{\sin 5.675 \cdot 1.5} = 0.773 \\ Y_{13}(z) &= S_{13} \sin \beta_{13} z = 0.944 \sin 8.026 z \quad \text{for } 0 < z < 0.5 \\ Y_{23}(z) &= S_{23} \sin \beta_{23} z + 1 \cos \beta_{23} z = 0.773 \sin 5.67 z + 1 \cos 5.67 z \quad \text{for } 0.5 < z < 1.5 \end{aligned}$$

A plot of the natural modes is shown in Fig. 30

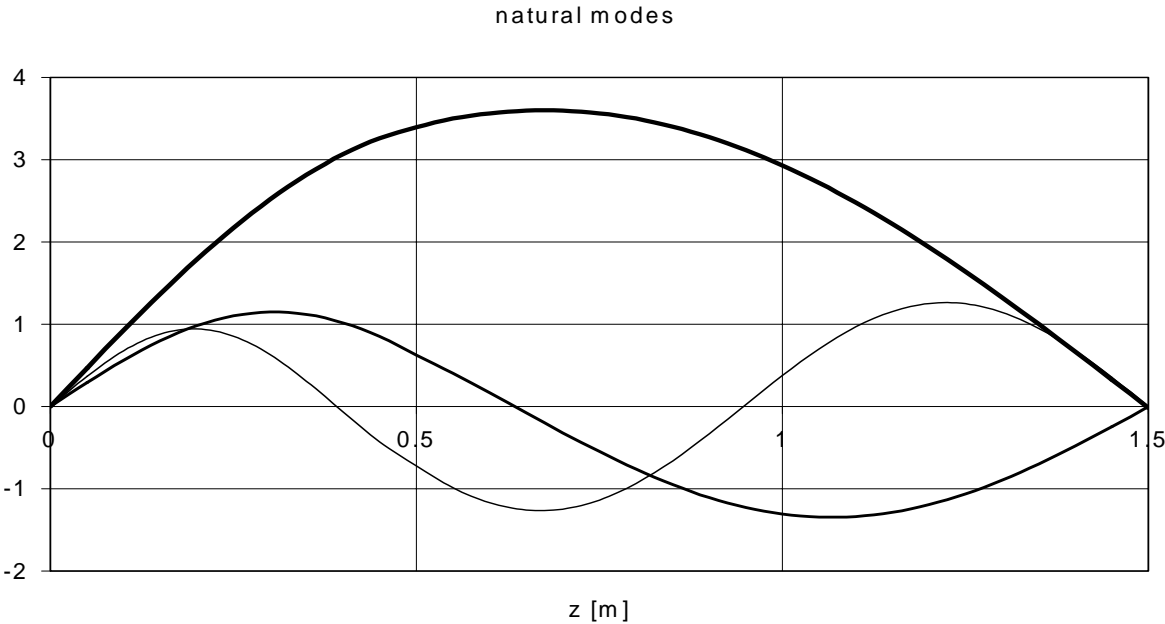

Figure 30

3.3 DISCRETE MODEL OF THE FREE-FREE BEAMS

The commercially available computer packages allow to produce stiffness and inertia matrix of free in space beam along coordinates y_n and φ_{y_n} (see Fig. 31) associated with an arbitrary chosen number N of points. These distinguished points n are called *nodes*. The most popular approaches for creation of the stiffness and inertia matrices

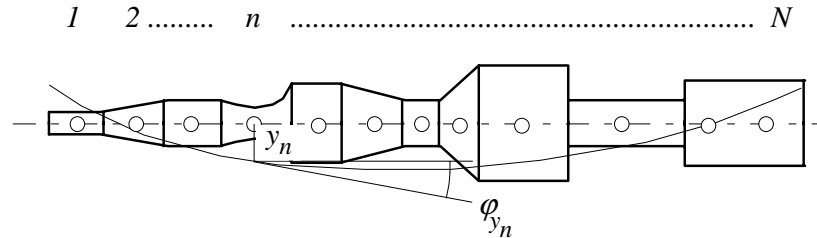

Figure 31

are called *Rigid Element Method* and *Finite Element Method*.

3.3.1 Rigid Elements Method.

Inertia and stiffness matrix for the free-free beam

According to the Rigid Element Method, the beam is divided into a sufficient, for necessary accuracy, number of segments I of constant cross-section (Fig. 32a). The bending and shearing properties of each segment are represented by two springs of stiffness k_{M_i} and k_{T_i} respectively (Fig. 32.b). Equivalence of both, the actual element (Fig. 33a) and its model (Fig. 33b) requires equal angular deflection ($\delta_{r_i} = \delta_{e_i}$) caused by the same bending moment M_i .

Since:

$$\delta_{r_i} = \frac{M_i l_i}{2EJ_i} \quad \text{and} \quad \delta_{e_i} = \frac{M_i}{2k_{M_i}} \quad (3.218)$$

the bending stiffness is

$$k_{M_i} = \frac{EJ_i}{l_i} \quad (3.219)$$

Similarly, the equivalence of shearing deflections ($y_{r_i} = y_{e_i}$) caused by the same shearing force T_i (Fig. 33c and Fig. 33d)

$$y_{r_i} = l_i \gamma_{r_i} = \frac{T_i l_i}{GA_i} \quad \text{and} \quad y_{e_i} = \frac{T_i}{k_{T_i}} \quad (3.220)$$

yields

$$k_{T_i} = \frac{GA_i}{l_i} \quad (3.221)$$

The right hand part of the segment l_{i-1} and the left hand part of the subsequent segment l_i , form a section (Fig. 32c). Each section is considered rigid and its inertia properties are represented by mass m_i and moments of inertia I_i . In this

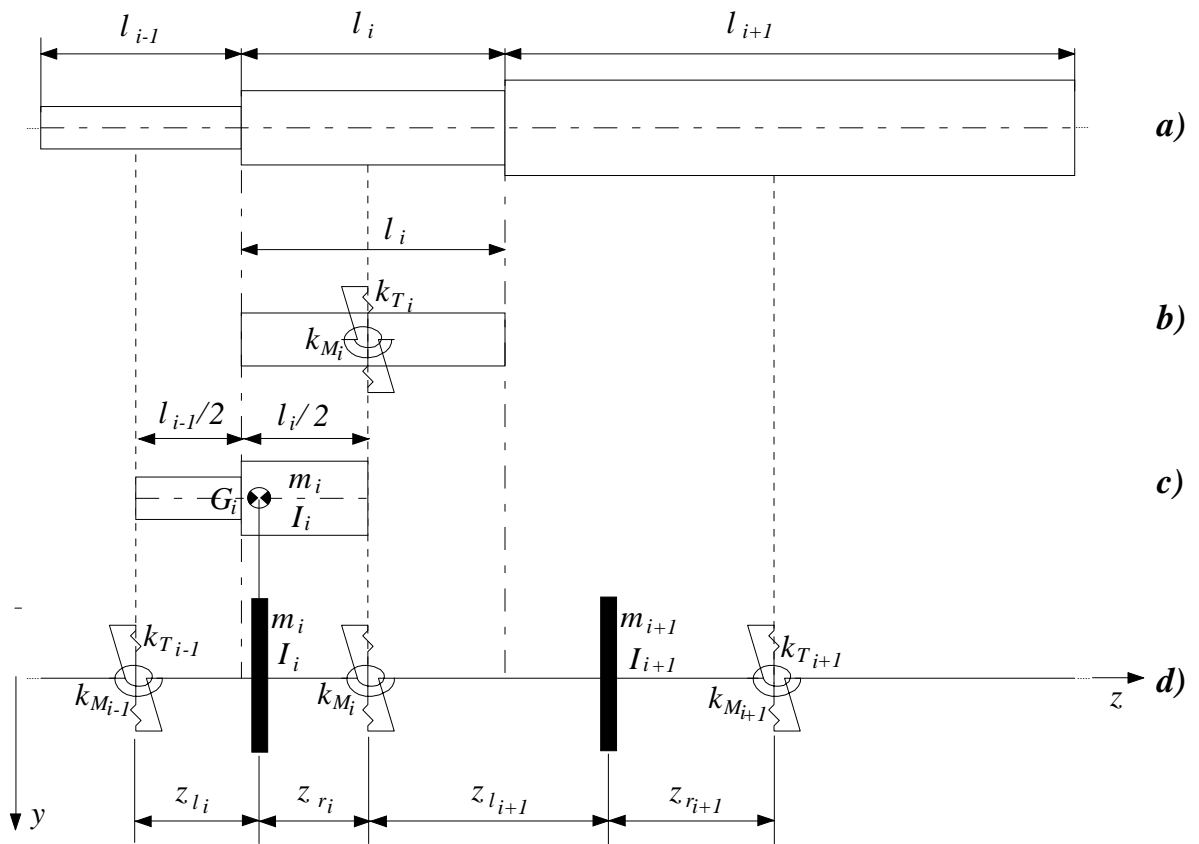

Figure 32

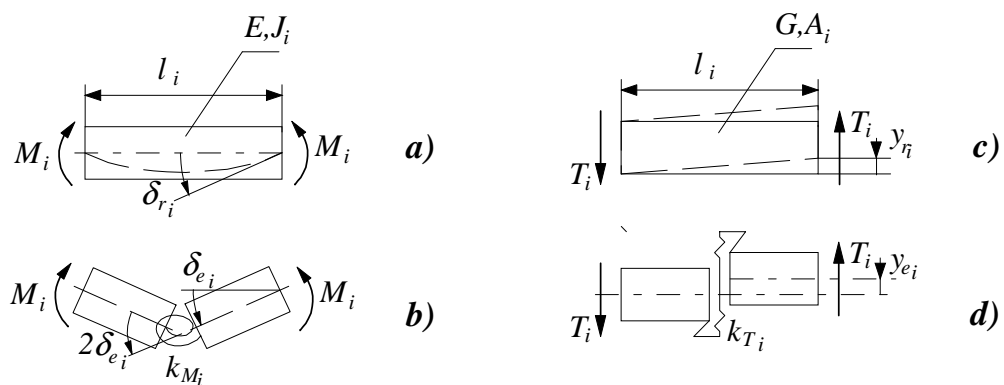

Figure 33

way a complete symmetry is obtained that gives simple programming for computer analysis.

Application of the Lagrange's equations to the physical model is shown in Fig. 32d) results in the following equations of motion.

$$\mathbf{m}\ddot{\mathbf{y}} + \mathbf{k}\mathbf{y} = \mathbf{0} \quad (3.222)$$

where:

$$\mathbf{m} = \begin{bmatrix} \mathbf{M}_{1,1} & \dots & \mathbf{0} & \mathbf{0} & \mathbf{0} & \dots & \mathbf{0} \\ \vdots & \ddots & \vdots & \vdots & \vdots & \ddots & \vdots \\ \mathbf{0} & \dots & \mathbf{M}_{i-1,i-1} & \mathbf{0} & \mathbf{0} & \dots & \mathbf{0} \\ \mathbf{0} & \dots & \mathbf{0} & \mathbf{M}_{i,i} & \mathbf{0} & \dots & \mathbf{0} \\ \mathbf{0} & \dots & \mathbf{0} & \mathbf{0} & \mathbf{M}_{i+1,i+1} & \dots & \mathbf{0} \\ \vdots & \ddots & \vdots & \vdots & \vdots & \ddots & \vdots \\ \mathbf{0} & \dots & \mathbf{0} & \mathbf{0} & \mathbf{0} & \dots & \mathbf{M}_{N,N} \end{bmatrix} \quad (3.223)$$

$$\mathbf{k} = \begin{bmatrix} \mathbf{K}_{1,1} & \dots & \mathbf{0} & \mathbf{0} & \mathbf{0} & \dots & \mathbf{0} \\ \vdots & \ddots & \vdots & \vdots & \vdots & \ddots & \vdots \\ \mathbf{0} & \dots & \mathbf{K}_{i-1,i-1} & \mathbf{K}_{i-1,i} & \mathbf{0} & \dots & \mathbf{0} \\ \mathbf{0} & \dots & \mathbf{K}_{i,i-1} & \mathbf{K}_{i,i} & \mathbf{K}_{i,i+1} & \dots & \mathbf{0} \\ \mathbf{0} & \dots & \mathbf{0} & \mathbf{K}_{i+1,i} & \mathbf{K}_{i+1,i+1} & \dots & \mathbf{0} \\ \vdots & \ddots & \vdots & \vdots & \vdots & \ddots & \vdots \\ \mathbf{0} & \dots & \mathbf{0} & \mathbf{0} & \mathbf{0} & \dots & \mathbf{K}_{N,N} \end{bmatrix} \quad (3.224)$$

$$\mathbf{y}_b = \begin{bmatrix} \mathbf{y}_1 \\ \vdots \\ \mathbf{y}_{i-1} \\ \mathbf{y}_i \\ \mathbf{y}_{i+1} \\ \vdots \\ \mathbf{y}_N \end{bmatrix} \quad (3.225)$$

$$N = I + 1 \quad (3.226)$$

$$\mathbf{M}_{i,i} = \begin{bmatrix} m_i & 0 \\ 0 & I_i \end{bmatrix} \quad (3.227)$$

$$\mathbf{K}_{i,i-1} = \begin{bmatrix} -k_{T_{i-1}} & -k_{T_{i-1}}z_{r_{i-1}} \\ +k_{T_{i-1}}z_{l_i} & -k_{M_{i-1}} + k_{T_{i-1}}z_{r_{i-1}}z_{l_i} \end{bmatrix} \quad (3.228)$$

$$\mathbf{K}_{i,i} = \begin{bmatrix} +k_{T_{i-1}} + k_{T_i} & +k_{T_{i-1}}z_{l_i} + k_{T_i}z_{r_i} \\ +k_{T_{i-1}}z_{l_i} + k_{T_i}z_{r_i} & +k_{M_{i-1}} + k_{T_{i-1}}z_{l_i}^2 + k_{T_i}z_{r_i}^2 \end{bmatrix} \quad (3.229)$$

$$\mathbf{K}_{i,i+1} = \begin{bmatrix} -k_{T_i} & +k_{T_i}z_{l_{i+1}} \\ -k_{T_i}z_{r_i} & -k_{M_i} + k_{T_i}z_{l_{i+1}}z_{r_i} \end{bmatrix} \quad (3.230)$$

$$\mathbf{y}_i = \begin{bmatrix} y_i \\ \varphi_{y_i} \end{bmatrix} \quad (3.231)$$

The geometrical interpretation of the vector of coordinates 3.231 is given in Fig. 34. The coordinates y_i, φ_{y_i} are associated with nodes which are located at the centre of gravity of the rigid elements.

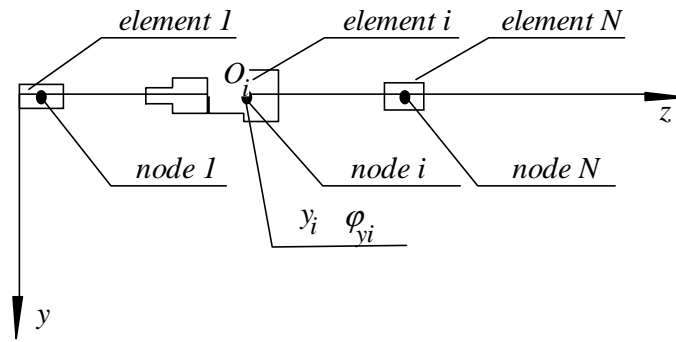

Figure 34

Introduction of the external forces

If there is a set of forces acting on the rigid element, each of them (e.g. \mathbf{F}_i) can be equivalently replaced by the force \mathbf{F}_i applied to the node O_i and the moment $\mathbf{M}_i = a_i \cdot \mathbf{F}_i$ as shown in Fig. 35. This equivalent set of forces along the nodal coordinates

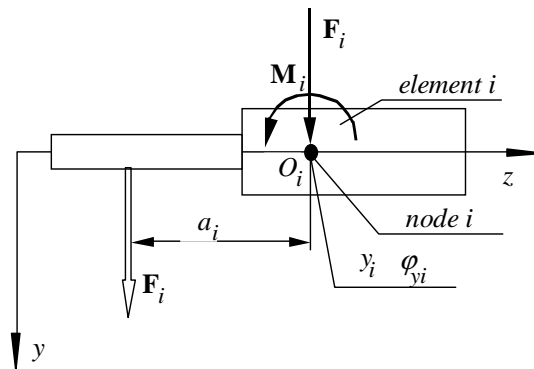

Figure 35

y_i, φ_{yi} should be added to the mathematical model 3.232. In a general case these forces can be independent of time (static forces) or they can depend on time (excitation forces). Introducing notations \mathbf{F}_s for the static forces and $\mathbf{F}(t)$ for the excitation forces, the equation of motion of the free-free beam takes the following form.

$$m\ddot{y} + ky = \mathbf{F}_s + \mathbf{F}(t) \quad (3.232)$$

3.3.2 Finite Elements Method.

Inertia and stiffness matrix for the free-free beam

According to the Finite Elements Method, the shaft is divided into a number of the uniform and flexible elements. The i -th element is shown in Fig. 36.

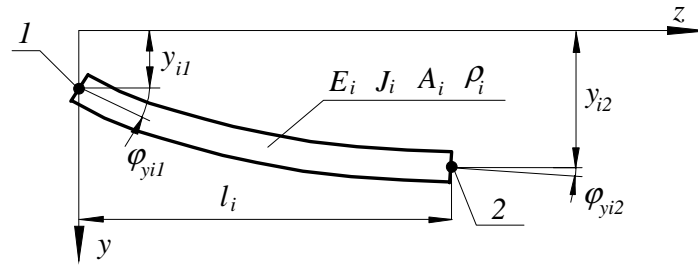

Figure 36

In this figure E_i , J_i , A_i , and ρ_i stand for Young modulus, second moment of area about the neutral axis, area of cross-section and the unit mass of the element. The differential equation of the statically deflected line of the element in the plane yz is

$$E_i J_i \frac{d^4 y(z)}{dz^4} = 0 \tag{3.233}$$

Integration of the above equation four times yields

$$y(z) = \frac{1}{6} C_1 z^3 + \frac{1}{2} C_2 z^2 + C_3 z + C_4 \tag{3.234}$$

The constants of integration C_j ($j = 1, 2, 3, 4$) must be chosen to fulfill the following boundary conditions

$$y(z)|_{z=0} = y_{i1}; \quad \left. \frac{dy(z)}{dz} \right|_{z=0} = \varphi_{yi1} \quad y(z)|_{z=l_i} = y_{i2}; \quad \left. \frac{dy(z)}{dz} \right|_{z=l_i} = \varphi_{yi2} \tag{3.235}$$

The parameters y_{i1} and y_{i2} are called *nodal displacements* and the parameters φ_{i1} and φ_{i2} are called *nodal rotations*. The nodes are denoted by numbers 1 and 2. Introduction of solution 3.234 into the above boundary conditions results in the following set of algebraic equations linear with respect to the constants C_j .

$$\begin{bmatrix} 0 & 0 & 0 & 1 \\ 0 & 0 & 1 & 0 \\ \frac{1}{6} l_i^3 & \frac{1}{2} l_i^2 & l_i & 1 \\ \frac{1}{2} l_i^2 & l_i & 1 & 0 \end{bmatrix} \begin{bmatrix} C_1 \\ C_2 \\ C_3 \\ C_4 \end{bmatrix} = \begin{bmatrix} y_{i1} \\ \varphi_{yi1} \\ y_{i2} \\ \varphi_{yi2} \end{bmatrix} \tag{3.236}$$

Its solution yields the integration constants C_j .

$$\begin{bmatrix} C_1 \\ C_2 \\ C_3 \\ C_4 \end{bmatrix} = \begin{bmatrix} 0 & 0 & 0 & 1 \\ 0 & 0 & 1 & 0 \\ \frac{1}{6} l_i^3 & \frac{1}{2} l_i^2 & l_i & 1 \\ \frac{1}{2} l_i^2 & l_i & 1 & 0 \end{bmatrix}^{-1} \begin{bmatrix} y_{i1} \\ \varphi_{yi1} \\ y_{i2} \\ \varphi_{yi2} \end{bmatrix} = \begin{bmatrix} \frac{6}{l_i^3} (2y_{i1} + l_i \varphi_{yi1} - 2y_{i2} + l_i \varphi_{yi2}) \\ \frac{2}{l_i^2} (-3y_{i1} - 2l_i \varphi_{yi1} + 3y_{i2} - l_i \varphi_{yi2}) \\ \varphi_{yi1} \\ y_{i1} \end{bmatrix} \tag{3.237}$$

After introduction of Eq. 3.237 into the equation of the deflected line 3.234 one may get it in the following form.

$$\begin{aligned}
 y(z) &= \left[1 - 3 \left(\frac{z}{l_i} \right)^2 + 2 \left(\frac{z}{l_i} \right)^3 \right] y_{i1} + \left[\left(\frac{z}{l_i} \right) - 2 \left(\frac{z}{l_i} \right)^2 + \left(\frac{z}{l_i} \right)^3 \right] l_i \varphi_{yi1} \\
 &+ \left[3 \left(\frac{z}{l_i} \right)^2 - 2 \left(\frac{z}{l_i} \right)^3 \right] y_{i2} + \left[- \left(\frac{z}{l_i} \right)^2 + \left(\frac{z}{l_i} \right)^3 \right] l_i \varphi_{yi2} \\
 &= \{H(z)\}^T \{y\}
 \end{aligned} \tag{3.238}$$

where:

$$\{H(z)\} = \begin{Bmatrix} H_1 \\ H_2 l_i \\ H_3 \\ H_4 l_i \end{Bmatrix} = \begin{Bmatrix} 1 - 3 \left(\frac{z}{l_i} \right)^2 + 2 \left(\frac{z}{l_i} \right)^3 \\ \left[\left(\frac{z}{l_i} \right) - 2 \left(\frac{z}{l_i} \right)^2 + \left(\frac{z}{l_i} \right)^3 \right] l_i \\ 3 \left(\frac{z}{l_i} \right)^2 - 2 \left(\frac{z}{l_i} \right)^3 \\ \left[- \left(\frac{z}{l_i} \right)^2 + \left(\frac{z}{l_i} \right)^3 \right] l_i \end{Bmatrix} \tag{3.239}$$

$$\{y\} = \begin{Bmatrix} y_{i1} \\ \varphi_{yi1} \\ y_{i2} \\ \varphi_{yi2} \end{Bmatrix} \tag{3.240}$$

Functions H_1, H_2, H_3, H_4 (see Eq. 3.239) are known as *Hermite cubics* or *shape functions*. The matrix $\{y\}$ contains the *nodal coordinates*. As it can be seen from Eq. 3.238 the deflected line of the finite element is assembled of terms which are linear with respect to the nodal coordinates.

If the finite element performs motion with respect to the stationary system of coordinates xyz , it is assumed that the motion in the plane yz can be approximated by the following equation.

$$y(z, t) = \{H(z)\}^T \{y(t)\} \tag{3.241}$$

As one can see from the equation 3.241, the dynamic deflection line is approximated by the static deflection line. It should be noted that this assumption is acceptable only if the considered element is reasonably short.

The following mathematical manipulations are aimed to replace the continues mathematical model of the element considered

$$E_i J_i \frac{\partial^4 y(z, t)}{\partial z^4} - \rho_i \frac{\partial^2 y(z, t)}{\partial t^2} = 0 \tag{3.242}$$

by its discreet representation along the nodal coordinates

$$[m_i] \{\ddot{y}(t)\} + [k_i] \{y(t)\} = 0. \tag{3.243}$$

In the above equations ρ_i stands for the unit mass of the finite element and $[m_i]$ and $[k_i]$ stands for the inertia and stiffness matrix respectively. These two matrices are going to be developed from the two following criterions:

1. The kinetic energy of the continues physical model of the finite element must be equal to the kinetic energy of its discreet physical model.

2. The potential energy of the continues physical model of the finite element must be equal to the potential energy of its discreet physical model.

The kinetic energy of the continues physical model of the finite element is

$$\begin{aligned}
 T &= \frac{1}{2} \int_0^{l_i} \rho_i \left(\frac{\partial y(z, t)}{\partial t} \right)^2 dz \\
 &= \frac{1}{2} \int_0^{l_i} \rho_i \left(\frac{\partial y(z, t)}{\partial t} \right) \left(\frac{\partial y(z, t)}{\partial t} \right) dz \\
 &= \frac{1}{2} \int_0^{l_i} \rho_i \left(\{\dot{y}(t)\}^T \{H(z)\} \right) \left(\{H(z)\}^T \{\dot{y}(t)\} \right) dz \\
 &= \frac{1}{2} \{\dot{y}(t)\}^T \left[\rho_i \int_0^{l_i} \{H(z)\} \{H(z)\}^T dz \right] \{\dot{y}(t)\} \\
 &= \frac{1}{2} \{\dot{y}(t)\}^T \left(\rho_i \int_0^{l_i} \begin{bmatrix} H_1^2 & H_1 H_2 l_i & H_1 H_3 & H_1 H_4 l_i \\ H_2 H_1 l_i & H_2^2 l_i^2 & H_2 H_3 l_i & H_2 H_4 l_i^2 \\ H_3 H_1 & H_3 H_2 l_i & H_3^2 & H_3 H_4 l_i \\ H_4 H_1 l_i & H_4 H_2 l_i^2 & H_4 H_3 l_i & H_4^2 l_i^2 \end{bmatrix} dz \right) \{\dot{y}(t)\}
 \end{aligned} \tag{3.244}$$

It is easy to see that the last row of Eq. 3.244 represents kinetic energy function of the discreet physical model along the nodal coordinates y_{i1} φ_{yi1} y_{i2} φ_{yi2} with the following matrix of inertia.

$$\begin{aligned}
 \mathbf{m}_i &= \rho_i \int_0^{l_i} \begin{bmatrix} H_1^2 & H_1 H_2 l_i & H_1 H_3 & H_1 H_4 l_i \\ H_2 H_1 l_i & H_2^2 l_i^2 & H_2 H_3 l_i & H_2 H_4 l_i^2 \\ H_3 H_1 & H_3 H_2 l_i & H_3^2 & H_3 H_4 l_i \\ H_4 H_1 l_i & H_4 H_2 l_i^2 & H_4 H_3 l_i & H_4^2 l_i^2 \end{bmatrix} dz \\
 &= \rho_i l_i \begin{bmatrix} \frac{13}{35} & \frac{11}{210} l_i & \frac{9}{70} & -\frac{13}{420} l_i \\ \frac{11}{210} l_i & \frac{1}{105} l_i^2 & \frac{13}{420} l_i & -\frac{1}{140} l_i^2 \\ \frac{9}{70} & \frac{13}{420} l_i & \frac{13}{35} & -\frac{11}{210} l_i \\ -\frac{13}{420} l_i & -\frac{1}{140} l_i^2 & -\frac{11}{210} l_i & \frac{1}{105} l_i^2 \end{bmatrix} \\
 &= m_i \begin{bmatrix} \frac{13}{35} & \frac{11}{210} l_i & \frac{9}{70} & -\frac{13}{420} l_i \\ \frac{11}{210} l_i & \frac{1}{105} l_i^2 & \frac{13}{420} l_i & -\frac{1}{140} l_i^2 \\ \frac{9}{70} & \frac{13}{420} l_i & \frac{13}{35} & -\frac{11}{210} l_i \\ -\frac{13}{420} l_i & -\frac{1}{140} l_i^2 & -\frac{11}{210} l_i & \frac{1}{105} l_i^2 \end{bmatrix}
 \end{aligned} \tag{3.245}$$

In the last formula m_i stands for mass of the finite element.

To take advantage of the second criterion let us produce expression for the

potential energy function for the continuous physical model of the finite element.

$$\begin{aligned}
V &= \frac{1}{2} \int_0^{l_i} E_i J_i \left(\frac{\partial^2 y(z, t)}{\partial z^2} \right)^2 dz \\
&= \frac{1}{2} \int_0^{l_i} E_i J_i \left(\frac{\partial^2 y(z, t)}{\partial z^2} \right) \left(\frac{\partial^2 y(z, t)}{\partial z^2} \right) dz \\
&= \frac{1}{2} \int_0^{l_i} E_i J_i \left(\{y(t)\}^T \left\{ \frac{d^2 H(z)}{dz^2} \right\} \right) \left(\left\{ \frac{d^2 H(z)}{dz^2} \right\}^T \{y(t)\} \right) dz \\
&= \frac{1}{2} \{y(t)\}^T \left[E_i J_i \int_0^{l_i} \left\{ \frac{d^2 H(z)}{dz^2} \right\} \left\{ \frac{d^2 H(z)}{dz^2} \right\}^T dz \right] \{y(t)\} \\
&= \frac{1}{2} \{y(t)\}^T \left(E_i J_i \int_0^{l_i} \begin{bmatrix} (H_1'')^2 & H_1'' H_2'' l_i & H_1'' H_3'' & H_1'' H_4'' l_i \\ H_2'' H_1'' l_i & (H_2'')^2 l_i^2 & H_2'' H_3'' l_i & H_2'' H_4'' l_i^2 \\ H_3'' H_1'' & H_3'' H_2'' l_i & (H_3'')^2 & H_3'' H_4'' l_i \\ H_4'' H_1'' l_i & H_4'' H_2'' l_i^2 & H_4'' H_3'' l_i & (H_4'')^2 l_i^2 \end{bmatrix} dz \right) \{y(t)\}
\end{aligned} \tag{3.246}$$

As one can see from Eq. 3.246, to fulfill the second criterion, the stiffness matrix along the nodal coordinates y_{i1} φ_{yi1} y_{i2} φ_{yi2} must be as follows.

$$\begin{aligned}
\mathbf{k}_i &= E_i J_i \int_0^{l_i} \begin{bmatrix} (H_1'')^2 & H_1'' H_2'' l_i & H_1'' H_3'' & H_1'' H_4'' l_i \\ H_2'' H_1'' l_i & (H_2'')^2 l_i^2 & H_2'' H_3'' l_i & H_2'' H_4'' l_i^2 \\ H_3'' H_1'' & H_3'' H_2'' l_i & (H_3'')^2 & H_3'' H_4'' l_i \\ H_4'' H_1'' l_i & H_4'' H_2'' l_i^2 & H_4'' H_3'' l_i & (H_4'')^2 l_i^2 \end{bmatrix} dz \\
&= \frac{E_i J_i}{l_i^3} \begin{bmatrix} 12 & 6l_i & -12 & 6l_i \\ 6l_i & 4l_i^2 & -6l_i & 2l_i^2 \\ -12 & -6l_i & 12 & -6l_i \\ 6l_i & 2l_i^2 & -6l_i & 4l_i^2 \end{bmatrix}
\end{aligned} \tag{3.247}$$

Hence, the mathematical model of the element considered can be written as

$$\mathbf{m}_i \ddot{\mathbf{y}}_i + \mathbf{k}_i \mathbf{y}_i = \mathbf{R}_{yi} \tag{3.248}$$

The vector \mathbf{R}_i represents the interaction forces between the neighborhood elements.

$$\mathbf{R}_{yi} = [R_{yi1} \quad R_{\varphi yi1} \quad R_{yi2} \quad R_{\varphi yi2}]^T \tag{3.249}$$

In exactly the same manner one can create mathematical model for the next to the right hand side element of the shaft, say element j .

$$\mathbf{m}_j \ddot{\mathbf{y}}_j + \mathbf{k}_j \mathbf{y}_j = \mathbf{R}_{yj} \tag{3.250}$$

where:

$$\mathbf{m}_j = m_j \begin{bmatrix} \frac{13}{35} & \frac{11}{210}l_j & \frac{9}{70} & -\frac{13}{420}l_j \\ \frac{11}{210}l_j & \frac{1}{105}l_j^2 & \frac{13}{420}l_j & -\frac{1}{140}l_j^2 \\ \frac{9}{70} & \frac{13}{420}l_j & \frac{13}{35} & -\frac{11}{210}l_j \\ -\frac{13}{420}l_j & -\frac{1}{140}l_j^2 & -\frac{11}{210}l_j & \frac{1}{105}l_j^2 \end{bmatrix}$$

$$\mathbf{k}_j = \frac{E_j A_j}{l_j^3} \begin{bmatrix} 12 & 6l_j & -12 & 6l_j \\ 6l_j & 4l_j^2 & -6l_j & 2l_j^2 \\ -12 & -6l_j & 12 & -6l_j \\ 6l_j & 2l_j^2 & -6l_j & 4l_j^2 \end{bmatrix} \quad (3.251)$$

$$\mathbf{y}_j = [y_{j1} \quad \varphi_{yj1} \quad y_{j2} \quad \varphi_{yj2}]^T \quad (3.252)$$

$$\mathbf{R}_{yi} = [R_{yj1} \quad R_{\varphi yj1} \quad R_{yj2} \quad R_{\varphi yj2}]^T \quad (3.253)$$

These two equations of motion (3.248-3.250), associated with the two elements i and j , have to fulfill the *compatibility (continuity and equilibrium) conditions*. These conditions allow to join those two elements to create one mathematical model representing both elements. In the case considered here, the compatibility conditions between the two elements i and j correspond to the left hand side node of the element i and the right hand side node of the element j . For these nodes the continuity conditions take form

$$\begin{bmatrix} y_{i2} \\ \varphi_{yi2} \end{bmatrix} = \begin{bmatrix} y_{j1} \\ \varphi_{yj1} \end{bmatrix} = \begin{bmatrix} y_{ij} \\ \varphi_{yij} \end{bmatrix} \quad (3.254)$$

and the equilibrium conditions are

$$\begin{bmatrix} R_{yi2} \\ R_{\varphi yi2} \end{bmatrix} + \begin{bmatrix} R_{yj1} \\ R_{\varphi yj1} \end{bmatrix} = \begin{bmatrix} 0 \\ 0 \end{bmatrix} \quad (3.255)$$

They result in the following mathematical model of the joint elements.

$$\mathbf{m}_{ij}\ddot{\mathbf{y}}_{ij} + \mathbf{k}_{ij}\mathbf{y}_{ij} = \mathbf{R}_{yij} \quad (3.256)$$

where:

$$\mathbf{m}_{ij} = \begin{bmatrix} \frac{13}{35}m_i & \frac{11}{210}l_i m_i & \frac{9}{70}m_i & -\frac{13}{420}l_i m_i & 0 & 0 \\ \frac{11}{210}l_i m_i & \frac{1}{105}l_i^2 m_i & \frac{13}{420}l_i m_i & -\frac{1}{140}l_i^2 m_i & 0 & 0 \\ \frac{9}{70}m_i & \frac{13}{420}l_i m_i & \frac{13}{35}(m_i + m_j) & \frac{11}{210}(-l_i m_i + l_j m_j) & \frac{9}{70}m_j & -\frac{13}{420}l_j m_j \\ -\frac{13}{420}l_i m_i & -\frac{1}{140}l_i^2 m_i & \frac{11}{210}(-l_i m_i + l_j m_j) & \frac{1}{105}(l_i^2 m_i + l_j^2 m_j) & \frac{13}{420}l_j m_j & -\frac{1}{140}l_j^2 m_j \\ 0 & 0 & \frac{9}{70}m_j & \frac{13}{420}l_j m_j & \frac{13}{35}m_j & -\frac{11}{210}l_j m_j \\ 0 & 0 & -\frac{13}{420}l_j m_j & -\frac{1}{140}l_j^2 m_j & -\frac{11}{210}l_j m_j & \frac{1}{105}l_j^2 m_j \end{bmatrix} \quad (3.257)$$

$$\mathbf{k}_{ij} = \begin{bmatrix} 12 \frac{E_i A_i}{l_i^3} & 6 \frac{E_i A_i}{l_i^2} & -12 \frac{E_i A_i}{l_i^3} & 6 \frac{E_i A_i}{l_i^2} & 0 & 0 \\ 6 \frac{E_i A_i}{l_i^2} & 4 \frac{E_i A_i}{l_i} & -6 \frac{E_i A_i}{l_i^2} & 2 \frac{E_i A_i}{l_i} & 0 & 0 \\ -129 \frac{E_i A_i}{l_i^3} & -6 \frac{E_i A_i}{l_i^2} & 12 \left(\frac{E_i A_i}{l_i^3} + \frac{E_j A_j}{l_j^3} \right) & 6 \left(-\frac{E_i A_i}{l_i^2} + \frac{E_j A_j}{l_j^2} \right) & -12 \frac{E_j A_j}{l_j^3} & 6 \frac{E_j A_j}{l_j^2} \\ 6 \frac{E_i A_i}{l_i^2} & 2 \frac{E_i A_i}{l_i} & 6 \left(-\frac{E_i A_i}{l_i^2} + \frac{E_j A_j}{l_j^2} \right) & 4 \left(\frac{E_i A_i}{l_i} + \frac{E_j A_j}{l_j} \right) & -6 \frac{E_j A_j}{l_j^2} & 2 \frac{E_j A_j}{l_j} \\ 0 & 0 & -12 \frac{E_j A_j}{l_j^3} & -6 \frac{E_j A_j}{l_j^2} & 12 \frac{E_j A_j}{l_j^3} & -6 \frac{E_j A_j}{l_j^2} \\ 0 & 0 & 6 \frac{E_j A_j}{l_j^2} & 2 \frac{E_j A_j}{l_j} & -6 \frac{E_j A_j}{l_j^2} & 4 \frac{E_j A_j}{l_j} \end{bmatrix} \tag{3.258}$$

$$\mathbf{y}_{ij} = [y_{i1} \quad \varphi_{yi1} \quad y_{ij} \quad \varphi_{yij} \quad y_{j2} \quad \varphi_{yj2}]^T \tag{3.259}$$

$$\mathbf{R}_{ij} = [R_{yi1} \quad R_{\varphi yi1} \quad 0 \quad 0 \quad R_{yj2} \quad R_{\varphi yj2}]^T \tag{3.260}$$

Repetition of the described procedure to all elements of the shaft results in the mathematical model of the shaft in the plane yz .

$$\mathbf{m}\ddot{\mathbf{y}} + \mathbf{k}\mathbf{y} = \mathbf{0} \tag{3.261}$$

The geometrical interpretation of the nodal coordinates appearing in the Eq. 3.259 is given in Fig. 37. The coordinates y_i, φ_{yi} are associated with nodes which are located

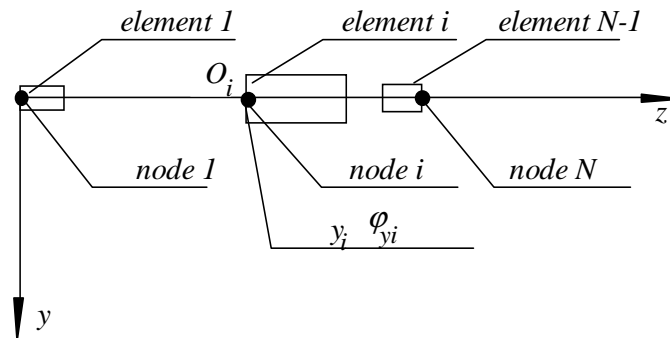

Figure 37

at the ends of the finite elements.

Introduction of the external forces

Since the finite element is considered elastic, the treatment of the external forces presented in the previous section can not be applied. In this case one has to take advantage of the principle of the virtual work. It says that the virtual work produced by a force \mathbf{F}_i (see Fig. 38) on the displacement y_i is equal to the virtual work produced by a set of forces along the coordinates $y_{i1} \quad \varphi_{yi1} \quad y_{i2} \quad \varphi_{yi2}$. Hence

$$\partial W_i = \mathbf{F}_i \cdot \mathbf{y}_i(a_i, t) = \{ F_{i1}, M_{i1}, F_{i2}, M_{i2} \} \begin{Bmatrix} y_{i1} \\ \varphi_{yi1} \\ y_{i2} \\ \varphi_{yi2} \end{Bmatrix} \tag{3.262}$$

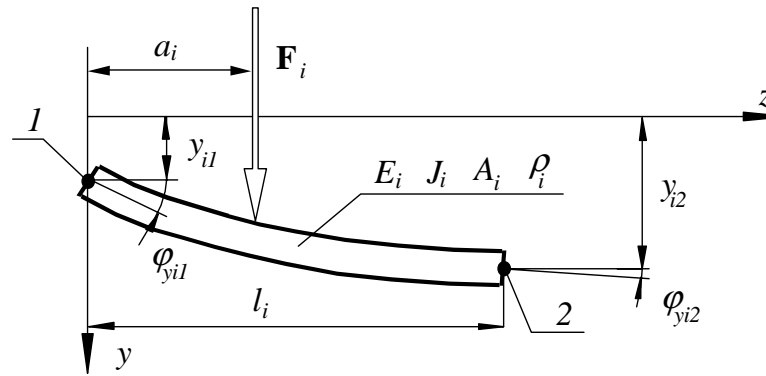

Figure 38

But according to 3.241

$$y(a_i, t) = \{H(a_i)\}^T \{y(t)\} = \begin{Bmatrix} 1 - 3\left(\frac{a_i}{l_i}\right)^2 + 2\left(\frac{a_i}{l_i}\right)^3 \\ \left[\left(\frac{a_i}{l_i}\right) - 2\left(\frac{a_i}{l_i}\right)^2 + \left(\frac{a_i}{l_i}\right)^3\right] l_i \\ 3\left(\frac{a_i}{l_i}\right)^2 - 2\left(\frac{a_i}{l_i}\right)^3 \\ \left[-\left(\frac{a_i}{l_i}\right)^2 + \left(\frac{a_i}{l_i}\right)^3\right] l_i \end{Bmatrix}^T \begin{Bmatrix} y_{i1} \\ \varphi_{yi1} \\ y_{i2} \\ \varphi_{yi2} \end{Bmatrix} \quad (3.263)$$

Introduction of the above expression into the expression for the virtual work yields

$$\partial W_i = F_i \cdot \begin{Bmatrix} 1 - 3\left(\frac{a_i}{l_i}\right)^2 + 2\left(\frac{a_i}{l_i}\right)^3 \\ \left[\left(\frac{a_i}{l_i}\right) - 2\left(\frac{a_i}{l_i}\right)^2 + \left(\frac{a_i}{l_i}\right)^3\right] l_i \\ 3\left(\frac{a_i}{l_i}\right)^2 - 2\left(\frac{a_i}{l_i}\right)^3 \\ \left[-\left(\frac{a_i}{l_i}\right)^2 + \left(\frac{a_i}{l_i}\right)^3\right] l_i \end{Bmatrix}^T \begin{Bmatrix} y_{i1} \\ \varphi_{yi1} \\ y_{i2} \\ \varphi_{yi2} \end{Bmatrix} \quad (3.264)$$

Hence, the vector of forces along the nodal coordinates is

$$\begin{Bmatrix} F_{i1} \\ M_{i1} \\ F_{i2} \\ M_{i2} \end{Bmatrix} = F_i \cdot \begin{Bmatrix} 1 - 3\left(\frac{a_i}{l_i}\right)^2 + 2\left(\frac{a_i}{l_i}\right)^3 \\ \left[\left(\frac{a_i}{l_i}\right) - 2\left(\frac{a_i}{l_i}\right)^2 + \left(\frac{a_i}{l_i}\right)^3\right] l_i \\ 3\left(\frac{a_i}{l_i}\right)^2 - 2\left(\frac{a_i}{l_i}\right)^3 \\ \left[-\left(\frac{a_i}{l_i}\right)^2 + \left(\frac{a_i}{l_i}\right)^3\right] l_i \end{Bmatrix} \quad (3.265)$$

This forces have to be introduced into the equation of motion 3.261

$$m\ddot{\mathbf{y}} + \mathbf{k}\mathbf{y} = \mathbf{F}_s + \mathbf{F}(t) \quad (3.266)$$

where, similarly as before, \mathbf{F}_s stands for the static forces and $\mathbf{F}(t)$ stands for the excitation forces.

3.4 BOUNDARY CONDITIONS

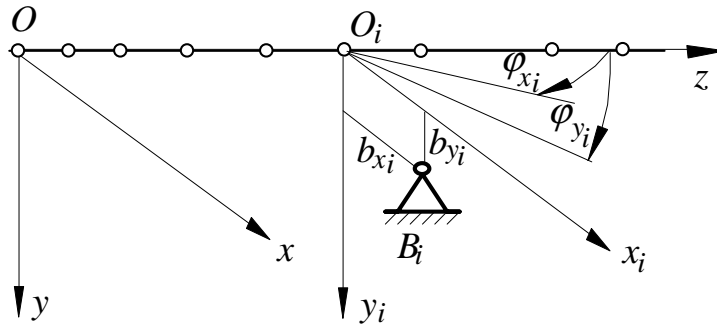

Figure 39

Let us assume that the free-free beam is rigidly supported upon several supports B_i (see Fig. 39). The instantaneous position of these supports is determine with respect to the stationary system of coordinates xyz by coordinates $b_{y_i}(t)$. Let us denote by \mathbf{b} vector of such coordinates.

$$\mathbf{b} = \begin{bmatrix} \vdots \\ b_{y_i}(t) \\ \vdots \end{bmatrix} \tag{3.267}$$

Let us reorganize vector of coordinates of the shaft

$$\mathbf{y} = \{ \varphi_{xN}, y_1 \varphi_{y1}, \dots, y_N \varphi_{yN} \}^T \tag{3.268}$$

in such a way that its upper part \mathbf{y}_b contains coordinates along which the shaft is rigidly supported and its lower part \mathbf{y}_r contains all the remaining coordinates

$$\mathbf{y} = \begin{bmatrix} \mathbf{y}_b \\ \mathbf{y}_r \end{bmatrix} \tag{3.269}$$

Let us assume that the mathematical model of the beam

$$\mathbf{m}\ddot{\mathbf{y}} + \mathbf{k}\mathbf{y} = \mathbf{F} \tag{3.270}$$

is organized with respect to the above vector \mathbf{y} of coordinates.

$$\begin{bmatrix} \mathbf{m}_{bb} & \mathbf{m}_{br} \\ \mathbf{m}_{rb} & \mathbf{m}_{rr} \end{bmatrix} \begin{bmatrix} \ddot{\mathbf{y}}_b \\ \ddot{\mathbf{y}}_r \end{bmatrix} + \begin{bmatrix} \mathbf{k}_{bb} & \mathbf{k}_{br} \\ \mathbf{k}_{rb} & \mathbf{k}_{rr} \end{bmatrix} \begin{bmatrix} \mathbf{y}_b \\ \mathbf{y}_r \end{bmatrix} = \begin{bmatrix} \mathbf{F}_b \\ \mathbf{F}_r \end{bmatrix} \tag{3.271}$$

Partitioning of the above equations results in the following set of equations

$$\begin{aligned} \mathbf{m}_{bb}\ddot{\mathbf{y}}_b + \mathbf{m}_{br}\ddot{\mathbf{y}}_r + \mathbf{k}_{bb}\mathbf{y}_b + \mathbf{k}_{br}\mathbf{y}_r &= \mathbf{F}_b \\ \mathbf{m}_{rb}\ddot{\mathbf{y}}_b + \mathbf{m}_{rr}\ddot{\mathbf{y}}_r + \mathbf{k}_{rb}\mathbf{y}_b + \mathbf{k}_{rr}\mathbf{y}_r &= \mathbf{F}_r \end{aligned} \tag{3.272}$$

Motion of the beam along the coordinates \mathbf{y}_b is determined by the boundary conditions 3.267. Hence, the vector \mathbf{y}_b in the mathematical model 3.272 must be replaced by \mathbf{b} .

$$\begin{aligned} \mathbf{m}_{bb}\ddot{\mathbf{b}} + \mathbf{m}_{br}\ddot{\mathbf{y}}_r + \mathbf{k}_{bb}\mathbf{b} + \mathbf{k}_{br}\mathbf{y}_r &= \mathbf{F}_b \\ \mathbf{m}_{rb}\ddot{\mathbf{b}} + \mathbf{m}_{rr}\ddot{\mathbf{y}}_r + \mathbf{k}_{rb}\mathbf{b} + \mathbf{k}_{rr}\mathbf{y}_r &= \mathbf{F}_r \end{aligned} \quad (3.273)$$

The second equation governs motion of the supported beam and can be rewritten as follows

$$\mathbf{m}_{rr}\ddot{\mathbf{y}}_r + \mathbf{k}_{rr}\mathbf{y}_r = \mathbf{F}_r - \mathbf{m}_{rb}\ddot{\mathbf{b}} - \mathbf{k}_{rs}\mathbf{b}_b \quad (3.274)$$

The last two terms represent the kinematic excitation of the beam cause by motion of its supports. The vector \mathbf{b} , in a general case, is a known function of time. Hence the above equation can be solved. Let

$$\mathbf{y}_r = \mathbf{Y}_r(t) \quad (3.275)$$

be a solution of this equation. This solution approximate motion of the beam along the remaining coordinates \mathbf{y}_r .

The vector \mathbf{F}_b in the first equation of the set 3.273 represents the forces of interaction between the moving beam and its supports. These interaction forces can be now determined.

$$\mathbf{F}_b = \mathbf{m}_{bb}\ddot{\mathbf{b}} + \mathbf{m}_{br}\ddot{\mathbf{Y}}_r + \mathbf{k}_{bb}\mathbf{b} + \mathbf{k}_{br}\mathbf{Y}_r(t) \quad (3.276)$$

3.5 CONDENSATION OF THE DISCREET SYSTEMS

In many engineering problems, due to large number of the uniform sections of the element to be modeled, number of the final elements is large too. It follows that the size of the matrices involved in the discrete mathematical model

$$\mathbf{m}\ddot{\mathbf{y}} + \mathbf{c}\dot{\mathbf{y}} + \mathbf{k}\mathbf{y} = \mathbf{F} \quad (3.277)$$

is too large to enable the necessary analysis of the mathematical model to be carried out. In this section the procedures for reducing the size of mathematical models will be developed.

Let us assume, that the equation 3.277 is arranged in such a way that the coordinates which are to be eliminated due to the condensation procedure \mathbf{y}_e are located in the upper part of the vector \mathbf{y} and these which are to be retained for further consideration \mathbf{y}_r are located in its lower part.

$$\mathbf{y} = \begin{bmatrix} \mathbf{y}_e \\ \mathbf{y}_r \end{bmatrix} \quad (3.278)$$

Partitioning of the equations 3.277 yields

$$\begin{bmatrix} \mathbf{m}_{ee} & \mathbf{m}_{er} \\ \mathbf{m}_{re} & \mathbf{m}_{rr} \end{bmatrix} \begin{bmatrix} \ddot{\mathbf{y}}_e \\ \ddot{\mathbf{y}}_r \end{bmatrix} + \begin{bmatrix} \mathbf{c}_{ee} & \mathbf{c}_{er} \\ \mathbf{c}_{re} & \mathbf{c}_{rr} \end{bmatrix} \begin{bmatrix} \dot{\mathbf{y}}_e \\ \dot{\mathbf{y}}_r \end{bmatrix} + \begin{bmatrix} \mathbf{k}_{ee} & \mathbf{k}_{er} \\ \mathbf{k}_{re} & \mathbf{k}_{rr} \end{bmatrix} \begin{bmatrix} \mathbf{y}_e \\ \mathbf{y}_r \end{bmatrix} = \begin{bmatrix} \mathbf{F}_e \\ \mathbf{F}_r \end{bmatrix} \quad (3.279)$$

To eliminate the coordinates \mathbf{y}_e from the mathematical model 3.279, one have to determine the relationship between the coordinates \mathbf{y}_e and the coordinates \mathbf{y}_r . One of many possibilities is to assume that the coordinates \mathbf{y}_e are obeyed to the static relationship.

$$\begin{bmatrix} \mathbf{k}_{ee} & \mathbf{k}_{er} \\ \mathbf{k}_{re} & \mathbf{k}_{rr} \end{bmatrix} \begin{bmatrix} \mathbf{y}_e \\ \mathbf{y}_r \end{bmatrix} = \begin{bmatrix} \mathbf{0} \\ \mathbf{0} \end{bmatrix} \quad (3.280)$$

Hence, upon partitioning equation 3.280 one may obtain

$$\mathbf{k}_{ee}\mathbf{y}_e + \mathbf{k}_{er}\mathbf{y}_r = \mathbf{0} \quad (3.281)$$

Therefore the sought relationship is

$$\mathbf{y}_e = \mathbf{h}\mathbf{y}_r \quad (3.282)$$

where

$$\mathbf{h} = -\mathbf{k}_{ee}^{-1}\mathbf{k}_{er} \quad (3.283)$$

Once the relationship is established, one may formulate the following criteria of condensation:

1. Kinetic energy of the system before and after condensation must be the same.
2. Dissipation function of the system before and after condensation must be the same.
3. Potential energy of the system before and after condensation must be the same.
4. Virtual work done by all the external forces before and after condensation must be the same.

3.5.1 Condensation of the inertia matrix.

According to the first criterion, the kinetic energy of the system before and after condensation must be the same. The kinetic energy of the system before condensation is

$$\begin{aligned} T &= \frac{1}{2} \begin{bmatrix} \dot{\mathbf{y}}_e^T & \dot{\mathbf{y}}_r^T \end{bmatrix} \begin{bmatrix} \mathbf{m}_{ee} & \mathbf{m}_{er} \\ \mathbf{m}_{re} & \mathbf{m}_{rr} \end{bmatrix} \begin{bmatrix} \dot{\mathbf{y}}_e \\ \dot{\mathbf{y}}_r \end{bmatrix} \\ &= \frac{1}{2} (\dot{\mathbf{y}}_e^T \mathbf{m}_{ee} \dot{\mathbf{y}}_e + \dot{\mathbf{y}}_e^T \mathbf{m}_{er} \dot{\mathbf{y}}_r + \dot{\mathbf{y}}_r^T \mathbf{m}_{re} \dot{\mathbf{y}}_e + \dot{\mathbf{y}}_r^T \mathbf{m}_{rr} \dot{\mathbf{y}}_r) \end{aligned} \quad (3.284)$$

Introduction of 3.282 yields

$$\begin{aligned} T &= \frac{1}{2} \left([\mathbf{h}\dot{\mathbf{y}}_r]^T \mathbf{m}_{ee} \mathbf{h}\dot{\mathbf{y}}_r + [\mathbf{h}\dot{\mathbf{y}}_r]^T \mathbf{m}_{er} \dot{\mathbf{y}}_r + \dot{\mathbf{y}}_r^T \mathbf{m}_{re} \mathbf{h}\dot{\mathbf{y}}_r + \dot{\mathbf{y}}_r^T \mathbf{m}_{rr} \dot{\mathbf{y}}_r \right) \\ &= \frac{1}{2} (\dot{\mathbf{y}}_r^T \mathbf{h}^T \mathbf{m}_{ee} \mathbf{h} \dot{\mathbf{y}}_r + \dot{\mathbf{y}}_r^T \mathbf{h}^T \mathbf{m}_{er} \dot{\mathbf{y}}_r + \dot{\mathbf{y}}_r^T \mathbf{m}_{re} \mathbf{h} \dot{\mathbf{y}}_r + \dot{\mathbf{y}}_r^T \mathbf{m}_{rr} \dot{\mathbf{y}}_r) \\ &= \frac{1}{2} (\dot{\mathbf{y}}_r^T [\mathbf{h}^T \mathbf{m}_{ee} \mathbf{h} + \mathbf{h}^T \mathbf{m}_{er} + \mathbf{m}_{re} \mathbf{h} + \mathbf{m}_{rr}] \dot{\mathbf{y}}_r) \end{aligned} \quad (3.285)$$

Hence, if the kinetic energy after condensation is to be the same, the inertia matrix after condensation \mathbf{m}_c must be equal to

$$\mathbf{m}_c = \mathbf{h}^T \mathbf{m}_{ee} \mathbf{h} + \mathbf{h}^T \mathbf{m}_{er} + \mathbf{m}_{re} \mathbf{h} + \mathbf{m}_{rr} \quad (3.286)$$

3.5.2 Condensation of the damping matrix.

Since formula for the dissipation function is of the same form as formula for the kinetic energy, repetition of the above derivation leads to the following definition of the condensed damping matrix

$$\mathbf{c}_c = \mathbf{h}^T \mathbf{c}_{ee} \mathbf{h} + \mathbf{h}^T \mathbf{c}_{er} + \mathbf{c}_{re} \mathbf{h} + \mathbf{c}_{rr} \quad (3.287)$$

3.5.3 Condensation of the stiffness matrix.

Taking advantage from definition of potential energy of the system considered

$$\begin{aligned} V &= \frac{1}{2} \begin{bmatrix} \mathbf{y}_e^T & \mathbf{y}_r^T \end{bmatrix} \begin{bmatrix} \mathbf{k}_{ee} & \mathbf{k}_{er} \\ \mathbf{k}_{re} & \mathbf{k}_{rr} \end{bmatrix} \begin{bmatrix} \mathbf{y}_e \\ \mathbf{y}_r \end{bmatrix} \\ &= \frac{1}{2} (\mathbf{y}_e^T \mathbf{k}_{ee} \mathbf{y}_e + \mathbf{y}_e^T \mathbf{k}_{er} \mathbf{y}_r + \mathbf{y}_r^T \mathbf{k}_{re} \mathbf{y}_e + \mathbf{y}_r^T \mathbf{k}_{rr} \mathbf{y}_r) \end{aligned} \quad (3.288)$$

one can arrive to conclusion that the condensed stiffness matrix is of the form 3.289

$$\mathbf{k}_c = \mathbf{h}^T \mathbf{k}_{ee} \mathbf{h} + \mathbf{h}^T \mathbf{k}_{er} + \mathbf{k}_{re} \mathbf{h} + \mathbf{k}_{rr} \quad (3.289)$$

It is easy to show that sum of the first two terms in the above expression is equal to zero. Indeed, according to 3.283, they can be transformed as following.

$$\begin{aligned} \mathbf{h}^T \mathbf{k}_{ee} \mathbf{h} + \mathbf{h}^T \mathbf{k}_{er} &= (-\mathbf{k}_{ee}^{-1} \mathbf{k}_{er})^T \mathbf{k}_{ee} (-\mathbf{k}_{ee}^{-1} \mathbf{k}_{er}) + (-\mathbf{k}_{ee}^{-1} \mathbf{k}_{er})^T \mathbf{k}_{er} \\ &= -(-\mathbf{k}_{ee}^{-1} \mathbf{k}_{er})^T \mathbf{k}_{er} + (-\mathbf{k}_{ee}^{-1} \mathbf{k}_{er})^T \mathbf{k}_{er} = \mathbf{0} \end{aligned} \quad (3.290)$$

Hence,

$$\mathbf{k}_c = \mathbf{k}_{re} \mathbf{h} + \mathbf{k}_{rr} \quad (3.291)$$

3.5.4 Condensation of the external forces.

The virtual work performed by external forces \mathbf{F} on the displacements \mathbf{y} is

$$\delta W = \begin{bmatrix} \mathbf{y}_e^T & \mathbf{y}_r^T \end{bmatrix} \begin{bmatrix} \mathbf{F}_e \\ \mathbf{F}_r \end{bmatrix} = \mathbf{y}_e^T \mathbf{F}_e + \mathbf{y}_r^T \mathbf{F}_r \quad (3.292)$$

Introduction of 3.282 into the above equation yields

$$\delta W = (\mathbf{h} \mathbf{y}_r)^T \mathbf{F}_e + \mathbf{y}_r^T \mathbf{F}_r = (\mathbf{y}_r^T \mathbf{h}^T) \mathbf{F}_e + \mathbf{y}_r^T \mathbf{F}_r = \mathbf{y}_r^T (\mathbf{h}^T \mathbf{F}_e + \mathbf{F}_r) \quad (3.293)$$

Hence,

$$\mathbf{F}_c = (\mathbf{h}^T \mathbf{F}_e + \mathbf{F}_r) \quad (3.294)$$

The condensed mathematical model, according to the above consideration, can be adopted as follows

$$\mathbf{m}_c \ddot{\mathbf{y}}_c + \mathbf{c}_c \dot{\mathbf{y}}_c + \mathbf{k}_c \mathbf{y}_c = \mathbf{F}_c \quad (3.295)$$

where

$$\mathbf{y}_c = \mathbf{y}_r \quad (3.296)$$

The relationship 3.282

$$\mathbf{y}_e = \mathbf{h} \mathbf{y}_c$$

permits to produce displacement along the 'cut off' coordinates on the base of solution of the equation 3.295

3.6 PROBLEMS

Problem 52

Produce the natural frequencies and the corresponding natural modes for the fixed-elastically supported uniform beam shown in Fig. 40.

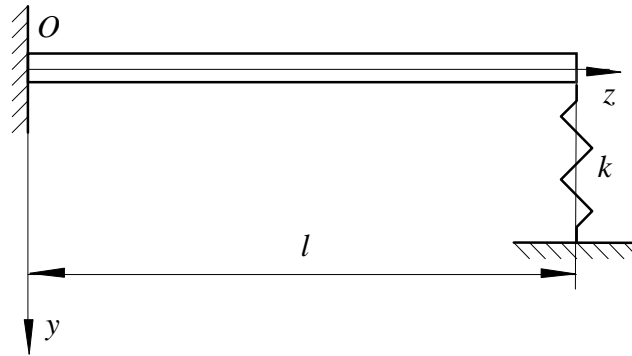

Figure 40

The exact solution of this problem is presented in page 191 for the following data

$$E = 2.1 \times 10^{11} \text{ N/m}^2$$

$$\rho = 7800 \text{ kg/m}^3$$

$$A = 0.03 \times 0.01 = 0.0003 \text{ m}^2$$

$$J = \frac{0.03 \times 0.01^3}{12} = 2.5 \times 10^{-9} \text{ m}^4$$

$$k = 10000 \text{ N/m}$$

$$l = 1 \text{ m}$$

$$\alpha = \frac{EJ}{k} = \frac{2.1 \times 10^{11} \times 2.5 \times 10^{-9}}{10000} = 0.0525$$

Use this data to produce the solution by means of approximation of this beam with 10 finite elements.

Solution

To create the mathematical model of the free-free beam, it was divided into ten finite elements as shown in Fig. 41. The computed mathematical model is

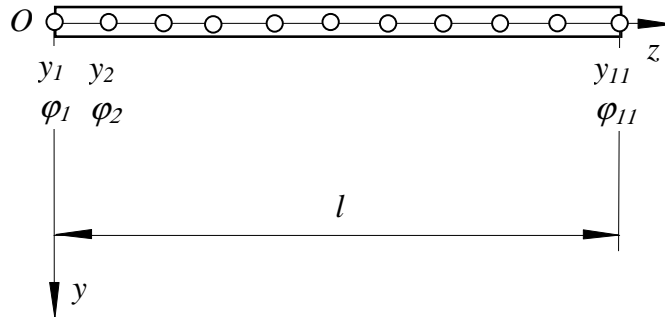

Figure 41

$$m\ddot{\mathbf{y}} + \mathbf{k}\mathbf{y} = \mathbf{0}; \quad \mathbf{y} = \{y_1, \varphi_1, y_2, \varphi_2, \dots, y_{11}, \varphi_{11}\}^T \quad (3.297)$$

The influence of the spring can be represented by the force $-ky_{11}$ acting along the coordinate y_{11} (see Fig. 42).

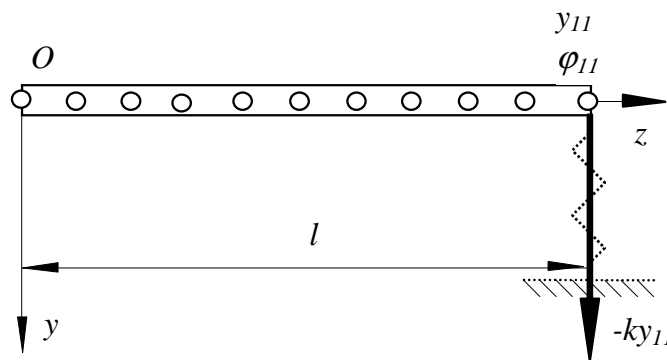

Figure 42

This force should be introduced to the right hand side of the equation 3.297.

$$m\ddot{\mathbf{y}} + \mathbf{k}\mathbf{y} = - \begin{bmatrix} 0 \\ 0 \\ \dots \\ ky_{11} \\ 0 \end{bmatrix} = \begin{bmatrix} 0 & 0 & \dots & \dots & 0 \\ 0 & 0 & \dots & \dots & 0 \\ \dots & \dots & \dots & \dots & \dots \\ 0 & 0 & \dots & k & 0 \\ 0 & 0 & \dots & 0 & 0 \end{bmatrix} \begin{bmatrix} y_1 \\ \varphi_1 \\ \dots \\ y_{11} \\ \varphi_{11} \end{bmatrix} = -\mathbf{k}_1\mathbf{y} \quad (3.298)$$

Therefore, the equation of the beam supported by the spring is

$$m\ddot{\mathbf{y}} + \mathbf{k}_s\mathbf{y} = \mathbf{0} \quad (3.299)$$

where

$$\mathbf{k}_s = \mathbf{k} + \mathbf{k}_1 = \mathbf{k} + \begin{bmatrix} 0 & 0 & \dots & \dots & 0 \\ 0 & 0 & \dots & \dots & 0 \\ \dots & \dots & \dots & \dots & \dots \\ 0 & 0 & \dots & k & 0 \\ 0 & 0 & \dots & 0 & 0 \end{bmatrix} \quad (3.300)$$

To introduce the boundary conditions associated with the left hand side of the beam, let us partition the above mathematical model in such a manner that all the coordinates involved in this boundary conditions are included in the vector \mathbf{y}_1 .

$$\begin{bmatrix} \mathbf{m}_{11} & \mathbf{m}_{12} \\ \mathbf{m}_{21} & \mathbf{m}_{22} \end{bmatrix} \begin{bmatrix} \ddot{\mathbf{y}}_1 \\ \ddot{\mathbf{y}}_2 \end{bmatrix} + \begin{bmatrix} \mathbf{k}_{s11} & \mathbf{k}_{s12} \\ \mathbf{k}_{s21} & \mathbf{k}_{s22} \end{bmatrix} \begin{bmatrix} \mathbf{y}_1 \\ \mathbf{y}_2 \end{bmatrix} = \mathbf{0} \quad (3.301)$$

where

$$\mathbf{y}_1 = \{y_1, \varphi_1\}^T \quad \mathbf{y}_2 = \{y_2, \varphi_2, \dots, y_{11}, \varphi_{11}\}^T \quad (3.302)$$

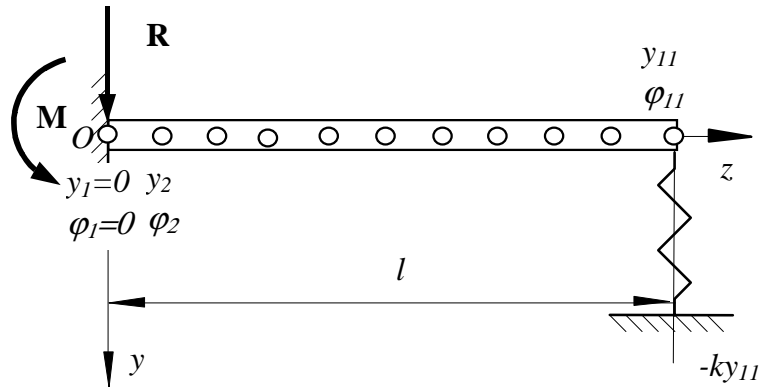

Figure 43

According to the boundary conditions (see Fig. 43)

$$\mathbf{y}_1 = \{y_1, \varphi_1\}^T = \{0, 0\}^T \quad (3.303)$$

and

$$\mathbf{R}_1 = \{R, M\}^T \quad (3.304)$$

Introduction of 3.303 and 3.304 into 3.301 yields

$$\begin{bmatrix} \mathbf{m}_{11} & \mathbf{m}_{12} \\ \mathbf{m}_{21} & \mathbf{m}_{22} \end{bmatrix} \begin{bmatrix} \mathbf{0} \\ \ddot{\mathbf{y}}_2 \end{bmatrix} + \begin{bmatrix} \mathbf{k}_{s11} & \mathbf{k}_{s12} \\ \mathbf{k}_{s21} & \mathbf{k}_{s22} \end{bmatrix} \begin{bmatrix} \mathbf{0} \\ \mathbf{y}_2 \end{bmatrix} = \begin{bmatrix} \mathbf{R}_1 \\ \mathbf{0} \end{bmatrix} \quad (3.305)$$

This equation is equivalent to two equations as follows

$$\mathbf{m}_{12}\ddot{\mathbf{y}}_2 + \mathbf{k}_{s12}\mathbf{y}_2 = \mathbf{R}_1 \quad (3.306)$$

$$\mathbf{m}_{22}\ddot{\mathbf{y}}_2 + \mathbf{k}_{s22}\mathbf{y}_2 = \mathbf{0} \quad (3.307)$$

The second equation 3.307 is the equation of motion of the supported beam. It was solved for the natural modes and the natural frequencies. Results of this computation is shown in Fig. 44 by boxes and in the first column of the Table below. This results are compare with natural modes (continuous line in Fig. 44) and natural frequencies (second column in the Table) obtained by solving the continuous mathematical model (see problem page 190). The equation 3.306 allows the vector of the interation forces \mathbf{R}_1 to be computed.

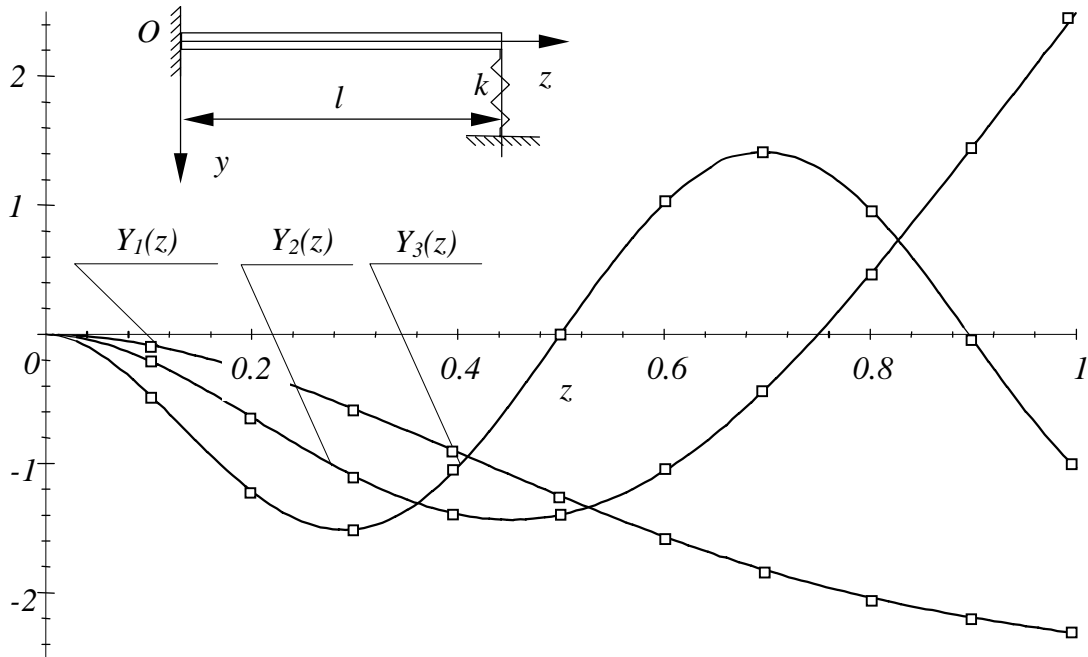

Figure 44

Table

	natural frequencies of the descreet system [1/sec]	natural frequencies of the continuous system [1/sec]
1	129.5	129.65
2	357.6	357.3
3	933.4	932.0

Problem 53

The mathematical model of a free-free beam shown in Fig. 45 along coordinates x_1, x_2, x_3, x_4 is as follows

$$\mathbf{m}\ddot{\mathbf{x}} + \mathbf{k}\mathbf{x} = \mathbf{0} \tag{3.308}$$

$$\mathbf{m} = \begin{bmatrix} m_{11} & m_{12} & m_{13} & m_{14} \\ m_{21} & m_{22} & m_{23} & m_{24} \\ m_{31} & m_{32} & m_{33} & m_{34} \\ m_{41} & m_{42} & m_{43} & m_{44} \end{bmatrix}; \quad \mathbf{k} = \begin{bmatrix} k_{11} & k_{12} & k_{13} & k_{14} \\ k_{21} & k_{22} & k_{23} & k_{24} \\ k_{31} & k_{32} & k_{33} & k_{34} \\ k_{41} & k_{42} & k_{43} & k_{44} \end{bmatrix}; \quad \mathbf{x} = \begin{bmatrix} x_1 \\ x_2 \\ x_3 \\ x_4 \end{bmatrix} \tag{3.309}$$

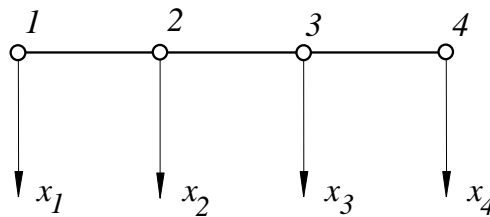

Figure 45

This beam is supported upon three rigid pedestals along coordinates x_1, x_2, x_3 as shown in Fig. 46.

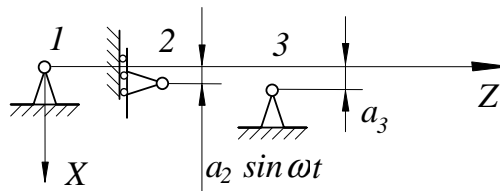

Figure 46

The motion of these supports with respect to the inertial system of coordinate XZ is given by the following equations

$$\begin{aligned} X_1 &= 0 \\ X_2 &= a_2 \sin \omega t \\ X_3 &= a_3 \end{aligned} \tag{3.310}$$

Derive expressions for :

1. the static deflection curve,
2. the interaction forces between the beam and the supports

Solution

Partitioning of the equations 3.308 with respect to the vector of boundary conditions 3.310 results in the following equation

$$\mathbf{m}\ddot{\mathbf{x}} + \mathbf{k}\mathbf{x} = \mathbf{R} \quad (3.311)$$

where

$$\begin{bmatrix} \mathbf{m}_{11} & \mathbf{m}_{12} \\ \mathbf{m}_{21} & \mathbf{m}_{22} \end{bmatrix} \begin{bmatrix} \ddot{\mathbf{x}}_1 \\ \ddot{\mathbf{x}}_2 \end{bmatrix} + \begin{bmatrix} \mathbf{k}_{11} & \mathbf{k}_{12} \\ \mathbf{k}_{21} & \mathbf{k}_{22} \end{bmatrix} \begin{bmatrix} \mathbf{x}_1 \\ \mathbf{x}_2 \end{bmatrix} = \begin{bmatrix} \mathbf{R}_1 \\ \mathbf{R}_2 \end{bmatrix} \quad (3.312)$$

$$\mathbf{m}_{11} = \begin{bmatrix} m_{11} & m_{12} & m_{13} \\ m_{21} & m_{22} & m_{23} \\ m_{31} & m_{32} & m_{33} \end{bmatrix}; \quad \mathbf{m}_{12} = \begin{bmatrix} m_{14} \\ m_{24} \\ m_{34} \end{bmatrix}; \quad \mathbf{m}_{21} = [m_{41} \quad m_{42} \quad m_{43}]; \quad \mathbf{m}_{22} = m_{44} \quad (3.313)$$

$$\mathbf{k}_{11} = \begin{bmatrix} k_{11} & k_{12} & k_{13} \\ k_{21} & k_{22} & k_{23} \\ k_{31} & k_{32} & k_{33} \end{bmatrix}; \quad \mathbf{k}_{12} = \begin{bmatrix} k_{14} \\ k_{24} \\ k_{34} \end{bmatrix}; \quad \mathbf{k}_{21} = [k_{41} \quad k_{42} \quad k_{43}]; \quad \mathbf{k}_{22} = k_{44} \quad (3.314)$$

$$\mathbf{x}_1 = \begin{bmatrix} x_1 \\ x_2 \\ x_3 \end{bmatrix}; \quad \mathbf{x}_2 = x_4; \quad \mathbf{R}_1 = \begin{bmatrix} R_1 \\ R_2 \\ R_3 \end{bmatrix}; \quad \mathbf{R}_2 = 0 \quad (3.315)$$

or

$$\mathbf{m}_{11}\ddot{\mathbf{x}}_1 + \mathbf{m}_{12}\ddot{\mathbf{x}}_2 + \mathbf{k}_{11}\mathbf{x}_1 + \mathbf{k}_{12}\mathbf{x}_2 = \mathbf{R}_1 \quad (3.316)$$

$$\mathbf{m}_{21}\ddot{\mathbf{x}}_1 + \mathbf{m}_{22}\ddot{\mathbf{x}}_2 + \mathbf{k}_{21}\mathbf{x}_1 + \mathbf{k}_{22}\mathbf{x}_2 = \mathbf{0} \quad (3.317)$$

Introduction of boundary conditions 3.310 into the equation 3.317 yields

$$m_{44}\ddot{x}_4 + k_{44}x_4 = - [m_{41} \quad m_{42} \quad m_{43}] \begin{bmatrix} \ddot{x}_1 \\ \ddot{x}_2 \\ \ddot{x}_3 \end{bmatrix} - [k_{41} \quad k_{42} \quad k_{43}] \begin{bmatrix} x_1 \\ x_2 \\ x_3 \end{bmatrix} \quad (3.318)$$

where

$$\begin{bmatrix} \ddot{x}_1 \\ \ddot{x}_2 \\ \ddot{x}_3 \end{bmatrix} = \begin{bmatrix} 0 \\ -a_2\omega^2 \sin \omega t \\ 0 \end{bmatrix}; \quad \begin{bmatrix} x_1 \\ x_2 \\ x_3 \end{bmatrix} = \begin{bmatrix} 0 \\ a_2 \sin \omega t \\ a_3 \end{bmatrix} \quad (3.319)$$

or

$$m_{44}\ddot{x}_4 + k_{44}x_4 = (m_{42}a_2\omega^2 - k_{42}a_2) \sin \omega t - k_{43}a_3 \quad (3.320)$$

The static deflection is due to the time independent term $-k_{43}a_3$ in the right hand side of the equation 3.320.

$$m_{44}\ddot{x}_4 + k_{44}x_4 = -k_{43}a_3 \quad (3.321)$$

The particular solution of the equation 3.321 is

$$x_4 = x_s \quad (3.322)$$

$$k_{44}x_s = -k_{43}a_3 \quad (3.323)$$

$$x_s = \frac{-k_{43}a_3}{k_{44}} \tag{3.324}$$

Its graphical representation is given in Fig. 47

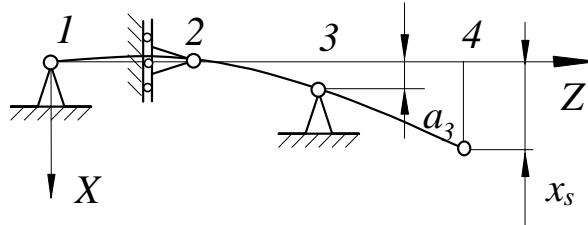

Figure 47

The forced response due to motion of the support 2 ($X_2 = a_2 \sin \omega t$) is represented by the particular solution due to the time dependant term.

$$m_{44}\ddot{x}_4 + k_{44}x_4 = (m_{42}a_2\omega^2 - k_{42}a_2) \sin \omega t \tag{3.325}$$

For the above equation, the particular solution may be predicted as follows

$$x_4 = x_d \sin \omega t \tag{3.326}$$

Implementation of the solution 3.326 into the equation 3.325 yields the wanted amplitude of the forced vibration x_d .

$$x_d = \frac{(m_{42}a_2\omega^2 - k_{42}a_2)}{-\omega^2m_{44} + k_{44}} \tag{3.327}$$

The resultant motion of the system considered is shown in Fig. 48

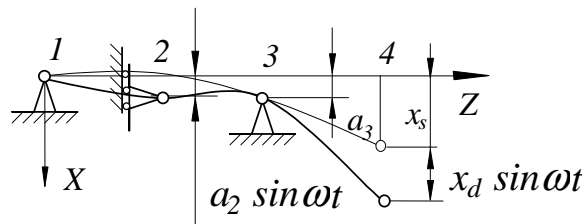

Figure 48

This motion causes interaction forces along these coordinates along which the system is attached to the base. These forces can computed from equation 3.316.

$$\mathbf{m}_{11}\ddot{\mathbf{x}}_1 + \mathbf{m}_{12}\ddot{\mathbf{x}}_2 + \mathbf{k}_{11}\mathbf{x}_1 + \mathbf{k}_{12}\mathbf{x}_2 = \mathbf{R}_1 \tag{3.328}$$

In this equation \mathbf{x}_1 stands for the given boundary conditions

$$\mathbf{x}_1 = \begin{bmatrix} x_1 \\ x_2 \\ x_3 \end{bmatrix} = \begin{bmatrix} 0 \\ a_2 \sin \omega t \\ a_3 \end{bmatrix} ; \ddot{\mathbf{x}}_1 = \begin{bmatrix} \ddot{x}_1 \\ \ddot{x}_2 \\ \ddot{x}_3 \end{bmatrix} = \begin{bmatrix} 0 \\ -a_2\omega^2 \sin \omega t \\ 0 \end{bmatrix} \tag{3.329}$$

and \mathbf{x}_2 represents, known at this stage, motion of the system along the coordinate 4

$$\mathbf{x}_2 = x_4 = x_s + x_d \sin \omega t \quad \ddot{\mathbf{x}}_2 = \ddot{x}_4 = \frac{d^2}{dt^2}(x_s + x_d \sin \omega t) = -x_d \omega^2 \sin \omega t; \quad (3.330)$$

Hence, the wanted vector of interaction forces is as follows

$$\mathbf{R}_1 = \mathbf{m}_{11} \begin{bmatrix} 0 \\ -a_2 \omega^2 \sin \omega t \\ 0 \end{bmatrix} + \mathbf{k}_{11} \begin{bmatrix} 0 \\ a_2 \sin \omega t \\ a_3 \end{bmatrix} + \mathbf{m}_{12}(-x_d \omega^2 \sin \omega t) + \mathbf{k}_{12}(x_s + x_d \sin \omega t) \quad (3.331)$$

Part II

EXPERIMENTAL INVESTIGATION

Chapter 4
MODAL ANALYSIS OF A SYSTEM WITH 3 DEGREES OF
FREEDOM

4.1 DESCRIPTION OF THE LABORATORY INSTALLATION

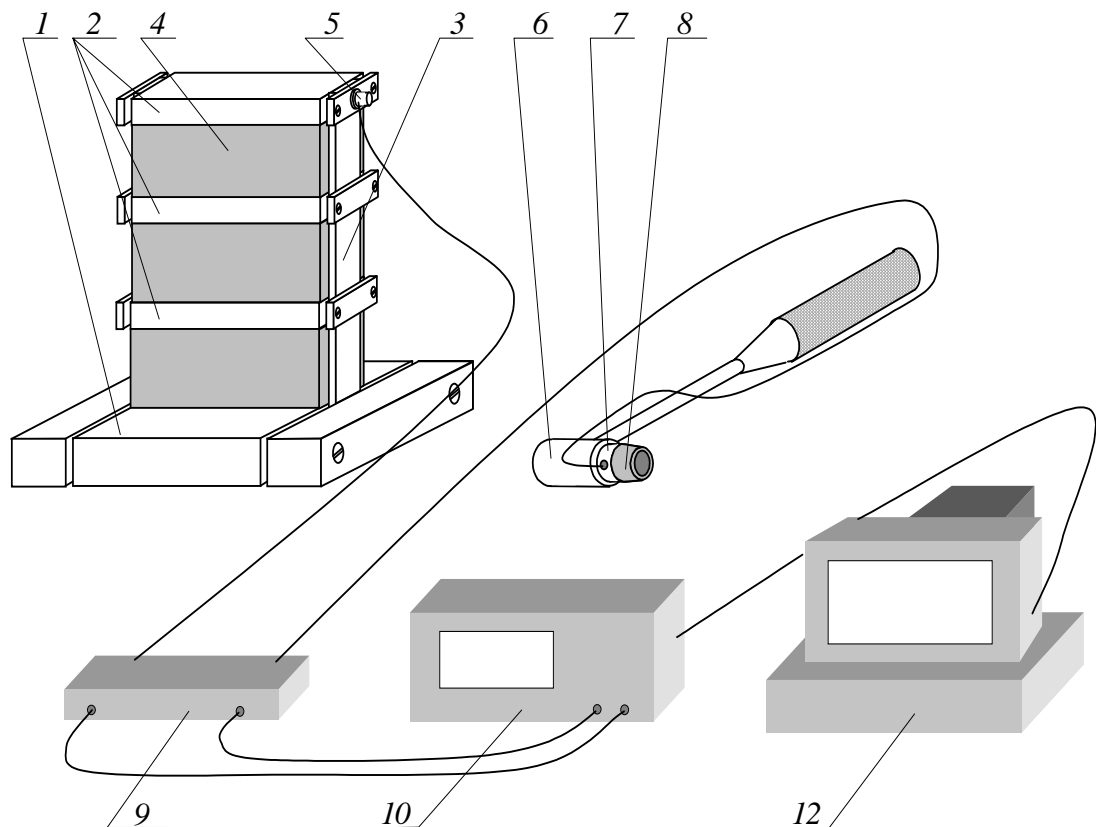

Figure 1

The vibrating object 2, 3, and 4 (see Fig.1) is attached to the base 1. It consists of the three rectangular blocks 2 joint together by means of the two springs 3. The spaces between the blocks 2 are filled in with the foam 4 in order to increase the structural damping. The transducer 5 allows the acceleration of the highest block to be measured in the horizontal direction. The hammer 6 is used to induce vibrations of the object. It is furnished with the piezoelectric transducer 7 that permits the impulse of the force applied to the object to be measured. The rubber tip 8 is used

to smooth and extend the impulse of force. Both, the acceleration of the object and the impulse of the force can be simultaneously recorded and stored in the memory of the spectrum analyzer 10. These data allow the transfer functions to be produced and sent to the personal computer 11 for further analysis.

4.2 MODELLING OF THE OBJECT

4.2.1 Physical model

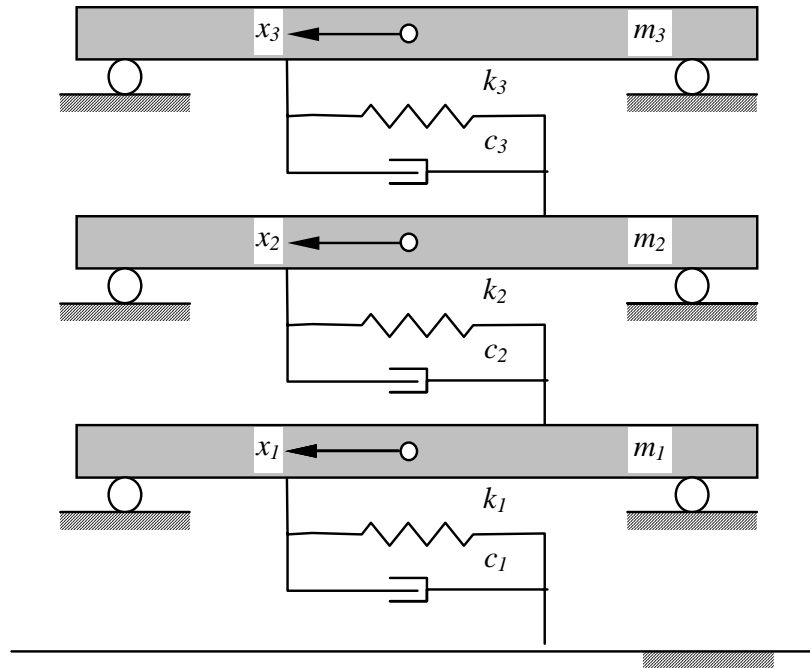

Figure 2

The base 1, which is considered rigid and motionless, forms a reference system for measuring its vibrations. The blocks 2 are assumed to be rigid and the springs 3 are by assumption massless. Motion of the blocks is restricted to one horizontal direction only. Hence, according to these assumptions, the system can be approximated by three degrees of freedom physical model. The three independent coordinates x_1 , x_2 and x_3 are shown in Fig.2. Magnitudes of the stiffness k_1 , k_2 and k_3 of the springs can be analytically assessed. To this end let us consider one spring shown in Fig. 3 The differential equation of the deflection of the spring is

$$EJ \frac{d^2x}{dz^2} = M - Fz = \frac{FH}{2} - Fz \tag{4.1}$$

Double integration results in the following equation of the bending line.

$$EJ \frac{dx}{dz} = \frac{FH}{2}z - \frac{F}{2}z^2 + A \tag{4.2}$$

$$EJx = \frac{FH}{4}z^2 - \frac{F}{6}z^3 + Az + B \tag{4.3}$$

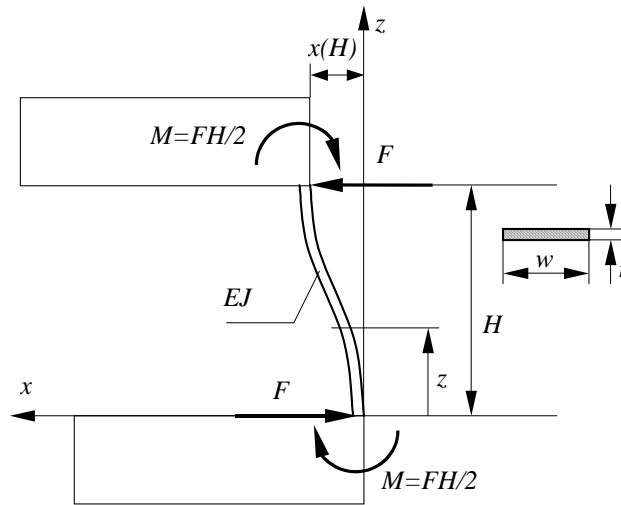

Figure 3

Taking advantage of the boundary conditions associated with the lower end of the spring, one can arrived to the following expression for the bending line.

$$x = \frac{1}{EJ} \left(\frac{FH}{4} z^2 - \frac{F}{6} z^3 \right) \tag{4.4}$$

Hence, the deflection of the upper end is

$$x(H) = \frac{1}{EJ} \left(\frac{FH}{4} H^2 - \frac{F}{6} H^3 \right) = \frac{1}{12EJ} FH^3 \tag{4.5}$$

Therefore the stiffness of one spring is

$$k = \frac{F}{x(H)} = \frac{12EJ}{H^3} \tag{4.6}$$

where

$$J = \frac{wt^3}{12} \tag{4.7}$$

Since we deal with a set of two springs between the blocks, the stiffness k_i shown in the physical model can be computed according to the following formula.

$$k_i = \frac{24E_i J_i}{H_i^3} \tag{4.8}$$

4.2.2 Mathematical model

Application of the Newton's equations to the developed physical model results in the following set of differential equations

$$\begin{aligned} m_1 \ddot{x}_1 + (c_1 + c_2) \dot{x}_1 + (-c_2) \dot{x}_2 + (k_1 + k_2) x_1 + (-k_2) x_2 &= F_1 \\ m_2 \ddot{x}_2 + (-c_2) \dot{x}_1 + (c_2 + c_3) \dot{x}_2 + (-c_3) \dot{x}_3 + (-k_2) x_1 + (k_2 + k_3) x_2 + (-k_3) x_3 &= F_2 \\ m_3 \ddot{x}_3 + (-c_3) \dot{x}_2 + c_3 \dot{x}_3 + (-k_3) x_2 + k_3 x_3 &= F_3 \end{aligned}$$

These equations can be rewritten as following

$$\mathbf{m}\ddot{\mathbf{x}} + \mathbf{c}\dot{\mathbf{x}} + \mathbf{k}\mathbf{x} = \mathbf{F} \quad (4.9)$$

where

$$\mathbf{m} = \begin{bmatrix} m_1 & 0 & 0 \\ 0 & m_2 & 0 \\ 0 & 0 & m_3 \end{bmatrix}; \quad \mathbf{c} = \begin{bmatrix} c_1 + c_2 & -c_2 & 0 \\ -c_2 & c_2 + c_3 & -c_3 \\ 0 & -c_3 & c_3 \end{bmatrix}$$

$$\mathbf{k} = \begin{bmatrix} k_1 + k_2 & -k_2 & 0 \\ -k_2 & k_2 + k_3 & -k_3 \\ 0 & -k_3 & k_3 \end{bmatrix}; \quad \mathbf{x} = \begin{bmatrix} x_1 \\ x_2 \\ x_3 \end{bmatrix}; \quad \mathbf{F} = \begin{bmatrix} F_1 \\ F_2 \\ F_3 \end{bmatrix} \quad (4.10)$$

The vector \mathbf{F} represents the external excitation that can be applied to the system.

4.3 ANALYSIS OF THE MATHEMATICAL MODEL

4.3.1 Natural frequencies and natural modes of the undamped system.

The matrix of inertia and the matrix of stiffness can be assessed from the dimensions of the object. Hence, the natural frequencies and the corresponding natural modes of the undamped system can be produced. Implementation of the particular solution

$$\mathbf{x} = \mathbf{X} \cos \omega t \quad (4.11)$$

into the equation of the free motion of the undamped system

$$\mathbf{m}\ddot{\mathbf{x}} + \mathbf{k}\mathbf{x} = \mathbf{F} \quad (4.12)$$

results in a set of the algebraic equations that are linear with respect to the vector \mathbf{X} .

$$(-\omega^2 \mathbf{m} + \mathbf{k}) \mathbf{X} = \mathbf{0} \quad (4.13)$$

Solution of the eigenvalue and eigenvector problem yields the natural frequencies and the corresponding natural modes.

$$\pm\omega_1, \quad \pm\omega_2, \quad \pm\omega_3 \quad (4.14)$$

$$\mathbf{\Xi} = [\mathbf{\Xi}_1, \mathbf{\Xi}_2, \mathbf{\Xi}_3] \quad (4.15)$$

For detailed explanation see pages 102 to 105

4.3.2 Equations of motion in terms of the normal coordinates - transfer functions

If one assume that the damping matrix is of the following form

$$\mathbf{c} = \mu \mathbf{m} + \kappa \mathbf{k} \quad (4.16)$$

the equations of motion 4.9 can be expressed in terms of the normal coordinates $\boldsymbol{\eta} = \mathbf{\Xi}^{-1} \mathbf{x}$ (see section *normal coordinates - modal damping* page 105)

$$\ddot{\eta}_n + 2\xi_n \omega_n \dot{\eta}_n + \omega_n^2 \eta_n = \mathbf{\Xi}_n^T \mathbf{F}(t), \quad n = 1, 2, 3 \quad (4.17)$$

The response of the system along the coordinate x_p due to the harmonic excitation $F_q e^{i\omega t}$ along the coordinate x_q , according to the formula 2.142 (page 107), is

$$x_p = e^{i\omega t} \sum_{n=1}^N \frac{\Xi_{pn} \Xi_{qn} F_q}{\omega_n^2 - \omega^2 + 2\zeta_n \omega_n \omega i} \quad (4.18)$$

Hence the acceleration along the coordinate x_p as the second derivative with respect to time, is

$$\ddot{x}_p = -\omega^2 e^{i\omega t} \sum_{n=1}^N \frac{\Xi_{pn} \Xi_{qn} F_q}{\omega_n^2 - \omega^2 + 2\zeta_n \omega_n \omega i} \quad (4.19)$$

It follows that the transfer function between the coordinate x_p and x_q , according to 2.144 is

$$\begin{aligned} R_{pq}(i\omega) &= \frac{\ddot{x}_p}{F_q e^{i\omega t}} = -\omega^2 \frac{x_p}{F_q e^{i\omega t}} = \\ &= -\omega^2 \sum_{n=1}^N \left(\frac{\Xi_{pn} \Xi_{qn} (\omega_n^2 - \omega^2)}{(\omega_n^2 - \omega^2)^2 + 4\zeta_n^2 \omega_n^2 \omega^2} + \frac{-2\Xi_{pn} \Xi_{qn} \zeta_n \omega_n \omega i}{(\omega_n^2 - \omega^2)^2 + 4\zeta_n^2 \omega_n^2 \omega^2} \right) \quad q = 1, 2, 3 \end{aligned} \quad (4.20)$$

The modal damping ratios ζ_1 , ζ_2 and ζ_3 are unknown and are to be identified by fitting the analytical transfer functions into the experimental ones. Since the transducer 5 (Fig. 1) produces acceleration, the laboratory installation permits to obtain the acceleration to force transfer function. The theory on the experimental determination of the transfer functions is given in the section *Experimental determination of the transfer functions* (page 100).

4.3.3 *Extraction of the natural frequencies and the natural modes from the transfer functions*

The problem of determination of the natural frequencies and the natural modes from the **displacement - force** transfer functions was explained in details in section *Determination of natural frequencies and modes from the transfer functions* (page 107). Let us do similar manipulation on the **acceleration - force** transfer function. First of all let us notice that

$$if \quad \omega \cong \omega_n \quad R_{pq}(i\omega_n) \cong -\omega^2 \left(\frac{\Xi_{pn} \Xi_{qn} (\omega_n^2 - \omega^2)}{4\zeta_n^2 \omega_n^2 \omega^2} + \frac{-\Xi_{pn} \Xi_{qn} i}{2\zeta_n \omega_n \omega} \right) \quad q = 1, 2, 3 \quad (4.21)$$

Since the real part of the transfer function is equal to zero for $\omega = \omega_n$, its absolute value is equal to the absolute value of the imaginary part.

$$|R_{pq}(i\omega_n)| \cong \left| \frac{\Xi_{pn} \Xi_{qn}}{2\zeta_n} \right| \quad q = 1, 2, 3 \quad (4.22)$$

and phase φ for $\omega = \omega_n$

$$\varphi = \arctan \frac{\text{Im}(R_{pq}(i\omega_n))}{\text{Re}(R_{pq}(i\omega_n))} = \arctan \infty = \pm 90^\circ \quad (4.23)$$

Hence, the frequencies ω corresponding to the phase $\pm 90^\circ$ are the wanted natural frequencies ω_n .

Because ς_n and Ξ_{pn} are constants, magnitudes of the absolute value of the transfer functions for $\omega = \omega_n$ represents the modes $\Xi_{1n}, \Xi_{2n}, \Xi_{3n}$ associated with the n -th natural frequency. An example of extracting the natural frequency and the corresponding natural mode from the transfer function is shown in Fig. 4

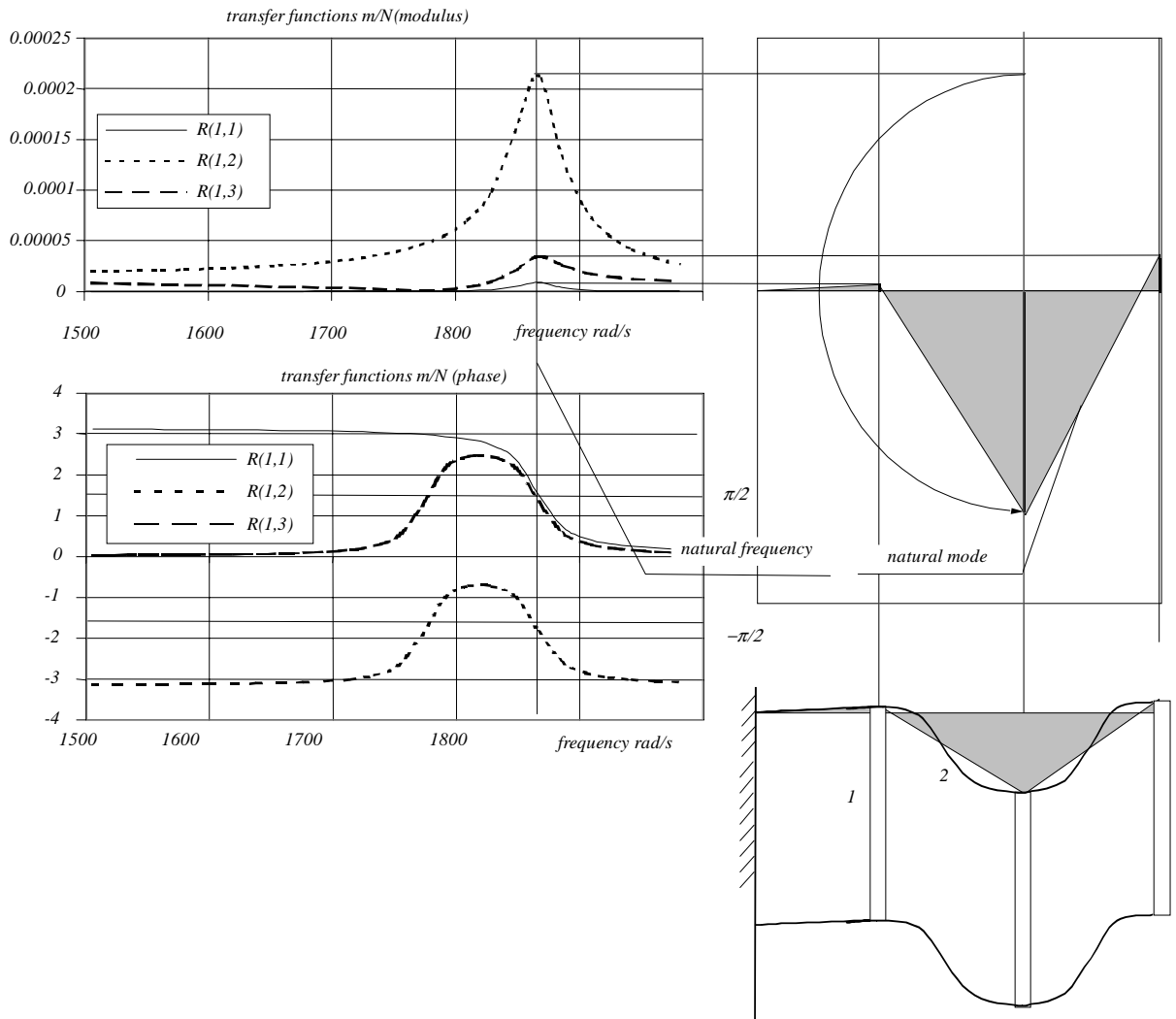

Figure 4

4.4 EXPERIMENTAL INVESTIGATION

4.4.1 Acquiring of the physical model initial parameters

The physical model is determined by the following parameters

m_1, m_2, m_3 - masses of the blocks

k_1, k_2, k_3 - stiffness of the springs

c_1, c_2, c_3 - damping coefficients

The blocks were weighted before assembly and their masses are

$$m_1 = 0.670kg$$

$$m_2 = 0.595kg$$

$$m_3 = 0.595kg$$

The formula 4.7 and 4.8

$$k_i = \frac{24EJ}{H_i^3}; \quad J = \frac{wt^3}{12} \tag{4.24}$$

allows the stiffness k_i to be computed.

The following set of data is required

$$E = 0.21 \times 10^{12}N/m^2$$

$w = \dots\dots\dots m$ to be measured during the laboratory session

$t = \dots\dots\dots m$ to be measured during the laboratory session

$H_1 = \dots\dots\dots m$ to be measured during the laboratory session

$H_2 = \dots\dots\dots m$ to be measured during the laboratory session

$H_3 = \dots\dots\dots m$ to be measured during the laboratory session

The damping coefficients c_i are difficult to be assessed. Alternatively the damping properties of the system can be uniquely defined by means of the three modal damping ratios ς_1, ς_2 and ς_3 (see equation 4.17). $\xi = 1$ corresponds to the critical damping. Inspection of the free vibrations of the object lead to the conclusion that the damping is much smaller then the critical one. Hence, as the first approximation of the damping, let us adopt the following damping ratios

$$\varsigma_1 = 0.01$$

$$\varsigma_2 = 0.01$$

$$\varsigma_3 = 0.01$$

4.4.2 Measurements of the transfer functions

According to the description given in section *Experimental determination of the transfer functions* (page 100) to produce the transfer function $R_{pq}(i\omega)$ you have to measure response of the system along the coordinate x_p due to impulse along the coordinate x_q . Since the transducer 5 (Fig. 1) is permanently attached to the mass m_3 and the impulse can be applied along the coordinates x_1, x_2 or x_3 , the laboratory installation permits the following transfer functions to be obtained.

$$R_{31}(i\omega) \quad R_{32}(i\omega) \quad R_{33}(i\omega) \tag{4.25}$$

The hammer 6 should be used to introduce the impulse. To obtain a reliable result, 10 measurements are to be averaged to get one transfer function. These impulses should be applied to the middle of the block. The spectrum analyzer must show the 'waiting for trigger' sign before the subsequent impulse is applied.

As the equipment used is delicate and expensive, one has to observe the following;

1. always place the hammer on the pad provided when it is not used
2. when applying the impulse to the object make sure that the impulse is not excessive

Harder impact does not produce better results.

4.4.3 Identification of the physical model parameters

In a general case, the identification of a physical model parameters from the transfer functions bases on a very complicated curve fitting procedures. In this experiment, to fit the analytical transfer functions into the experimental one, we are going to use the *trial and error* method. We assume that the following parameters

$$m_1, m_2, m_3, H_1, H_2, H_3, w, E \quad (4.26)$$

were assessed with a sufficient accuracy. Uncertain are

$$t, \xi_1, \xi_2, \xi_3 \quad (4.27)$$

Use the parameter t to shift the natural frequencies (increment of t results in shift of the natural frequencies to the right). Use the parameters ξ_i to align the picks of the absolute values of the transfer functions (increment in the modal damping ratio results in lowering the pick of the analytical transfer function). Work on one (say $R_{33}(i\omega)$) transfer function only.

4.5 WORKSHEET

1. Initial parameters of physical model

Measure the missing parameters and insert them to the table below

$m_1 = 0.670kg$	Mass of the block 1	$H_1 = \dots\dots\dots m$	length of the spring 1
$m_2 = 0.595kg$	Mass of the block 2	$H_2 = \dots\dots\dots m$	length of the spring 2
$m_1 = 0.595kg$	Mass of the block 3	$H_3 = \dots\dots\dots m$	length of the spring 3
$\xi_1 = 0.01$	damping ratio of mode 1	$E = 0.21 \times 10^{12} N/m^2$	Young's modulus
$\xi_2 = 0.01$	damping ratio of mode 2	$w = \dots\dots\dots m$	width of the springs
$\xi_3 = 0.01$	damping ratio of mode 3	$t = \dots\dots\dots m$	thickness of the springs

Run program 'Prac3'* and choose menu 'Input data' to enter the above data.
Set excitation coordinate **3**, response coordinate **3**.

Save the initial data.

2. Experimental acceleration-force transfer functions $R_{33}(i\omega)$

Choose menu 'Frequency response measurements'

Set up the spectrum analyzer by execution of the sub-menu 'Setup analyzer'

Choose sub-menu 'Perform measurement', execute it and apply 10 times impulse along the coordinates 3

Choose sub-menu 'Time/Frequency domain toggle' to see the measured transfer function

Choose sub-menu 'Transfer TRF to computer' and execute it

Exit menu 'Frequency response measurements'

Choose 'Response display/plot' to display the transfer functions

3. Identification of the thickness t and the modal damping ratios ξ_i

You can see both the experimental and analytical transfer function $R_{33}(i\omega)$. By varying t , ξ_1 , ξ_2 , ξ_3 in the input data, try to fit the analytical data into the experimental one. Use the parameter t to shift the natural frequencies (increment of t results in shift of the natural frequencies to the right). Use the parameters ξ_i to align the picks of the absolute values of the transfer functions (increment in the modal damping ratio results in lowering the pick of the analytical transfer function).

*program designed by Dr. T. Chalko

Record the identified parameters in the following table

$m_1 = 0.670kg$	Mass of the block 1	$H_1 = \dots\dots\dots m$	length of the spring 1
$m_2 = 0.595kg$	Mass of the block 2	$H_2 = \dots\dots\dots m$	length of the spring 2
$m_1 = 0.595kg$	Mass of the block 3	$H_3 = \dots\dots\dots m$	length of the spring 3
$\xi_1 = 0.01$	damping ratio of mode 1	$E = 0.21 \times 10^{12} N/m^2$	Young's modulus
$\xi_2 = 0.01$	damping ratio of mode 2	$w = \dots\dots\dots m$	width of the springs
$\xi_3 = 0.01$	damping ratio of mode 3	$t = \dots\dots\dots m$	thickness of the springs

Save the identified parameters.

Plot the analytical and the experimental transfer function $R_{33}(i\omega)$

4. Experimental and analytical transfer functions $R_{31}(i\omega)$ and $R_{32}(i\omega)$

Choose menu 'Input data' and set the excitation coordinate to 1 and the response coordinate to 3

Repeat all steps of the section 2

Plot the transfer function $R_{31}(i\omega)$

Choose menu 'Input data' and set the excitation coordinate to 2 and the response coordinate to 3

Repeat all steps of the section 2

Plot the transfer function $R_{32}(i\omega)$

5. Natural frequencies and the corresponding natural modes

Choose menu 'Mode shapes display/plot' to produce the analytical frequencies and modes

Plot the natural modes

From plots of the experimental transfer functions $R_{31}(i\omega)$, $R_{32}(i\omega)$, $R_{33}(i\omega)$ determine the natural frequencies and the natural modes

Insert the experimental and analytical frequencies into the table below

	natural frequency 1	natural frequency 2	natural frequency 3
analytical
experimental

6. Conclusions